

sesino

HEAT EXCHANGING EXCELLENCE SINCE 1919



GENERAL CATALOGUE
CATALOGO GENERALE

Sesino S.p.A. owns all the graphic elements of the present catalogue: the company's logo, the brand, the article's code, the drawings, and the graphic project of the catalogue. We reserve the right to act against any improper or unauthorized use. Our technical data, our descriptions and drawings are reproduced with the utmost care, we reserve nevertheless the right to make changes as appropriate.

La Sesino SpA detiene l'assoluta proprietà degli elementi grafici del presente catalogo, vale a dire: il logotipo aziendale, il marchio, il codice degli articoli, i disegni, il progetto grafico del catalogo, e si riserva la facoltà di difendere a termini di legge ogni illecito uso, non espressamente autorizzato. I nostri dati tecnici, le nostre descrizioni e i disegni sono riportati con la massima accuratezza possibile, ma devono intendersi orientativi e ci riserviamo la facoltà di apportare varianti in qualunque momento.

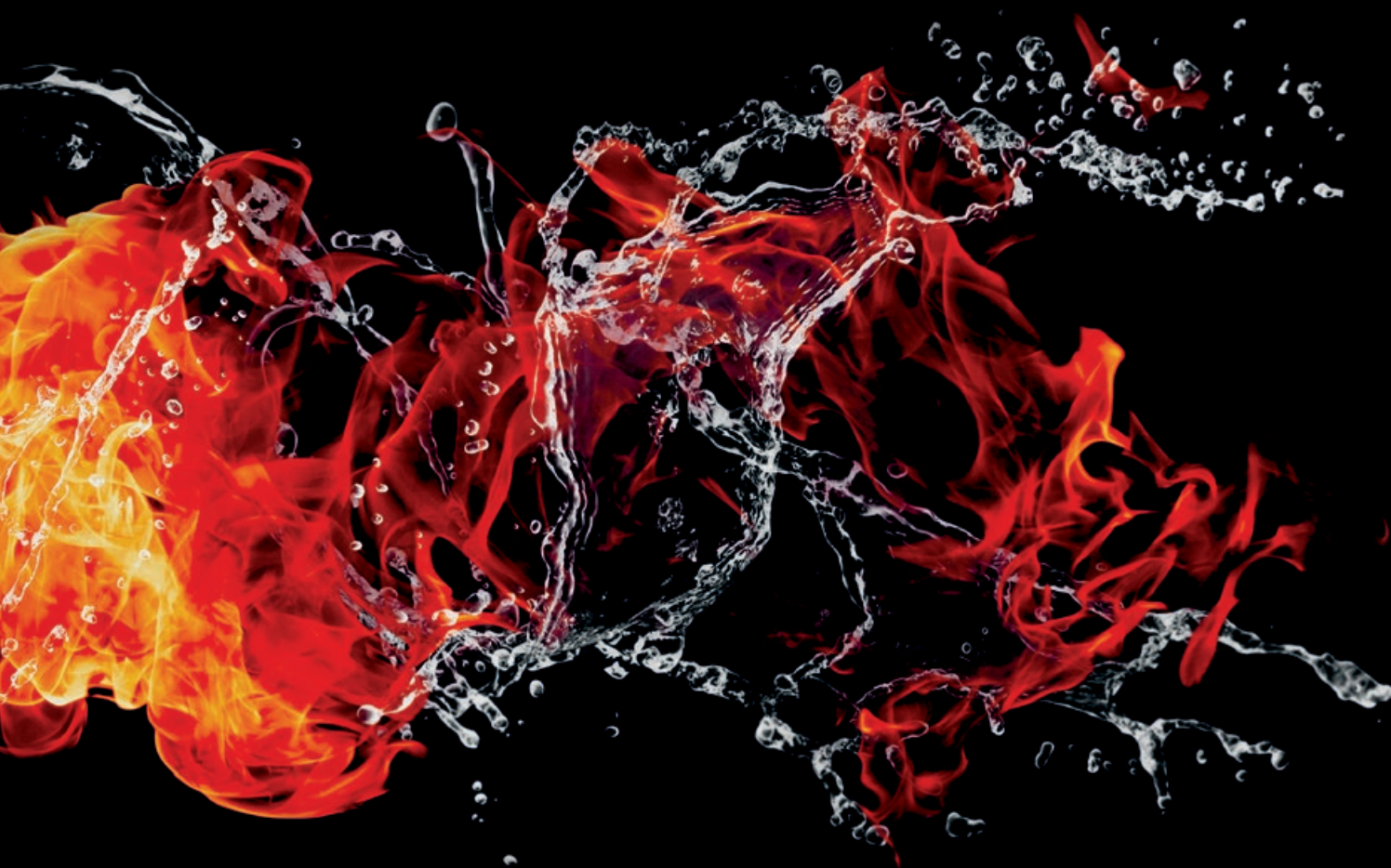

Edition 2025

Art direction: Imagines agentes

© Costante Sesino S.p.A. - All rights reserved



HEAT EXCHANGING EXCELLENCE SINCE 1919

GENERAL CATALOGUE
CATALOGO GENERALE

2025

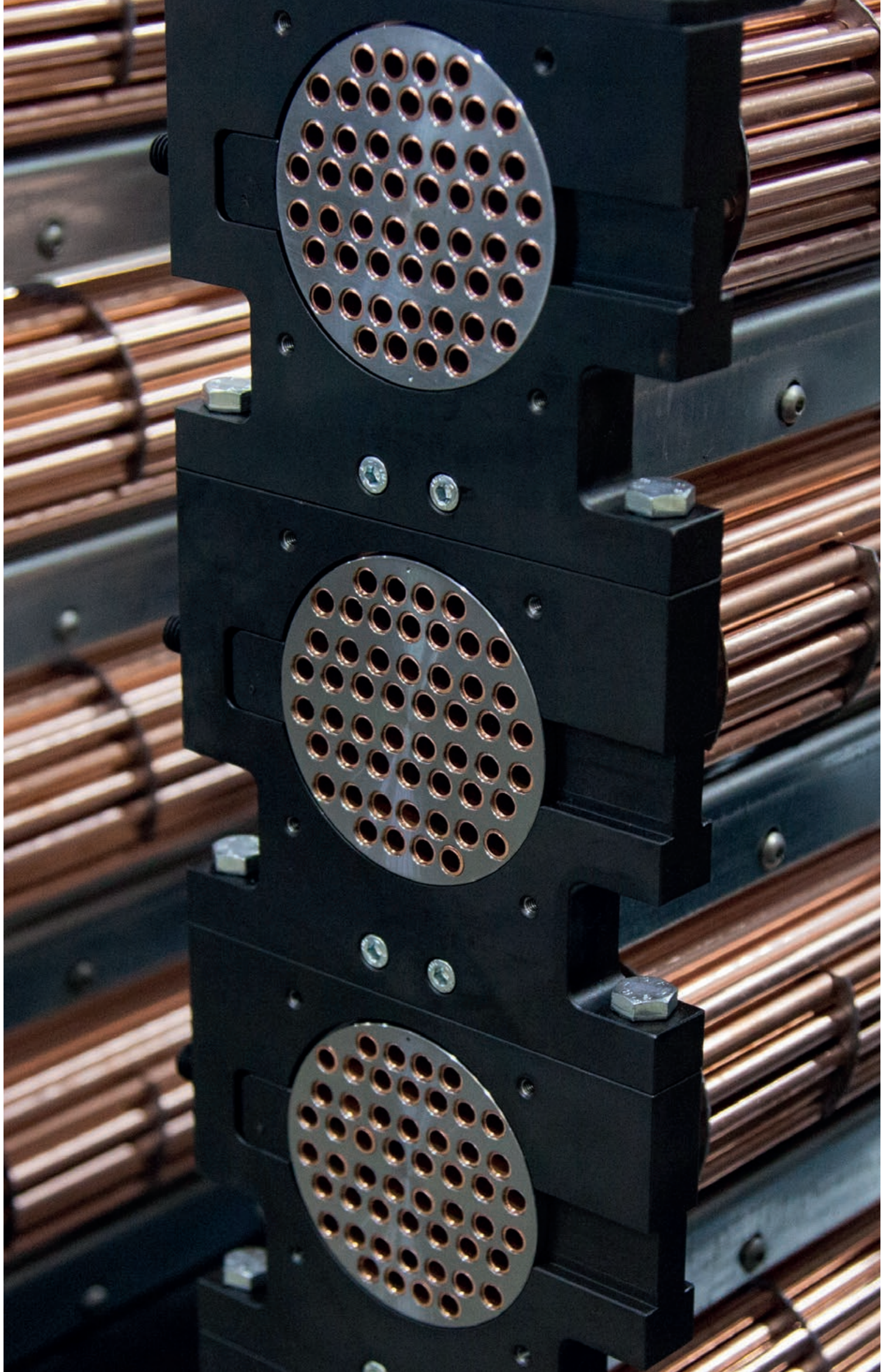

OUR PHILOSOPHY *FILOSOFIA AZIENDALE*

SESINO philosophy has its grounding on the following principles.

1. **FULL QUALITY**, meant to be product's quality, assistance and organization quality, quality of our raw materials and our measuring and checking instruments, everything according to ISO 9001:2008 Regulation.
2. **OCCUPATIONAL SAFETY**, a commitment to our staff, in order to grant them no risks while working. A policy for which we obtained BS OHSAS 18001:2007 Certification.
3. **PROACTIVE SKILLS**, Sesino aptitude to support and cooperate with customer in order to optimize the development of their projects. SESINO can offer custom-made products, produced according to our client's needs, using our experience, knowledge, human resources and technology.
4. **COMPETITIVENESS**, which means to be able to face our competitors and believe that we can succeed. This features is the result of corporate growth, increase in the sales volume, expense reduction and the possibility to invest in technology and marketing research.

La filosofia aziendale della SESINO pone le sue basi sui seguenti fondamenti.

1. **QUALITÀ TOTALE**, *intesa come qualità del prodotto, qualità del servizio, qualità dell'organizzazione, qualità degli strumenti di controllo, qualità delle materie prime, ma non solo a parole, bensì certificata secondo le norme ISO 9001:2008.*
2. **SICUREZZA SUL LAVORO**, *un impegno che ci siamo assunti nei confronti di tutti i nostri collaboratori perché possano lavorare senza rischi di incidenti, anche qui, non solo a parole, bensì certificata secondo la Norma BS OHSAS 18001:2007*
3. **CAPACITÀ PROPOSITIVA**, *intesa come un preciso impegno della SESINO a essere vicina in modo particolare ai costruttori allo scopo di collaborare con gli stessi per l'ottimizzazione e lo sviluppo dei loro progetti. È inoltre una caratteristica produttiva della SESINO quella di poter offrire prodotti fuori standard, costruiti in funzione delle specifiche esigenze della clientela; questo naturalmente presuppone conoscenza, esperienza, risorse umane e tecnologiche per affrontare e risolvere i problemi.*
4. **COMPETITIVITÀ**, *che significa doversi e potersi misurare con tutti gli antagonisti, con la consapevolezza di poter anche essere vincenti. La competitività è senza dubbio il risultato di diversi componenti quali la crescita aziendale, l'incremento del fatturato, il contenimento delle spese, la possibilità di finanziare investimenti tecnologici per la ricerca, per il marketing e così via.*



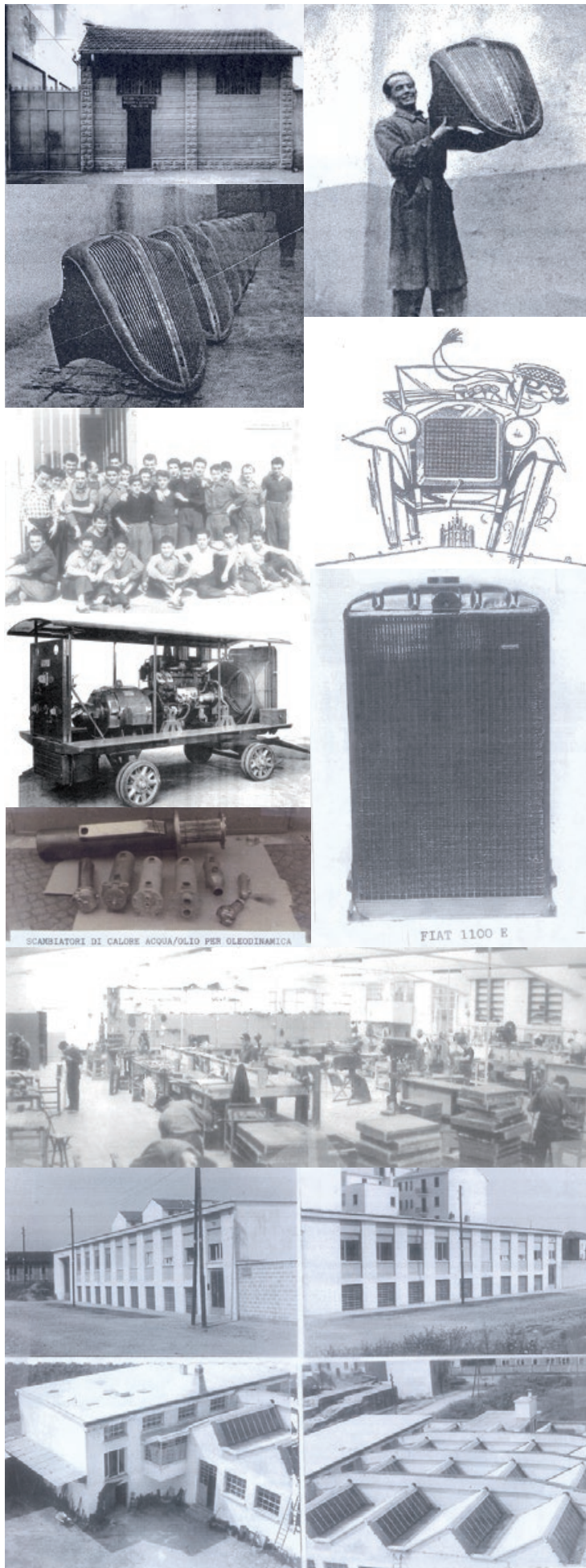

1919

The Sesino brothers founded the company F.lli Sesino & C., having as its main activity the production and maintenance of grills and radiators for vehicles. *I fratelli Sesino costituiscono la F.lli Sesino & C., avente come attività la costruzione e riparazione di mascherine e radiatori per automobili.*

1920

F.lli Sesino & C. took part into the first Exhibition in Milan and got several statements and rewards for its activity. *La F.lli Sesino & C. partecipa alla prima FIERA DI MILANO e ottiene attestazioni e riconoscimenti per l'attività svolta.*

1922

F.lli Sesino & C., after having received a big order for the production of car radiators from company Edoardo Bianchi, moved from the old workshop to the new place in Via Noè, Milan. Until the II World War, the company got several orders for grills and radiators from Bianchi and FIAT. Then, in the new site began the production of gas and electric unit heaters, condensers and evaporators for the first refrigerating systems. *La F.lli Sesino & C., acquisita una fornitura di radiatori per la casa automobilistica EDOARDO BIANCHI, si trasferisce dalla bottega artigiana degli esordi in una nuova sede in Via Noè a Milano. Fino allo scoppio della seconda guerra mondiale, vengono acquisiti ordini per forniture di mascherine e radiatori, oltre che dalla EDOARDO BIANCHI, dalla FIAT. In questa nuova sede inizia la produzione di aerotermi a gas ed elettrici, condensatori ed evaporatori per i primi impianti frigoriferi.*

1934

With the resignation of brother Alfredo the company became Costante Sesino & C. *Con le dimissioni del fratello Alfredo, la Società si trasforma in Costante Sesino & C.*

1945

Finished the II World War, among the several difficulties, Costante Sesino & C. restarted the production of radiators, evaporators and condensers. *Terminata la seconda guerra mondiale, tra le mille difficoltà dei tempi, la Costante Sesino & C. ricomincia a produrre radiatori, evaporatori e condensatori.*

1948

Began the production of radiators for cars, trucks and tractors for the spare parts market. This activity absorbed entirely Costante Sesino production for more than a decade. *Inizia la produzione di radiatori per auto, autocarri e trattori destinata al mercato del ricambio, che occupa la Costante Sesino & C. in maniera esclusiva per oltre un decennio.*

1954

Construction of the new company headquarter in Via Doberdò, Milan, which after further enlargements reached a covered area of 2500 m². *Costruzione della nuova sede di Via Doberdò, sempre a Milano che, con vari successivi ampliamenti, raggiunge una superficie coperta di oltre 2500 m².*

1955

Against request of a producer of injection presses for plastic material, who was forced to supply in the USA, Costante Sesino & C. started the production of tube-bundle heat exchangers for oil cooling in oleo hydraulic systems. *Su sollecitazione di un costruttore di presse a iniezione per materie plastiche, costretto ad approvvigionarsi degli scambiatori di calore a fascio tubiero negli Stati Uniti, la Costante Sesino & C. inizia la produzione di scambiatori di calore a fascio tubiero per il raffreddamento dell'olio di impianti oleoidraulici.*

1960

Using the experience in the construction of radiators, Costante Sesino & C. began producing air-oil heat exchangers intended to cool mobile and industrial machine's systems, combined radiators for the cooling of water and oil, exchanger for compressors and radiators for power units. *Sfrut-*

tando l'esperienza precedente nella costruzione di radiatori, la Costante Sesino & C. inizia la produzione di scambiatori di calore aria-olio destinati al raffreddamento di macchine mobili e industriali, alla costruzione di radiatori combinati per raffreddamento acqua e olio, al raffreddamento di compressori, alla costruzione di radiatori per gruppi elettrogeni.

1970

The production of radiators for the spare parts market was definitely abandoned in order to concentrate exclusively on the oleo hydraulic market. *Viene deciso di abbandonare la produzione di radiatori per il mercato del ricambio per dedicarsi esclusivamente al mercato oleoidraulico.*

1988

Began the production of aluminum air-oil heat exchangers, which will onwards substitute the brass/copper production. *Inizia la produzione di scambiatori aria-olio in alluminio che andrà progressivamente a sostituire negli anni successivi quella in ottone/rame.*

1999

The company Costante Sesino becomes part of the Tognella Group. *La società Costante Sesino entra a far parte del gruppo Tognella.*

2003

Costante Sesino S.p.A. moved to the current seat in Gessate (Milan): a modern place with a 4000 m² producing area and 400 m² offices. *Trasferimento della Costante Sesino S.p.A. nell'attuale sede di Gessate in provincia di Milano: si tratta di una moderna sede industriale di oltre 4000 m² di superficie produttiva, oltre a 400 m² di uffici.*

2009

Introduction of custom-made heat exchangers with different materials and size, addressed mainly to the energy market. *Introduzione di una produzione di scambiatori speciali, destinati al mercato energetico, costruiti con materiali diversi dallo standard, e fornibili con specifiche certificazioni richieste dai clienti.*

2011

Costante Sesino obtained the Certification EN ISO 9001/2008. *Raggiungimento della certificazione di qualità ISO 9001/2008.*

2012

Costante Sesino obtained the OHSAS 18001/2007 Certification for occupational health and safety management system. *Raggiungimento della certificazione OHSAS 18001/2007 per la salute e la sicurezza sul lavoro.*

2017

The company returns entirely to the ownership of the Sesino family. *La società ripassa definitivamente al 100% nella mani della famiglia Sesino.*

2019

Costante Sesino proudly celebrates the company's centenary. *Costante Sesino festeggia con grande orgoglio il centenario della società.*

2020

Significant investments in automation and production management. *2020 Ingenti investimenti per l'automazione e gestione della produzione.*

2021

Introduction of the new MSG shell and tube heat exchanger line, eliminating welding entirely. *2021 Inserimento della nuova linea di scambiatori fascio tubiero MSG con eliminazione definitiva di saldature.*

2022

Definitive establishment in the compressor market with high-pressure shell and tube heat exchangers for hydrogen and other gases. *Affermazione definitiva nel settore compressori con gli scambiatori fascio tubiero alta pressione per idrogeno e altri gas.*

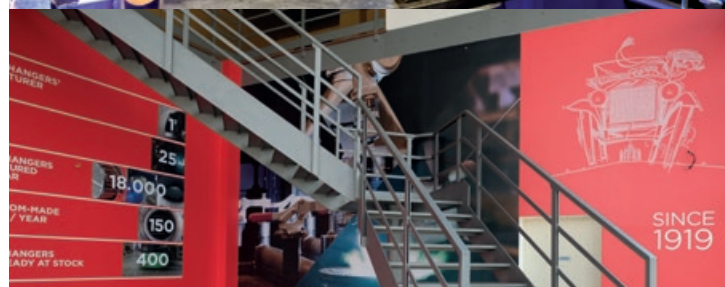
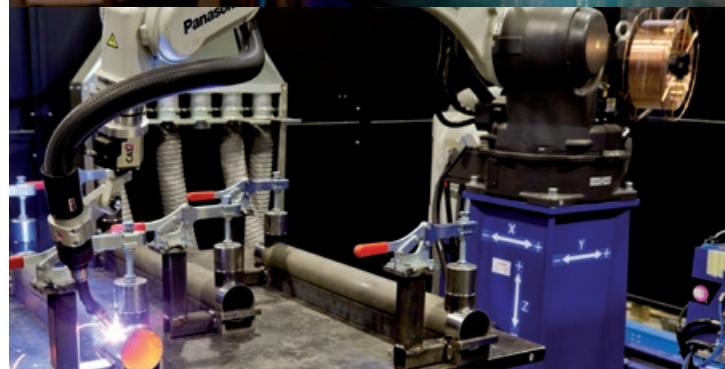

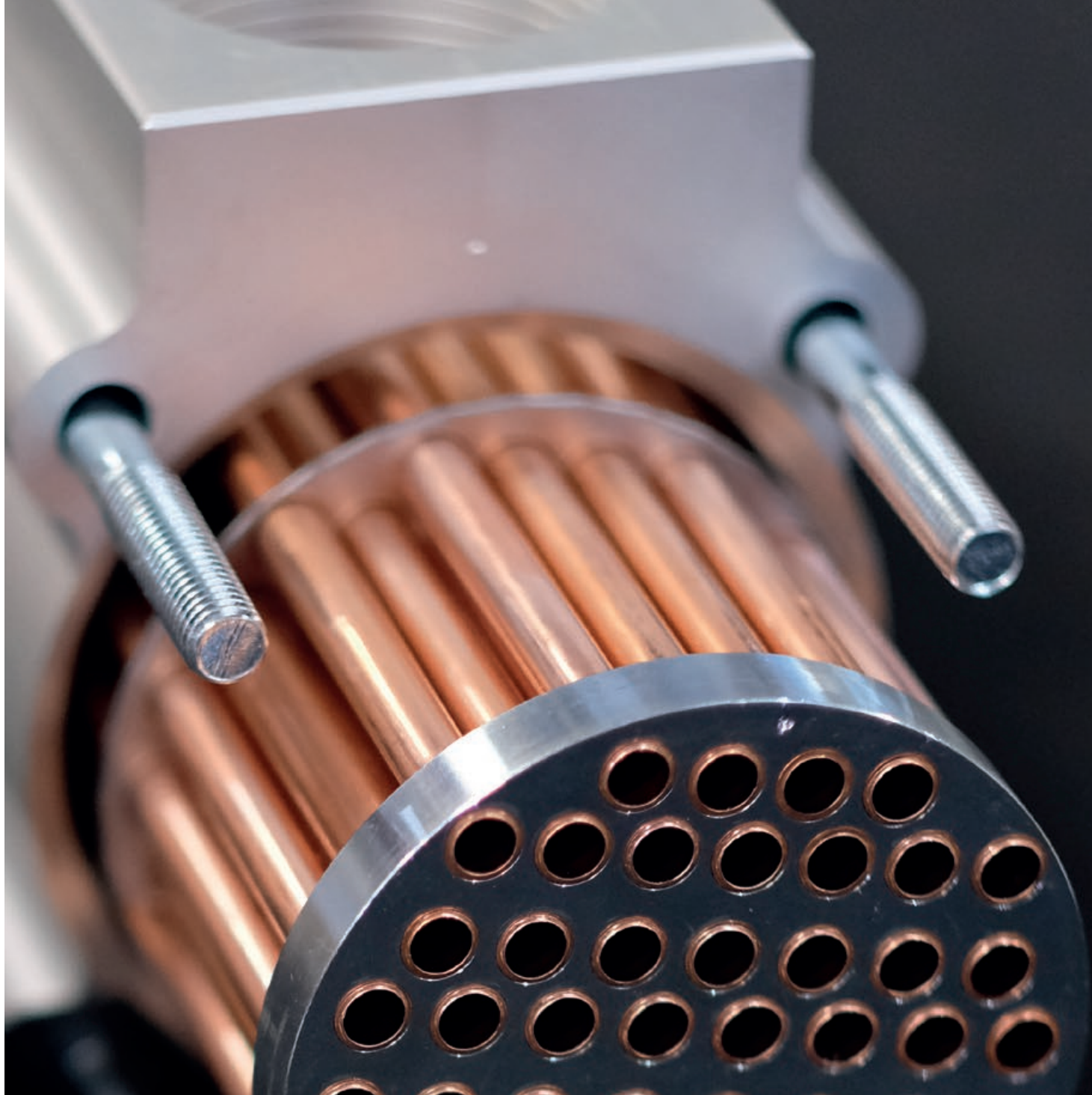

LEGENDA

P = power of the plant [kW] *potenza dell'impianto*

\dot{Q} = thermal power [kWt] *potenza termica*

\dot{Q}_d = adjusted thermal power [kWt] *potenza termica effettiva*

F = correction factor *fattore correzione*

$\dot{m}_{v_{oil}}$ = oil flow rate [l/min] *portata olio*

$\dot{m}_{v_{H_2O}}$ = water flow rate [l/min] *portata acqua*

T_{inH_2O} = inlet water temperature [°C] *temperatura entrata acqua*

T_{outH_2O} = outlet water temperature [°C] *temperatura uscita acqua*

T_{inoil} = inlet oil temperature [°C] *temperatura entrata olio*

T_{outoil} = outlet oil temperature [°C] *temperatura uscita olio*

$\Delta T_{m_{oil}}$ = oil temperature difference [°C] *salto termico olio*

$\Delta T_{m_{H_2O}}$ = water temperature difference [°C] *salto termico acqua*

ΔT_m = arithmetic mean temperature [°C] *differenza media temperatura*

ΔT_m = arithmetic mean temperature [°C] *differenza media temperatura*

Δp_{maxoil} = maximum oil pressure drop [bar] *perdite di carico max lato olio*

Cp_{oil} = oil specific heat [KJ/KgK] *calore specifico olio*

Cp_{H_2O} = water specific heat [KJ/KgK] *calore specifico acqua*

ρ_{oil} = oil density [Kg/l] *densità olio*

ρ_{water} = water density [Kg/l] *densità acqua*

HEAT EXCHANGING: GENERAL INFORMATION

GENERALITÀ SULLA TRASMISSIONE DEL CALORE

How heat is transferred

The term heat transmission means the processes through which heat is transferred from one body to another or from different points of the same body, because of the presence of temperature differences. The transmission way changes according to the nature of the body. In a solid body, heat is transferred by conduction, in a liquid by convection, while the third method, radiation, depends on the electromagnetic properties of the bodies involved. This last case is not particularly relevant in the heat exchangers field and thus, only the first two phenomena will be briefly described.

Conduction

Let us suppose that we have a flat plate and that the two faces of the plate are in some way kept at two different temperatures: T1 and T2. There will be a flow of heat from the face with a higher temperature T1 to the one with a lower temperature T2, without any movement of matter. We say that heat is transmitted from one point to another by conduction.

Convection

Now let us consider the case of a body immersed in a fluid. If the temperature of the body is higher than that of the fluid, heat will flow from the former to the latter. Since the temperature of the fluid in contact with the wall is higher than the one of the fluid distant from the wall, a movement is established because of the different densities at the two points. The phenomenon of heat transmission related to this state of motion is called convection.

While conductivity depends exclusively on the material, heat exchange by convection depends on the type of fluid, its condition of motion and the shape of the surface.

General information on heat exchangers and their sizing

Heat exchangers are devices, which allow the exchange of heat between two moving fluids at different temperatures. The two fluids are generally separated by a solid surface, which is usually metal. Heat exchangers can be divided into three groups according to the motion of the two fluids inside.

- parallel current heat exchanger, when the two fluids move in parallel and in the same direction at all points of the exchanger;
- counter current heat exchangers, where the two fluids move in parallel but in opposite directions;
- crosscurrent heat exchangers, where the two fluids move at right-angles to each other.

Sizing a heat exchanger means to calculate the needed exchange surface which is a function of the quantity of heat to dissipate, of the temperatures and the oil flow rates of the two fluids.

Problems regarding oil cooling

The viscosity of oil increases as its temperature decreases. When oil encounters a cold surface in a heat exchanger, it forms an isolating stratum. The thickness of this stratum is inversely proportional to the possibility of heat exchange.

To obtain optimal thermal efficiency, the flow rate of the oil over the exchange surface must be such as to ensure that the thickness of this stratum is as low as possible. In practice, this means that it is essential to ensure that the flow rate of the oil inside the heat exchanger is higher than the minimum indicated on the catalogues.

Sizing of water-oil heat exchangers to be installed on hydraulic systems

While choosing a heat exchanger it is necessary to consider two features related to the plant: the thermal power to dissipate and the pressure drops that derives from the friction forces produced by the fluid's motion. We suggest therefore taking into account the following aspects:

- Considering that the total efficiency into the oleo hydraulic plants is about 70-80%, in order to establish the thermal power, we adopt a 30-20% of the power installed.

- To count the fouling factor inside the heat exchanger and the uncertainty with which the film coefficients are established, we adopt an appropriate overdesign.

- As concern the sizing of the plant, the maximum allowable pressure drops on both exchanger's side are related to the head of the pump and to the piping system. In most cases, an increase of the maximum allowable pressure drops entails a reduction in the exchanger dimensions and an increase of the pump size.

We report here following an example, useful to guide while choosing a heat exchanger.

Example: sizing a tube-bundle heat exchanger to cool hydraulic oil with water. The oil is an ISO VG 46 type and has in inlet temperature $T_{in\text{oil}}=50$ [°C] with volumetric flow rate $m_{v\text{oil}}=150$ [l/min]. The power installed is 42[kW] we have water with inlet temperature in $T_{in\text{H}_2\text{O}}=20$ [°C] and flow rate $m_{v\text{H}_2\text{O}}=60$ [l/min]. The maximum oil side pressure drop is $\Delta p_{\text{maxoil}}=1$ [bar].

Determine the thermal power with the following relation:
 $\dot{Q} = P \cdot 0,5 = 42$ [kW] $\cdot 0,5 = 21$ [kWt]

The factor 0,5 is an empirical value that take account of both the efficiency of the plant and the fouling.

Define the outlet oil temperature and the oil temperature difference:

$$\Delta T_{\text{oil}} = \frac{\dot{Q}}{Cp_{\text{oil}} \cdot mv_{\text{oil}} \cdot \rho_{\text{oil}}} = \frac{21 \text{ [kWt]}}{2 \text{ [KJ/KgK]} \cdot 150/60 \text{ [l/s]} \cdot 0,84 \text{ [kg/l]}} = 5 \text{ [}^\circ\text{C]}$$

$$T_{\text{outoil}} = T_{\text{inoil}} - \Delta T_{\text{oil}} = 50 \text{ [}^\circ\text{C]} - 5 \text{ [}^\circ\text{C]} = 45 \text{ [}^\circ\text{C]}$$

Determine the outlet water temperature and the water temperature difference:

$$\Delta T_{\text{H}_2\text{O}} = \frac{\dot{Q}}{Cp_{\text{H}_2\text{O}} \cdot mv_{\text{H}_2\text{O}} \cdot \rho_{\text{H}_2\text{O}}} = \frac{21 \text{ [kWt]}}{4,186 \text{ [KJ/KgK]} \cdot 60/60 \text{ [l/s]} \cdot 1 \text{ [kg/l]}} = 5 \text{ [}^\circ\text{C]}$$

$$T_{\text{outH}_2\text{O}} = T_{\text{inH}_2\text{O}} + \Delta T_{\text{H}_2\text{O}} = 25 \text{ [}^\circ\text{C]}$$

Remark: in the event that the water flow rate is unknown we suggest the following steps

- if $T_{\text{H}_2\text{Oin}} < 20$ [°C] suppose $\Delta T_{\text{H}_2\text{O}}=10$ [°C]
- if $T_{\text{H}_2\text{Oin}} > 20$ [°C] suppose $\Delta T_{\text{H}_2\text{O}}=5$ [°C]

Consequently, we establish the water flow rate as follow:

$$mv_{\text{H}_2\text{O}} = \frac{\dot{Q}}{Cp_{\text{H}_2\text{O}} \cdot \rho_{\text{H}_2\text{O}} \cdot \Delta T_{\text{H}_2\text{O}}}$$

Calculate the arithmetic mean temperature and the adjusted thermal power $\dot{Q}d$ (refer to the correction factor table in the event that the arithmetic mean temperature is different from 25[°C]).

$$Tm_{\text{oilo}} = \frac{T_{\text{outoilo}} + T_{\text{inoilo}}}{2} = 47,5 \text{ [}^\circ\text{C]}$$

$$Tm_{\text{H}_2\text{O}} = \frac{T_{\text{outH}_2\text{O}} + T_{\text{inH}_2\text{O}}}{2} = 22,5 \text{ [}^\circ\text{C]}$$

$$Tm = Tm_{\text{oilo}} - Tm_{\text{H}_2\text{O}} = 25 \text{ [}^\circ\text{C]}$$

$$\dot{Q}d = \dot{Q} \cdot F$$

Consult the performance curves, cross-check the values of the adjusted thermal power $\dot{Q}d$, of the oil flow rate and the water flow rate

Check the oil pressure drop using the "pressure drop" curves.

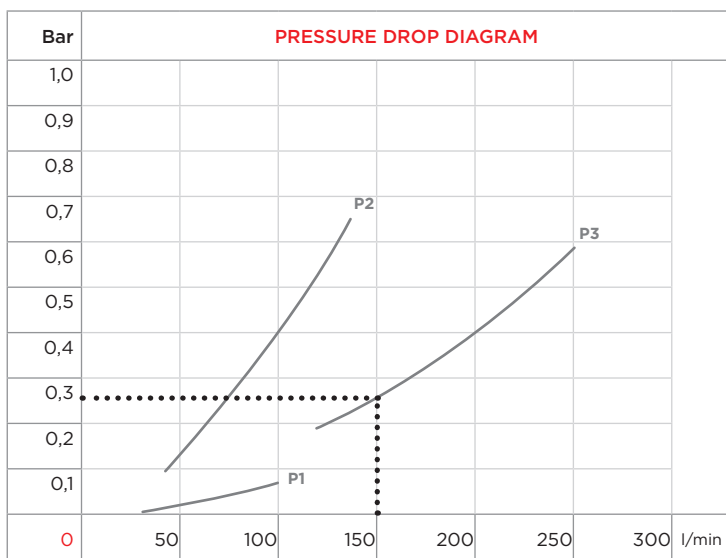
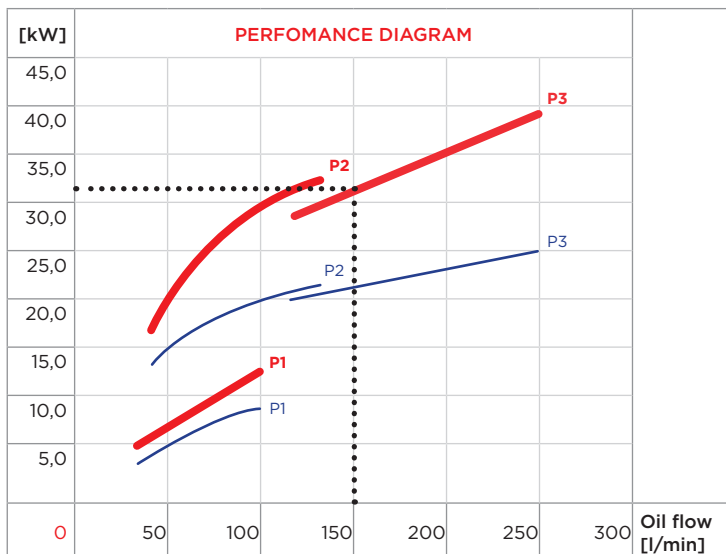

Sizing of air-oil heat exchangers to be installed on hydraulic systems.

The technical data required are the same of water-oil heat exchangers, as well as the ambient temperature at which the heat exchangers has to work.

Sizing air-oil heat exchangers consists, practically, in calculating the needed specific performance, called Kr, and choosing the heat exchanger having the higher specific performance.

$Kr = Q/\Delta T$ where ΔT is the difference between oil inlet temperature and maximum summer ambient temperature, while Q is the quantity of heat to be dissipated which can be easily calculated considering 20-30% of installed power.

To choose the right cooler you must check the diagrams into the technical catalogue.

Example

N = 20 kW
 q = 80 lpm
 To = 50°C
 Tamb = 30°C

Q = 30% 20 = 6 kW = 5.160 kcal/h
 $\Delta T = 50 - 30 = 20^\circ C$
 $Kr = 5.160/20 = 258 \text{ kcal/h}^\circ C$

Drawing a vertical line on the diagram in correspondence of the flow rate 80 l/min, the intersection of this line with the curves gives on ordinates the Kr that each heat exchanger is able to grant in that condition.

Le vie del calore

Tutti sanno che per "trasmissione del calore" si intendono i processi attraverso cui, a causa di differenze termiche esistenti, il calore si trasferisce da un corpo ad un altro o a punti diversi dello stesso corpo. Queste modalità, ovviamente, cambiano a seconda che si verifichino in un solido (conduzione), in un liquido (convezione) o per le proprietà elettromagnetiche dei corpi (irraggiamento).

La conduzione

Supponiamo di avere una lastra piana e di mantenere con qualsiasi artificio le due facce a due temperature diverse: $T1 > T2$. Vi sarà un flusso di calore dalla faccia a temperatura superiore a quella a temperatura inferiore senza movimento di materia; diremo che il calore si trasmette da un punto ad un altro per conduzione.

La convezione

Consideriamo di avere un corpo immerso in un fluido; se la temperatura del corpo è superiore a quella del fluido, vi sarà un flusso di calore dal primo al secondo.

Poiché la temperatura del fluido a contatto con la parete è più alta di quella di un punto lontano dalla parete, si stabilisce un movimento causato dalle diverse densità nei due punti: il fenomeno di trasmissione del calore che è legato a questo stato di moto si chiama convezione.

A differenza della conducibilità che dipende esclusivamente dal materiale, il calore scambiato per convezione trova le sue ragioni, oltre che nel tipo di fluido, nelle condizioni di moto di questo e nella forma della superficie.

Generalità sugli scambiatori di calore e loro dimensionamento

Gli scambiatori di calore sono apparecchi che consentono lo scambio del calore tra due fluidi in movimento a diverse temperature. I due fluidi sono generalmente separati tra loro da una superficie solida, quasi sempre metallica.

Gli scambiatori di calore, in relazione al moto dei due fluidi all'interno dell'apparecchio, si possono dividere in tre gruppi:

- scambiatori in equicorrente, se i due fluidi si muovono in ogni punto dell'apparecchio parallelamente e nella stessa direzione;
- scambiatori in controcorrente, se i due fluidi si muovono parallelamente, ma in direzioni opposte;
- scambiatori a correnti incrociate, se il flusso dei fluidi è ortogonale.

Dimensionare uno scambiatore significa calcolare la superficie di scambio necessaria, che è funzione della quantità di calore da disperdere, delle temperature e delle portate dei due fluidi.

Problemi inerenti al raffreddamento dell'olio

L'olio è un fluido che, con il diminuire della temperatura, aumenta la sua viscosità. Quando in uno scambiatore di calore esso viene a contatto con una superficie fredda, esso forma uno strato isolante il cui spessore è inversamente proporzionale alla possibilità di scambiare calore.

Per ottenere una resa termica ottimale bisogna fare in modo che la velocità di scorrimento dell'olio sulla superficie di scambio sia tale da rendere il più basso possibile lo spessore di tale strato; ciò in pratica si traduce nella assoluta esigenza che negli scambiatori circoli una portata d'olio superiore alla minima indicata sui cataloghi.

Scambiatori di calore acqua-olio per impianti oleoidraulici

Dimensionamento degli scambiatori di calore acqua-olio da installare su impianti oleoidraulici

Nella scelta dello scambiatore bisogna considerare due aspetti legati all'impianto, la potenza termica da trasferire al fluido di raffreddamento e le perdite di carico all'interno dello scambiatore dovute alle inevitabili forze d'attrito indotte dal moto dei fluidi. Consigliamo di tener conto dei seguenti aspetti:

- considerando che il rendimento totale negli impianti oleoidraulici si aggira intorno al 70-80%, per determinare la potenza termica da trasferire al circuito di raffreddamento, si adotta un 30%-20% della potenza installata in centralina.
- per tenere conto dello sporco all'interno dello scambiatore e delle incertezze con le quali si determinano i coefficienti di scambio si adotta un opportuno overdesign.

- dal punto di vista del dimensionamento dell'impianto, le perdite di carico massime ammissibili su entrambi i circuiti dello scambiatore sono correlate alla prevalenza della pompa di circolazione e al sistema di raccordi e tubazioni; nella maggior parte dei casi un aumento delle perdite di carico massime ammissibili implica una diminuzione delle dimensioni dello scambiatore a scapito di un aumento delle dimensioni del sistema di pompaggio.

Di seguito si illustra un esempio utile al fine di guidare la scelta dello scambiatore.

Esempio: Si dimensiona uno scambiatore di calore a fascio tubiero per raffreddare olio idraulico con acqua di rete. L'olio è classificato come ISO VG 46 e ha una temperatura in ingresso allo scambiatore pari a $T_{inolio} = 50 [^{\circ}C]$ con portata volumetrica $m_{volio} = 150 [l/min]$. La potenza installata in centralina è pari a $42 [kW]$ mentre si ha a disposizione acqua alla temperatura $T_{inH2O} = 20 [^{\circ}C]$ con portata volumetrica $m_{vH2O} = 60 [l/min]$. La massima perdita di carico sull'olio è pari a $\Delta p_{maxolio} = 1 [bar]$.

Si determina la potenza termica da smaltire tramite la seguente relazione $\dot{Q} = P \cdot 0,5 = 42 [kW] \cdot 0,5 = 21 [kW]$

Il fattore 0,5 è un valore empirico che tiene conto sia del rendimento dell'impianto che dello sporcamento.

Si determina la temperatura d'uscita dell'olio dallo scambiatore e il salto termico dell'olio:

$$\Delta T_{olio} = \frac{\dot{Q}}{Cp_{olio} \cdot mv_{olio} \cdot \rho_{olio}} = \frac{21 [kW]}{2 [KJ/KgK] \cdot 150/60 [l/s] \cdot 0,84 [kg/l]} = 5 [^{\circ}C]$$

$$T_{outolio} = T_{inolio} - \Delta T_{olio} = 50 [^{\circ}C] - 5 [^{\circ}C] = 45 [^{\circ}C]$$

Si determina la temperatura d'uscita dell'acqua e il salto termico dell'acqua di raffreddamento:

$$\Delta T_{H2O} = \frac{\dot{Q}}{Cp_{H2O} \cdot mv_{H2O} \cdot \rho_{H2O}} = \frac{21 [kW]}{4.186 [KJ/KgK] \cdot 60/60 [l/s] \cdot 1 [kg/l]} = 5 [^{\circ}C]$$

$$T_{outH2O} = T_{inH2O} + \Delta T_{H2O} = 25 [^{\circ}C]$$

NOTA: nel caso in cui non si conosca a priori la portata volumetrica d'acqua consigliamo il seguente criterio

se $T_{inH2O} < 20 [^{\circ}C]$ allora ipotizzare $\Delta T_{H2O} = 10 [^{\circ}C]$

se $T_{inH2O} > 20 [^{\circ}C]$ allora ipotizzare $\Delta T_{H2O} = 5 [^{\circ}C]$

Di conseguenza, la portata d'acqua volumetrica si determina come di seguito:

$$mv_{H2O} = \frac{\dot{Q}}{Cp_{H2O} \cdot \rho_{H2O} \cdot \Delta T_{H2O}}$$

Si determina la temperatura media aritmetica e il fattore di correzione da applicare alla potenza termica Q, in maniera tale da determinare la Qd (consultare la tabella corrispondente nel caso in cui la temperatura media aritmetica sia differente dai 25 [^{\circ}C]).

$$Tm_{olio} = \frac{T_{outolio} + T_{inolio}}{2} = 47,5 [^{\circ}C]$$

$$Tm_{H2O} = \frac{T_{outH2O} + T_{inH2O}}{2} = 22,5 [^{\circ}C]$$

$$Tm = Tm_{olio} - Tm_{H2O} = 25 [^{\circ}C]$$

$$\dot{Q}d = \dot{Q} \cdot F$$

Calcolata la Qd si consultano i diagrammi di performance incrociando i valori della potenza termica corretta Qd, della portata volumetrica d'olio e della portata volumetrica d'acqua come nell'esempio che segue

Si verificano che le perdite di carico siamo entro i limiti ammissibili utilizzando il grafico 'pressure drop' come illustrato di seguito:

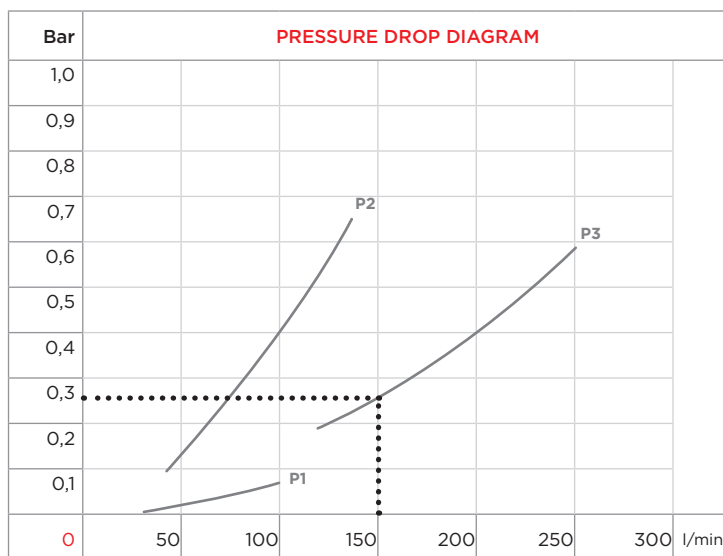
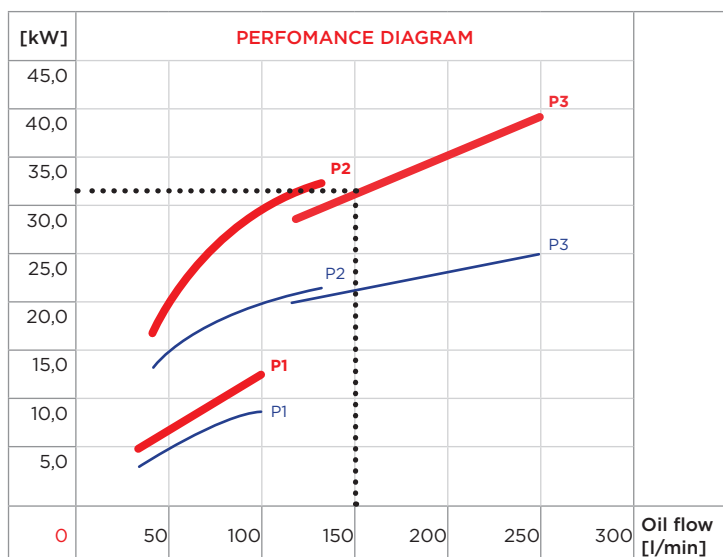

Dimensionamento degli scambiatori di calore aria-olio da installare su impianti oleoidraulici

I dati da richiedere sono gli stessi dello scambiatore acqua-olio, oltre, naturalmente, alla temperatura dell'aria ambiente a cui deve funzionare lo scambiatore.

Il dimensionamento dello scambiatore consiste essenzialmente nel calcolo della potenzialità specifica necessaria, chiamata Kr, e scegliere lo scambiatore avente potenzialità specifica immediatamente superiore.

$Kr = Q/\Delta T$, dove ΔT è la differenza tra la temperatura entrata olio e la temperatura ambiente massima estiva e Q è la quantità di calore da disperdere che si calcola considerando il 20-30% della potenza installata.

Per scegliere lo scambiatore idoneo bisogna consultare i diagrammi del catalogo tecnico. Tracciando sui diagrammi una retta verticale in corrispondenza della portata 80 l/min, l'intersezione di tale retta con le curve fornisce in ordinate il Kr che ogni scambiatore è in grado di garantire in quella condizione.

Esempio: $N = 20 [kW]$; $q = 80 [lpm]$; $To = 50 [^{\circ}C]$; $Tamb = 30 [^{\circ}C]$

$$Q = 30\% 20 = 6 [kW] = 5.160 [kcal/h]$$

$$\Delta T = 50 - 30 = 20 [^{\circ}C]$$

$$Kr = 5.160/20 = 258 [kcal/h^{\circ}C]$$

La scelta dello scambiatore si esegue utilizzando le curve presenti sul catalogo tecnico. Tracciando una retta verticale in corrispondenza della portata di 80 lpm, l'intersezione con le varie curve di resa fornisce in ordinate il Kr dei diversi scambiatori.

WATER-OIL HEAT EXCHANGERS SCAMBIATORI ACQUA-OLIO

with removable tube bundle



MSG 84	p. 16-17
MSG 134	p. 18-19
MS 84 P INOX	p. 20-21
MS 134 P INOX e CuNi	p. 22-23
MS 84/2B MARINE USE	p. 24-25



MS 152/7 P	p. 28-29
MS 152/10 P	p. 30-31
MS 172/7 P	p. 32-33
MS 172/10 P	p. 34-35
MS 202 P	p. 36-37
MS 272 P	p. 38-39
MS 352 P	p. 40-41

not inspectable water side outside/inside the tank



T60-80 CB	p. 44-45
-----------	----------

WATER-OIL HEAT EXCHANGERS WITH BRAZED PLATES SCAMBIATORI ACQUA-OLIO A PIASTRE SALDOBRSATE

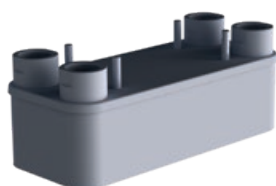

M5 S	p. 50
M18 S	p. 51
M25 S	p. 52
M55 S	p. 53

GASKET PLATE HEAT EXCHANGERS	p. 55
------------------------------	-------

AC MOTOR AIR-OIL HEAT EXCHANGERS SCAMBIATORI ARIA-OLIO CON VENTILATORE AC



AP 178 E	p. 58
AP 260 E	p. 59
AP 300 E	p. 60
AP 300/2 E	p. 61
AP 430 E	p. 62
AP 430/2 E	p. 63
AP 494 EB	p. 64
AP 580 EB	p. 65
AP 680 EB	p. 66
AP 730 EB	p. 67
AP 830 EB	p. 68
AP 1200 EB	p. 69
AP 2/680 EB	p. 70
AP 2/730 EB	p. 71
AP 2/830 EB	p. 72
AP 3/830 EB	p. 73

AC MOTOR AIR-OIL HEAT EXCHANGERS MARINE USE EM TYPE SCAMBIATORI ARIA-OLIO CON VENTILATORE AC USO MARINO SERIE EM



AP 300 EM	p. 76
AP 300/2 EM	p. 77
AP 430 EM	p. 78
AP 430/2 EM	p. 79
AP 494 EM	p. 80
AP 580 EM	p. 81
AP 680 EM	p. 82
AP 730 EM	p. 83
AP 830 EM	p. 84
AP 2/680 EM	p. 85
AP 2/730 EM	p. 86
AP 2/830 EM	p. 87
AP 3/830 EM	p. 88

AC MOTOR AIR-OIL HEAT EXCHANGERS MARINE USE AND ATEX REGULATION EMX TYPE

*SCAMBIATORI ARIA-OLIO CON VENTILATORE AC USO MARINO
NORME ATEX SERIE EMX*



AP 300 EMX	p. 93
AP 300/2 EMX	p. 94
AP 430 EMX	p. 95
AP 430/2 EMX	p. 96
AP 494 EMX	p. 97
AP 580 EMX	p. 98
AP 680 EMX	p. 99
AP 730 EMX	p. 100
AP 830 EMX	p. 101
AP 2/680 EMX	p. 102
AP 2/730 EMX	p. 103
AP 2/830 EMX	p. 104
AP 3/830 EMX	p. 105

AIR-OIL HEAT EXCHANGERS WITH IDRAULIC MOTOR

SCAMBIATORI ARIA-OLIO CON VENTOLA AZIONATA DA MOTORE IDRAULICO



AP 300 I	p. 108
AP 300/2 I	p. 109
AP 430 I	p. 110
AP 430/2 I	p. 111
AP 494 I	p. 112
AP 580 I	p. 113
AP 680 I	p. 114
AP 730 I	p. 115
AP 830 I	p. 116
AP 2/680 I	p. 117
AP 2/730 I	p. 118
AP 2/830 I	p. 119

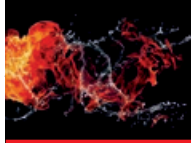

DC MOTOR AIR-OIL HEAT EXCHANGERS *SCAMBIATORI ARIA-OLIO CON VENTILATORE DC*



APL 170	p. 122
APL 240	p. 123
APL 263	p. 124
APL 300	p. 125
APL 300/2	p. 126
APL 430	p. 127
APL 430/2	p. 128
APL 494	p. 129
APL 580	p. 130
APL 2/463	p. 131
APL 2/494	p. 132
APL 2/580	p. 133

CONCRETE MIX COOLER *SCAMBIATORI PER MESCOLATORI DI CALCESTRUZZO*

ELRO 91261	p. 136
------------	--------

COOLING UNITS *UNITÀ DI RAFFREDDAMENTO*



RAS 1000	p. 140
RAS 3000	p. 141
RAS 5000	p. 142
RAS 7000	p. 143

In the new **MSG line** the welding of the tubes to the tube sheets have been replaced by an automated precision tube expanding, that ensures a high-quality level of the coupling and a constant production.

100% of the expanded tube bundles are pressure tested, as well as the 100% of the finished exchangers are pressure tested.

The MSG heat exchangers have a removable tube bundle that is very easy to assemble and disassemble or replace it with a new one.

The accuracy of the mechanical processing with very close tolerances and use of special seals allowed us to increase the thermic performance of around 10-15 % for the same external dimensions: the new line design is protected by patent already filed.

The MSG line is perfectly interchangeable with the old MS line.

Shell, manifolds and covers are not painted but anodised, gaining this way a better protection.

The materials that make up the new line are the following:

- **Tube-bundle tubes:** copper
- **Tube sheets:** hardened steel
- **Shell:** extruded anodised aluminum
- **Covers:** anodized die-cast aluminum
- **Seals Kit:** viton

Nella nuova serie MSG le saldature dei tubi alle piastre tubiere sono state sostituite da mandrinature effettuate con una mandrinatrice automatica garantendo un alto livello qualitativo dell'accoppiamento e una costanza di produzione.

Il 100% dei fasci tubieri mandrinati è collaudato a pressione, come collaudato a pressione è il 100% degli scambiatori finiti.

Gli scambiatori della serie MSG hanno il fascio estraibile ed abbiamo reso molto semplice il suo montaggio e rimontaggio o sostituzione con un fascio nuovo.

L'accuratezza delle lavorazioni meccaniche con tolleranze molto strette e l'impiego di guarnizioni speciali ci hanno consentito di ottenere aumenti di resa termica nell'ordine del 10-15% a parità di dimensioni esterne: il progetto della nuova serie è protetto da brevetto già depositato

La nuova serie MSG è perfettamente intercambiabile alla vecchia serie MS.

Mantello, collettori e testate non sono verniciati ma anodizzati, ottenendo in questo modo una protezione più efficace.

I materiali che compongono le nuove serie di scambiatori sono i seguenti:

- **Tubi fascio tubiero:** rame
- **Piastre tubiere:** acciaio bonificato
- **Mantello:** alluminio estruso anodizzato
- **Testate:** alluminio pressofuso anodizzato
- **Kit Guarnizioni:** viton

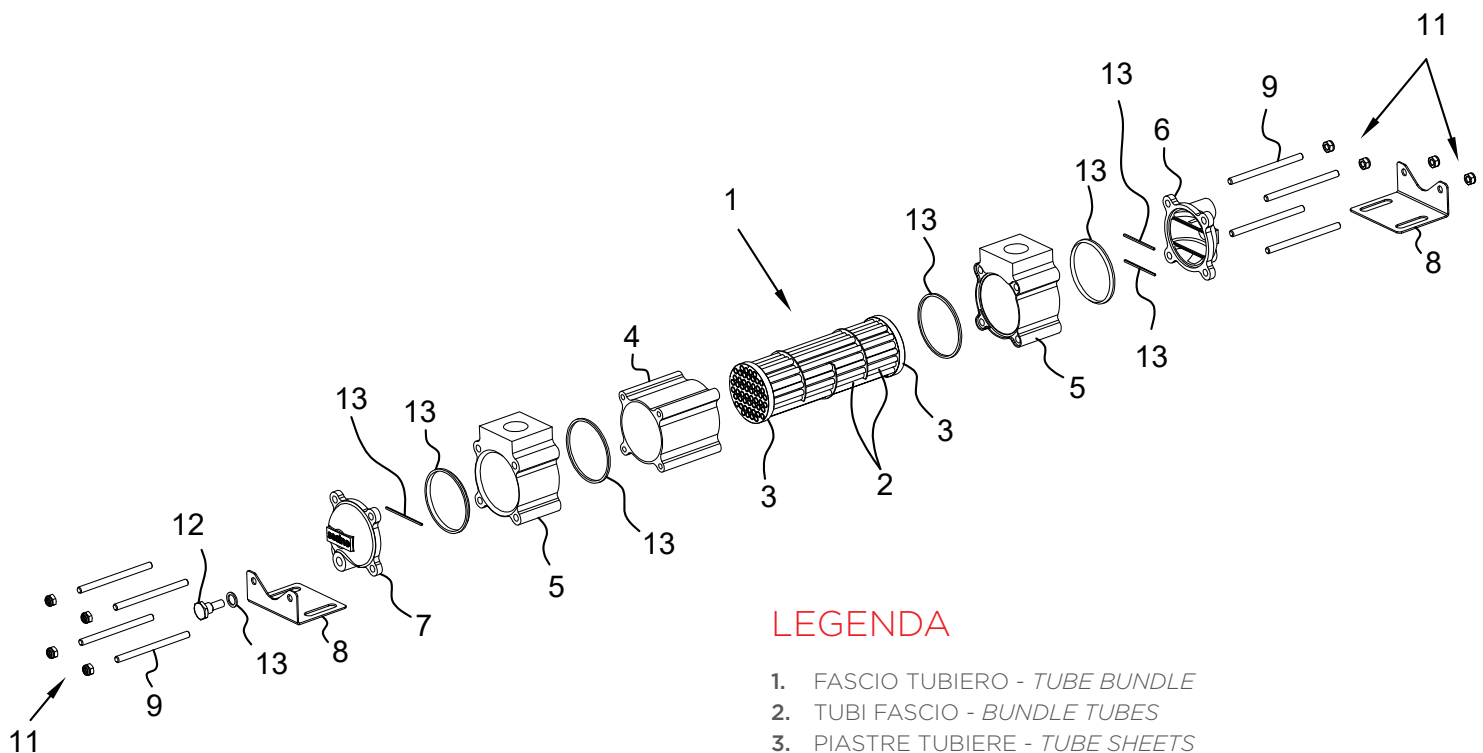

LEGENDA

1. FASCIO TUBIERO - TUBE BUNDLE
2. TUBI FASCIO - BUNDLE TUBES
3. PIASTRE TUBIERE - TUBE SHEETS
4. MANTELLO - SHELL
5. COLLETTORI MANTELLO - SHELL MANIFOLDS
6. TESTATA - HEAD COVER
7. FONDO - END COVER
8. SUPPORTI FISSAGGIO - FIXING SUPPORTS
9. VITI PRIGIONIERE - STUD SCREW
11. DADI - NUTS
12. TAPPO CON ANODO - ANODE PLUG
13. KIT GUARNIZIONI - SEALS KIT

SHELL AND TUBE HEAT EXCHANGERS

SCAMBIATORI DI CALORE ACQUA-OLIO A FASCIO TUBIERO

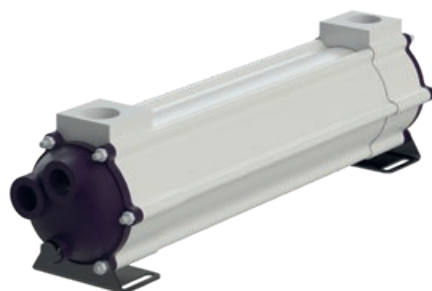

They consist of smooth tubes with little diameter; this allows the best compromise between high thermic performance and low pressure's losses.

The flow rates shown in the tables are the ones recommended for the exchanger proper working. Going down the lowest rate of flow indicated in the tables, the low oil speed causes a great loss in performance, whereas a rate of flow that is superior to maximum indicated causes great losses of pressure and does not considerably increase the thermic performance.

The efficiency diagrams indicate the heat quantity each exchanger can disperse according to the difference between oil and water mean temperatures.

Such diagrams refer to the exchangers working with the maximum oil rate indicated in the table.

The maximum working pressure allowed in the oil and water circuits is 12 bar

For the right calculation of tube bundle exchangers, we supply our customers a calculation program; by filling in some data, it is possible to establish the right exchanger and to obtain all the working parameters on a data sheet.

Tube bundle heat exchangers can be used with other kind of fluids, which must be compatible with copper and its alloys. However, for each use, with the exception of oil cooling, we recommend to consult our Technical Department.

Exchange surface from 0,2 to 3,6 m²

Sono costruiti con tubi lisci di piccolo diametro, raggiungendo in questo modo il miglior compromesso tra elevata resa termica e basse perdite di carico.

Le portate olio indicate nelle tabelle sono quelle consigliate per il buon funzionamento dello scambiatore. Andando al di sotto della portata minima indicata, la bassa velocità dell'olio causa un forte calo di rendimento, mentre una portata superiore alla massima causa perdite di carico notevoli, senza peraltro aumentare la resa termica in maniera apprezzabile.

I diagrammi di rendimento forniscono la quantità di calore in kW che ogni scambiatore è in grado di disperdere con $\Delta T=25^{\circ}\text{C}$ tra olio e acqua in funzione della portata olio circolante nello scambiatore.

La pressione di esercizio massima ammessa in entrambe i circuiti è 12 bar.

Per il calcolo esatto degli scambiatori a fascio tubiero possiamo fornire un programma; mediante il semplice inserimento di alcuni dati è possibile stabilire lo scambiatore necessario e ottenere tutti i parametri di funzionamento su un data-sheet.

Gli scambiatori a fascio tubiero possono essere utilizzati con altri tipi di fluidi, a condizione che essi siano compatibili con il rame e le sue leghe. Consigliamo comunque, per qualsiasi impiego che non sia il raffreddamento dell'olio, di consultare il nostro Ufficio Tecnico.

Superficie di scambio da 0,2 a 3,6 m²

Selection procedure

The curves are based on the following data:

- 1) Oil viscosity ISO VG 46
- 2) Arithmetic mean temperature between oil and water 25 [°C] (ΔT_m)

If your application parameters are different, follow these steps:

- 1) Define the arithmetic mean temperature [see the technical example on page 7] and select the correction factor from the table

CORRECTION FACTOR							
ΔT_m	10	15	20	25	30	35	40
f	2,5	1,67	1,25	1	0,83	0,71	0,63

- 2) Calculate the adjusted thermal power $\dot{Q}_d = \dot{Q} \cdot F$

- 3) Select the model from the curve
Cross-check on the diagram the values of the oil flow, of the water flow and of the thermal power.

Procedura di selezione dello scambiatore

Le curve riportate sono basate sulle seguenti assunzioni:

- 1) Viscosità cinematica dell'olio pari a 46 [cSt]
- 2) Temperatura media aritmetica tra i due fluidi pari a 25 [°C] (ΔT_m)

Se si ha una temperatura media aritmetica differente da 25 [°C], seguire la procedura sottostante:

- 1) Determinare la temperatura media aritmetica tra i due fluidi [vedere esempio a pagina 9 per effettuare il calcolo] e selezionare il fattore di correzione appropriato dalla tabella

CORRECTION FACTOR							
ΔT_m	10	15	20	25	30	35	40
f	2,5	1,67	1,25	1	0,83	0,71	0,63

- 2) Determinare la potenza termica da smaltire opportunamente corretta $\dot{Q}_d = \dot{Q} \cdot F$

- 3) Selezionare il modello
Incrociare i valori di portata volumetrica d'olio, d'acqua e della potenza termica corretta sull'apposito grafico

- Dimensions and technical characteristics are not binding

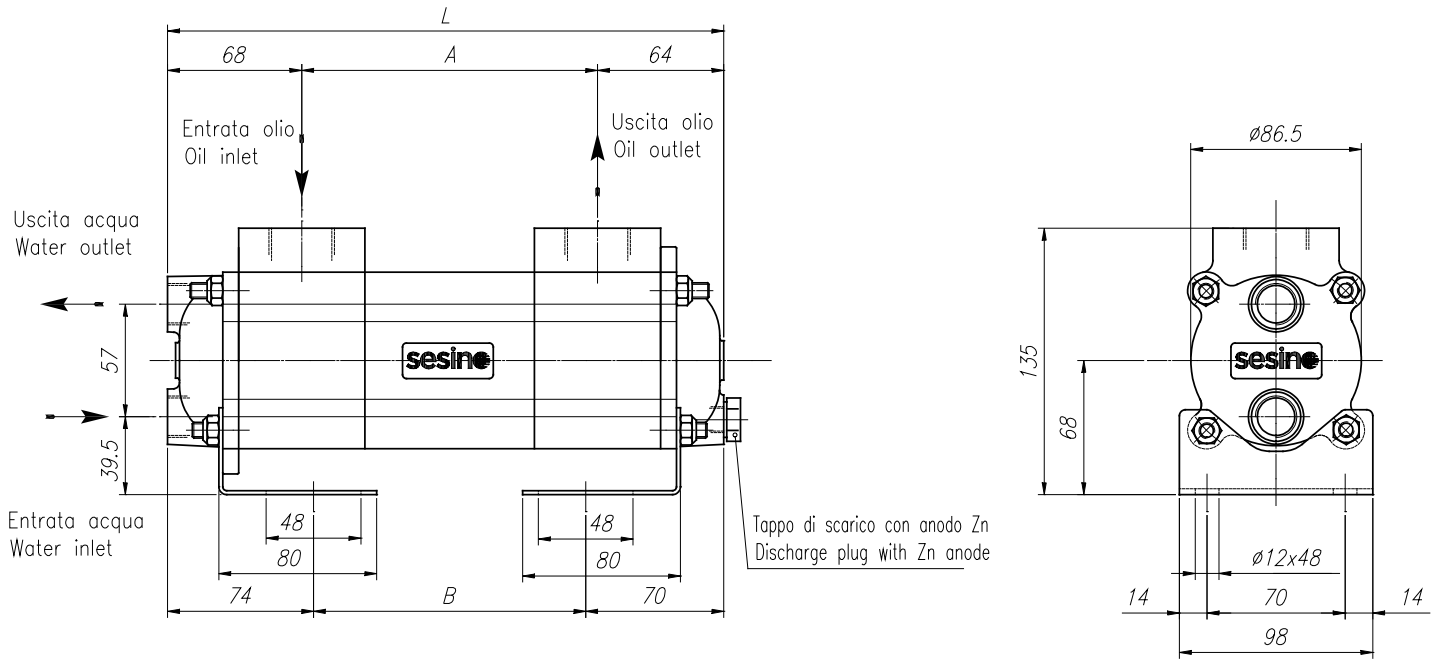

Static working pressure = 12 bar

Test pressure = 15 bar

Heat exchanged a $\Delta T_{in}=25^{\circ}C$ Potenza termica scambiata a $\Delta T_{in}=25^{\circ}C$ [kW]

Connections Connessioni

Type Tipo	Code Codice	Water flow Portata acqua [l/min]	Oil flow Portata olio [l/min]	min. water, min. oil flow min. acqua, min. olio	min. water, max. oil flow min. acqua, max. olio	max. water, min. oil flow- max. acqua, min. olio	max. water, max. oil flow max. acqua, max. olio	Water Acqua	Oil Olio	Oil connections distance Interasse connessioni olio A [mm]	Anchor point distance Interasse fori fissaggio B [mm]	Length Lunghezza L [mm]	Weight Peso [kg]
MSG 84 P1	2SCG84P1	7,5 - 30	30-80	2,2	3,3	2,86	4,62	G½	G1	150	138	282	4,5
MSG 84 P2	2SCG84P2	7,5 - 30	20-60	2,86	4,4	3,575	6,16	G½	G1	310	298	442	6,3
MSG 84 P3	2SCG84P3	7,5 - 30	50-100	3,96	4,84	5,06	8,8	G½	G1-½	310	298	442	6,5
MSG 84 P4	2SCG84P4	7,5 - 30	30-80	5,28	7,7	6,6	11	G½	G1	560	548	692	9
MSG 84 P5	2SCG84P5	7,5 - 30	80-130	6,6	7,7	7,7	9,9	G½	G1-½	560	548	692	9
MSG 84 P6	2SCG84P6	7,5 - 30	40-90	9,9	13,2	13,2	19,8	G½	G1-½	715	703	847	10,8
MSG 84 P7	2SCG84P7	7,5 - 30	100-160	12,1	15,4	16,5	23,1	G½	G1-½	715	703	847	10,9
MSG 84 P8	2SCG84P8	7,5 - 30	60-110	13,2	17,6	17,6	26,4	G½	G1-½	870	858	1002	12,3
MSG 84 P9	2SCG84P9	7,5 - 30	140-190	16,5	18,7	23,1	29,7	G½	G1-½	870	858	1002	12,3

CONSTRUCTION MATERIALS

SHELL	TUBES	END COVERS
Aluminum*	COPPER*	Aluminum*

*standard

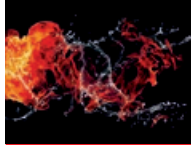

SHELL AND TUBE HEAT EXCHANGERS SCAMBIATORI ACQUA-OLIO A FASCIO TUBIERO



- Dimensions and technical characteristics are not binding

WATER FLOW RATE:

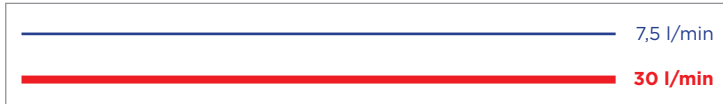

P1 P2 P3

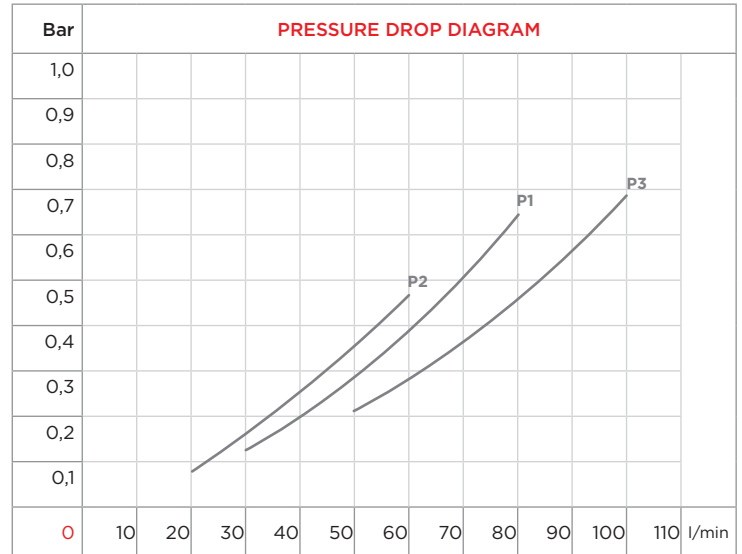
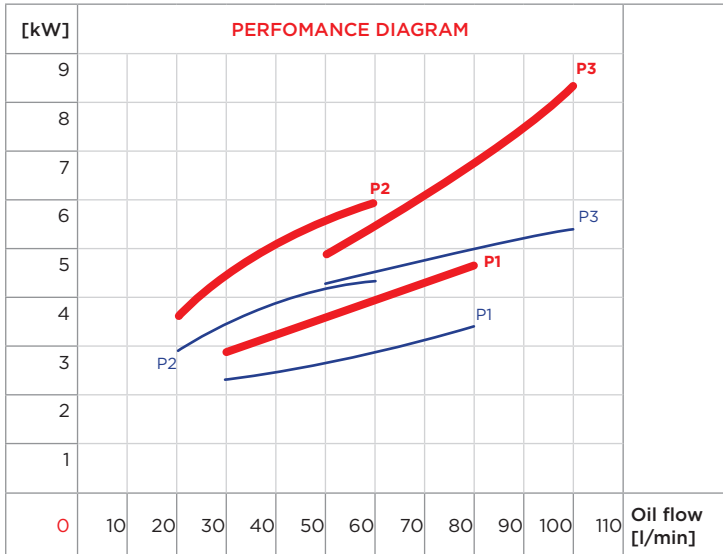

P4 P5 P6

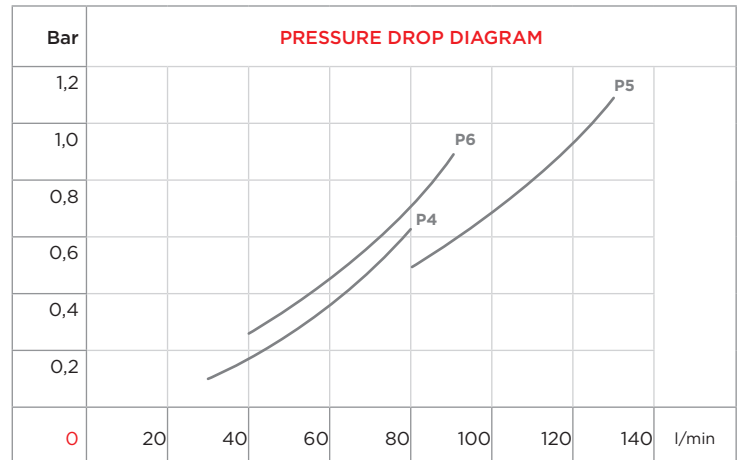
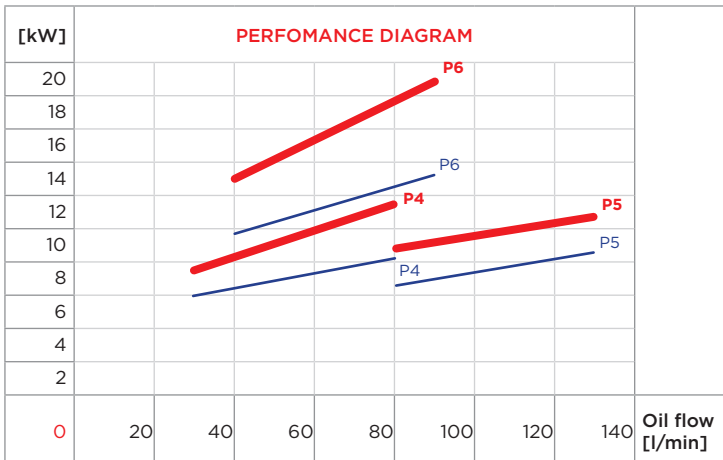

P7 P8 P9

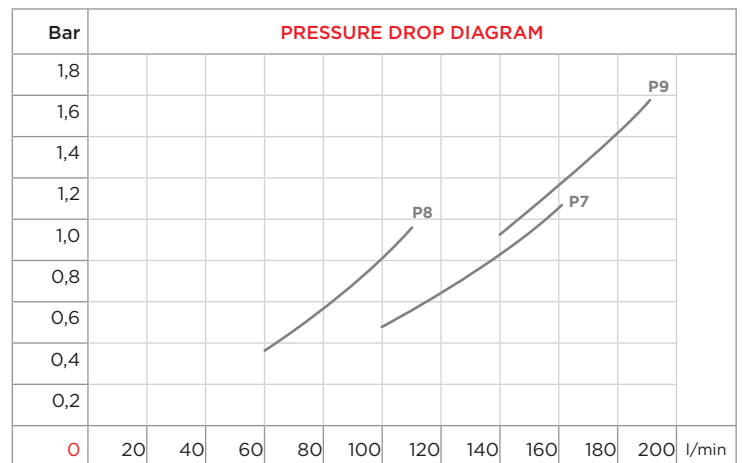
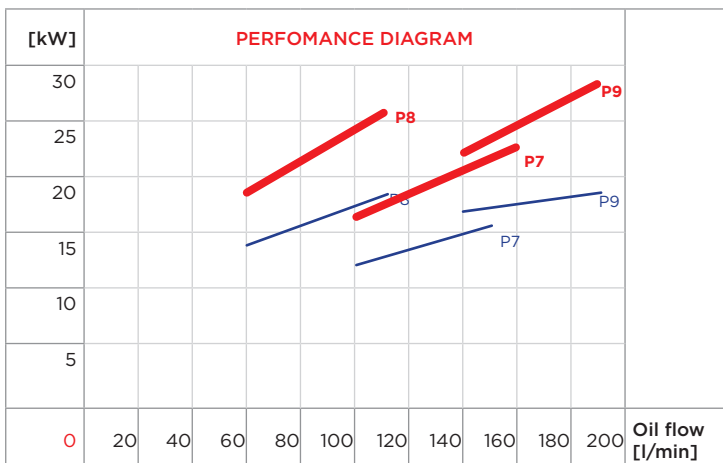

CORRECTION FACTOR								
ΔT_m	10	15	20	25	30	35	40	
f	2,5	1,67	1,25	1	0,83	0,71	0,63	

CORRECTION FACTOR								
cSt	22	30	46	68	100	150	220	
f	0,4	0,6	1	1,5	2,3	3,3	4,6	

- Dimensions and technical characteristics are not binding

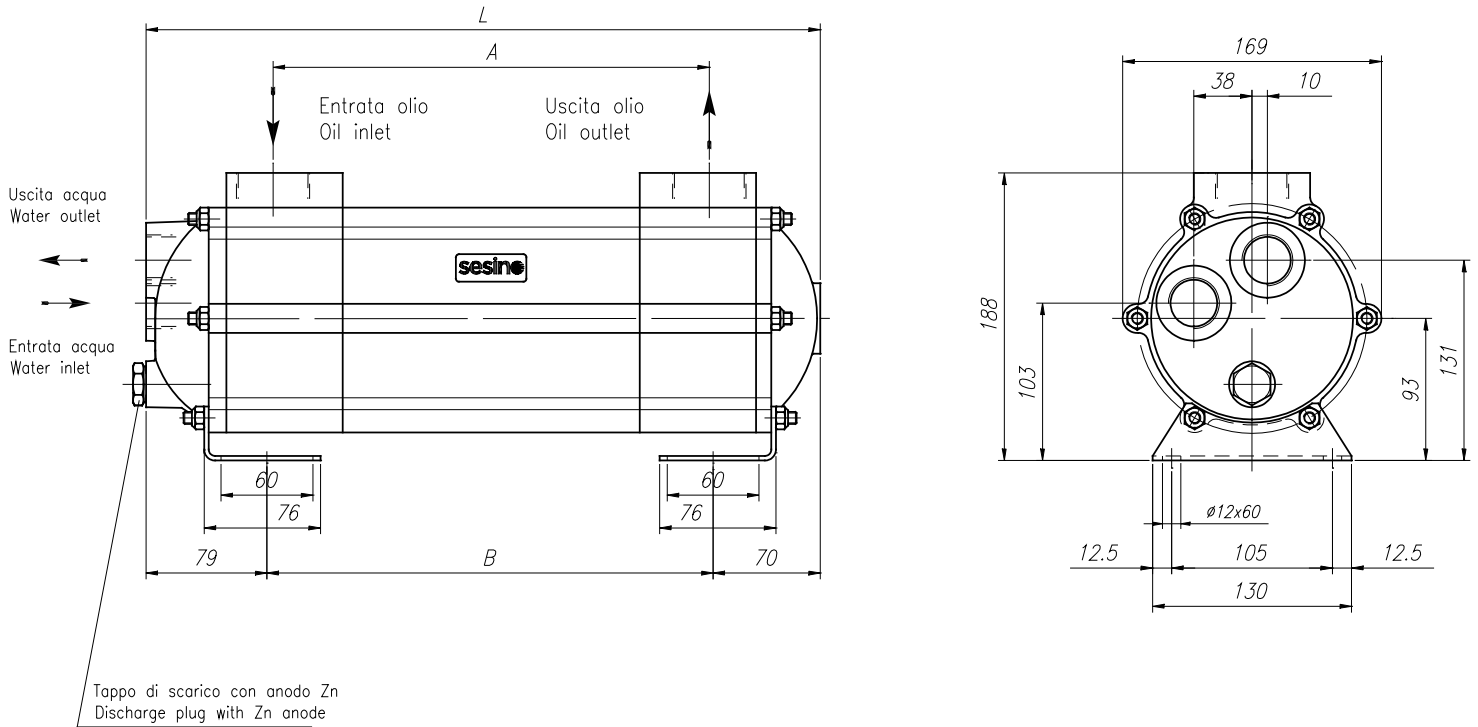

Static working pressure = 12 bar

Test pressure = 15 bar

Heat exchanged a $\Delta T_{in}=25^{\circ}C$ Potenza termica scambiata a $\Delta T_{in}=25^{\circ}C$ [kW]

Connections Connessioni

Type Tipo	Code Codice	Water flow Portata acqua [l/min]	Oil flow Portata olio [l/min]	min. water, min. oil flow min. acqua, min. olio	min. water, max. oil flow min. acqua, max. olio	max. water, min. oil flow max. acqua, min. olio	max. water, max. oil flow max. acqua, max. olio	Water Acqua	Oil Olio	Oil connections distance Interasse connessioni olio A [mm]	Anchor point distance Interasse fori fissaggio B [mm]	Length Lunghezza L [mm]	Weight Peso [kg]
MSG 134 P1	2SCG134P1	15-60	30-100	4,4	9,9	4,4	13,2	G1	G1-½	285	291,5	440,5	16,4
MSG 134 P2	2SCG134P2	15-60	40-130	14,3	24,2	18,7	36,3	G1	G1-½	535	541,5	690,5	22,6
MSG 134 P3	2SCG134P3	15-60	120-250	22	27,5	31,9	42,9	G1	G2	520	541,5	690,5	23
MSG 134 P4	2SCG134P4	15-60	80-250	9,35	23,1	9,9	31,9	G1	G1-½	845	851,5	1000,5	30,7
MSG 134 P5	2SCG134P5	15-60	200-400	34,1	42,9	52,8	77	G1	G2	830	851,5	1000,5	30,9
MSG 134 P6	2SCG134P6	15-60	30-170	12,1	28,6	13,2	39,6	G1	G1-½	1145	1151,5	1300,5	40
MSG 134 P7	2SCG134P7	15-60	200-500	35,2	70,4	45,1	104,5	G1	G2	1130	1151,5	1300,5	39,5

CONSTRUCTION MATERIALS

SHELL	TUBES	END COVERS
Aluminum*	COPPER*	Aluminum*

*standard

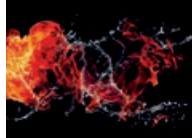

SHELL AND TUBE HEAT EXCHANGERS SCAMBIATORI ACQUA-OLIO A FASCIO TUBIERO



WATER FLOW RATE:

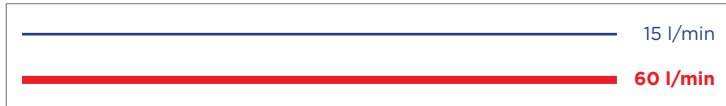

P1 P2 P3

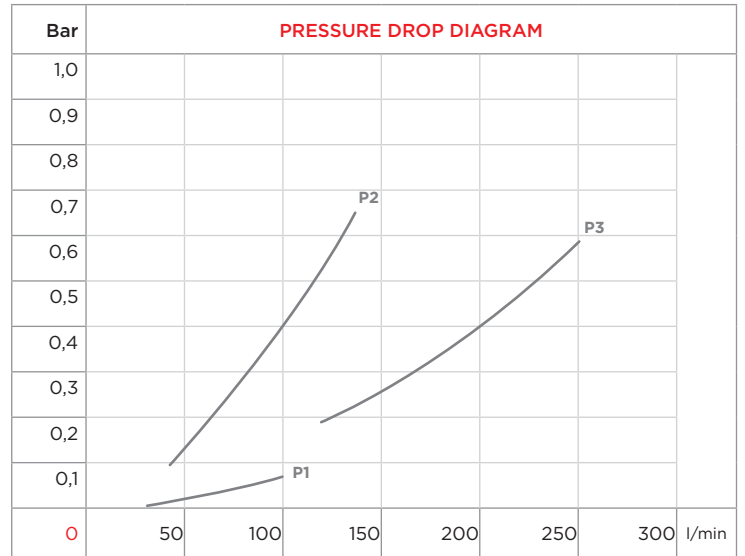
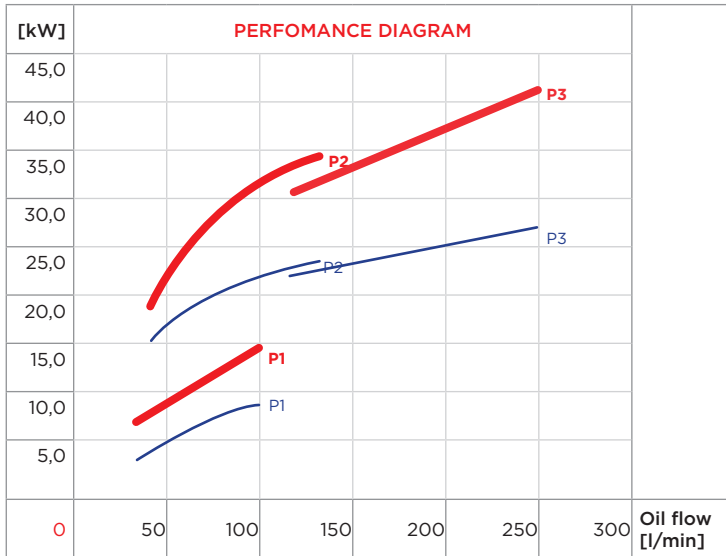

P4 P5 P6

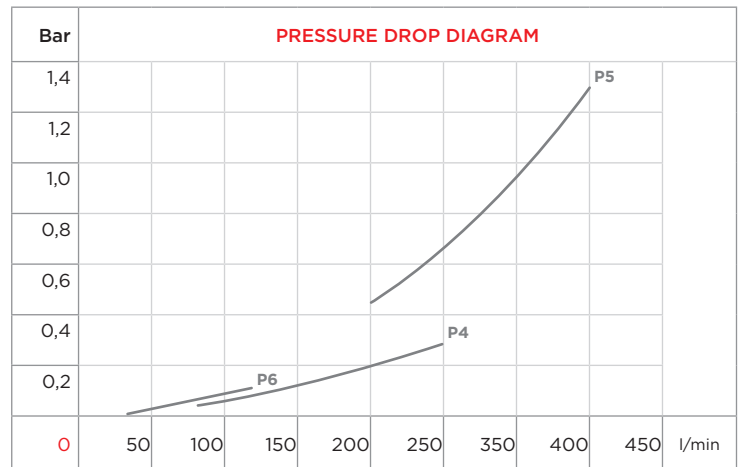
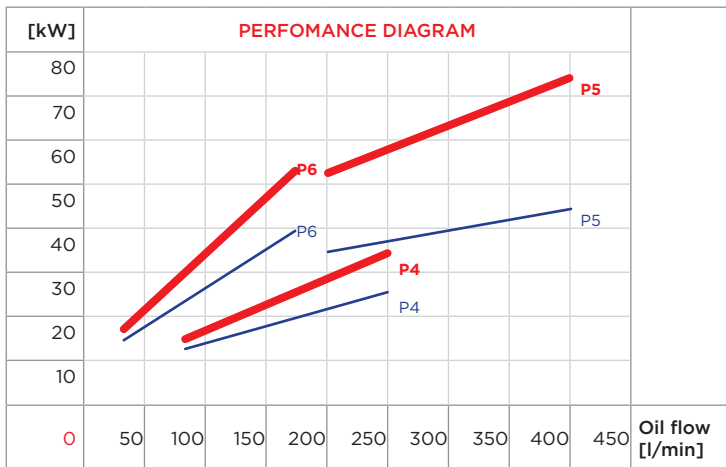

P7

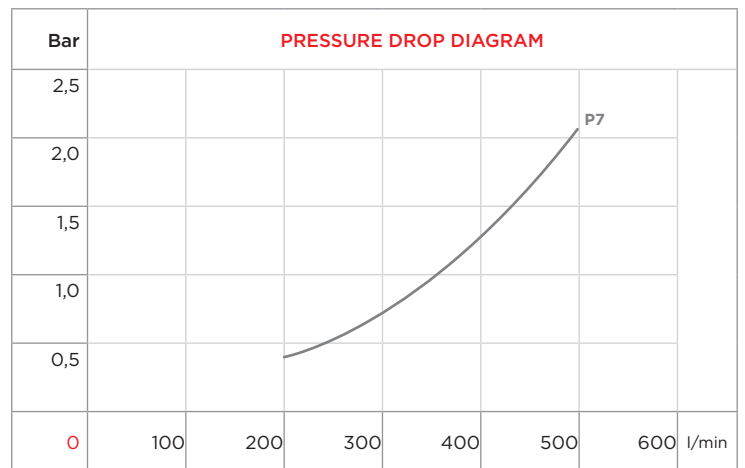
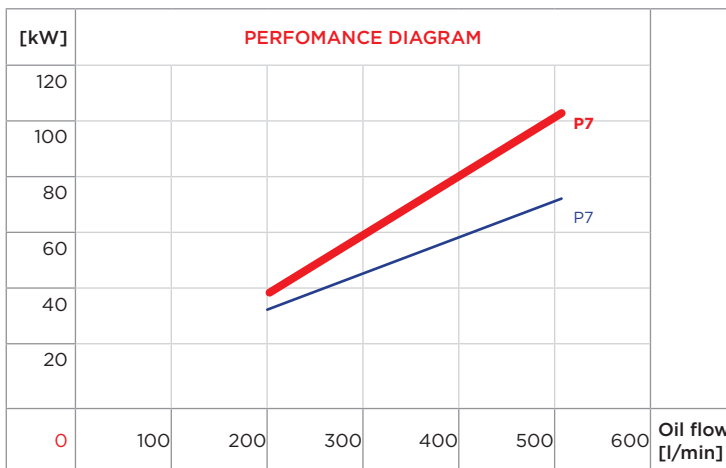

CORRECTION FACTOR								
ΔT_m	10	15	20	25	30	35	40	
f	2,5	1,67	1,25	1	0,83	0,71	0,63	

CORRECTION FACTOR								
cSt	22	30	46	68	100	150	220	
f	0,4	0,6	1	1,5	2,3	3,3	4,6	

MS 84 P INOX

- Dimensions and technical characteristics are not binding

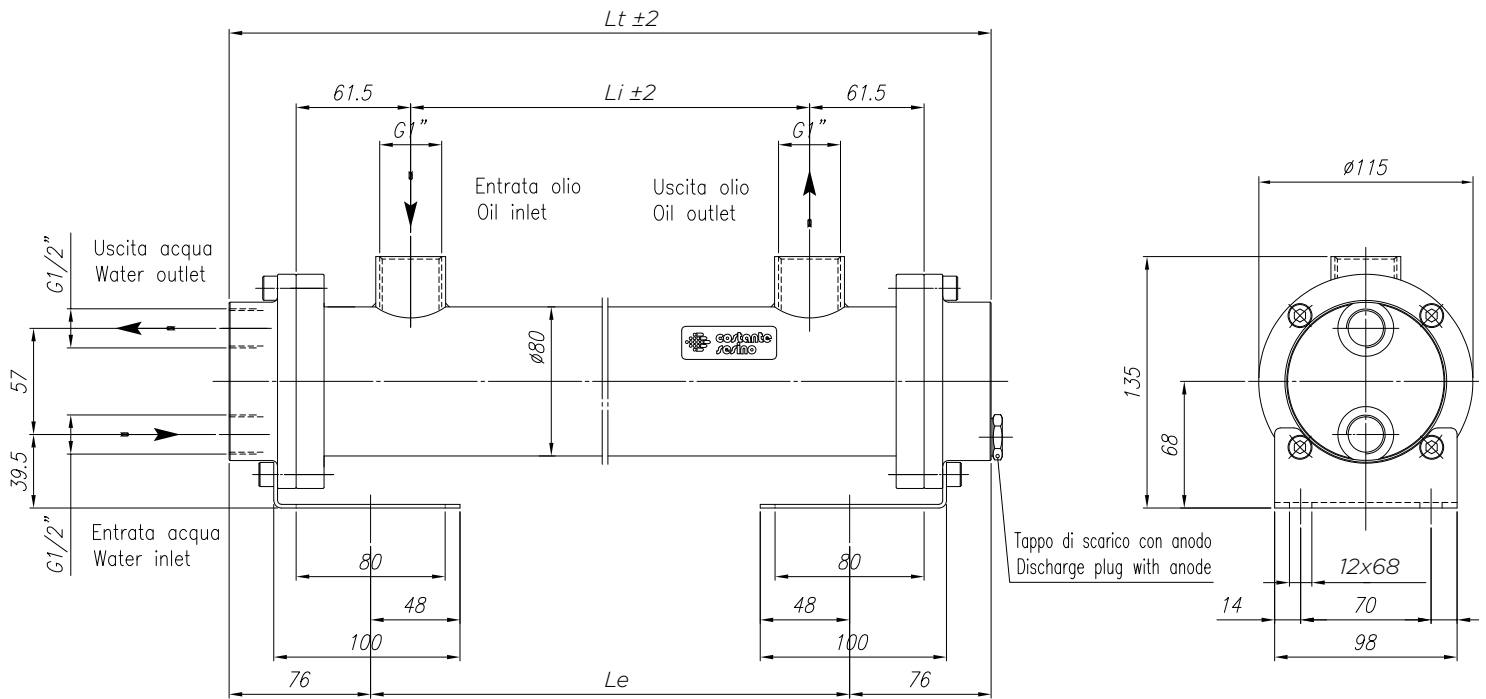

Static working pressure = 12 bar

Test pressure = 15 bar

TYPE	CODE	WATER FLOW l/min	OIL FLOW l/min	kW MIN water flow		kW MAX water flow		WEIGHT kg	DIMENSIONS			
				ΔT_m 25° C	ΔT_m 25° C	ΔT_m 25° C	ΔT_m 25° C		F	Li	Le	Lt
MS 84 P1	2SC84P1	7.5 - 30	30-80	2	3	2.6	4.2	4.5	1" gas	150	125-261	345
MS 84 P2	2SC84P2	7.5 - 30	20-60	2.6	4	3.25	5.6	6.3	1" gas	310	285-421	505
MS 84 P3	2SC84P3	7.5 - 30	50-100	3.6	4.4	4.6	8	6.5	1 1/2" gas	310	285-421	505
MS 84 P4	2SC84P4	7.5 - 30	30-80	4.8	7	6	10	9.0	1" gas	560	535-671	755
MS 84 P5	2SC84P5	7.5 - 30	80-130	6	7	7	9	9.0	1 1/2" gas	560	535-671	755
MS 84 P6	2SC84P6	7.5 - 30	40-90	9	12	12	18	10.8	1 1/2" gas	715	690-826	910
MS 84 P7	2SC84P7	7.5 - 30	100-160	11	14	15	21	10.8	1 1/2" gas	715	690-826	910
MS 84 P8	2SC84P8	7.5 - 30	60-110	12	16	16	24	12.3	1 1/2" gas	870	845-941	1065
MS 84 P9	2SC84P9	7.5 - 30	140-190	15	17	21	27	12.3	1 1/2" gas	870	845-941	1065

CONSTRUCTION MATERIALS

SHELL	TUBES	END COVERS
STAINLESS STEEL AISI 304	STAINLESS STEEL AISI 304	STAINLESS STEEL AISI 304

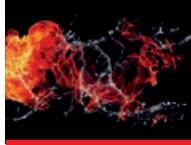

SHELL AND TUBE HEAT EXCHANGERS

SCAMBIATORI ACQUA-OLIO A FASCIO TUBIERO

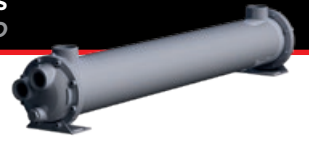

WATER FLOW RATE:



P1 P2 P3

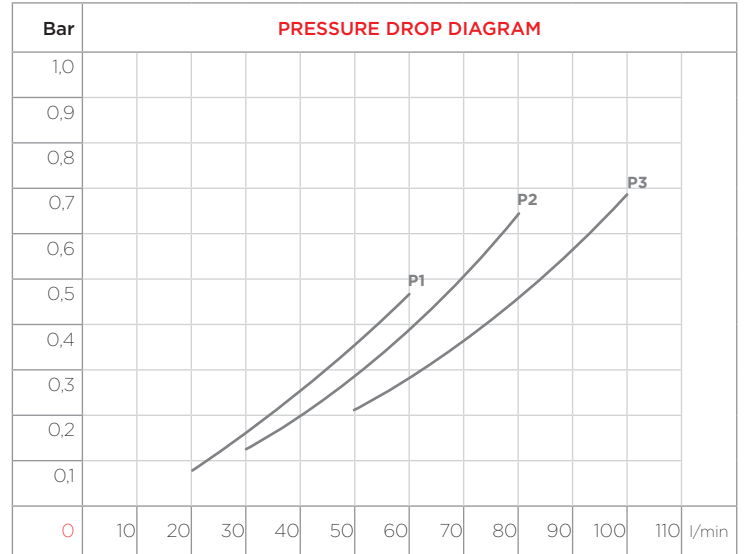
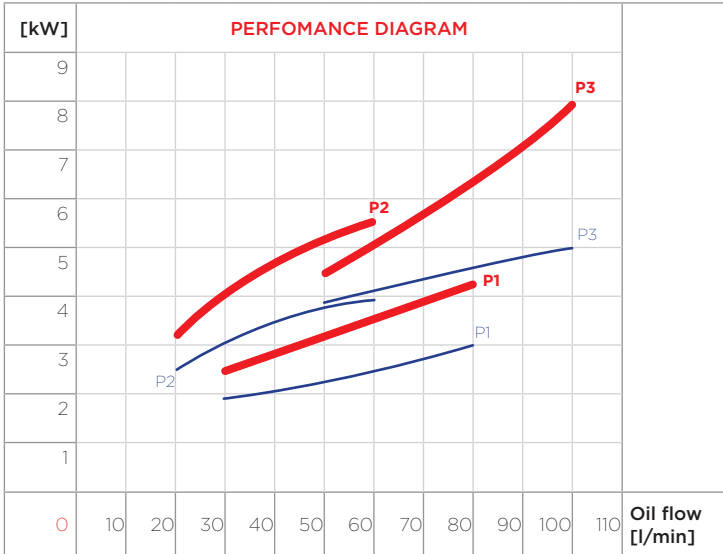

P4 P5 P6

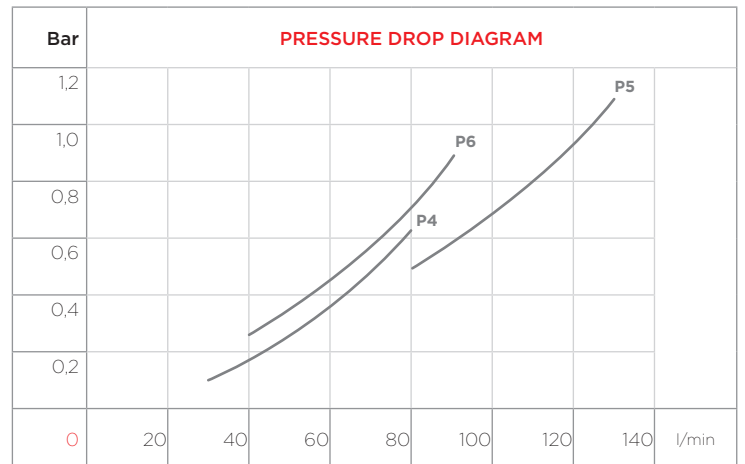
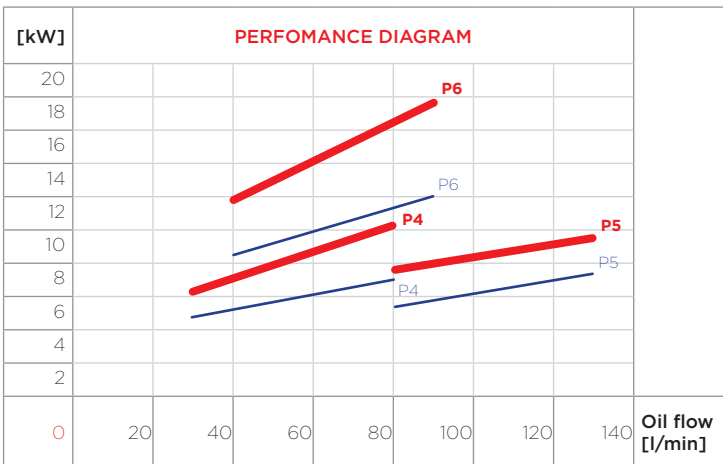

P7 P8 P9

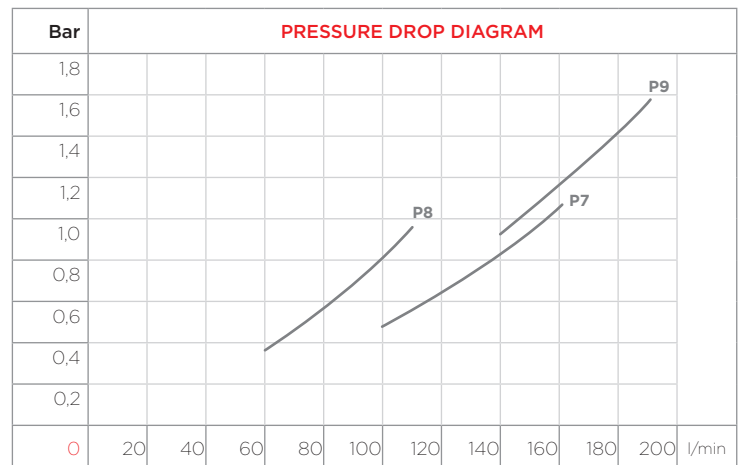
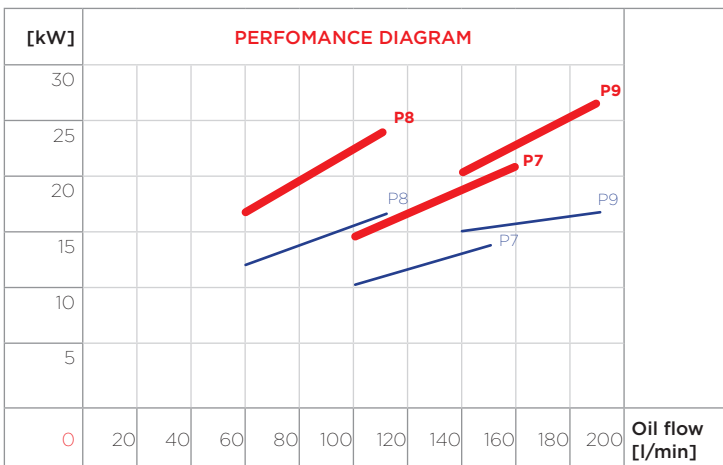

CORRECTION FACTOR							
ΔT_m	10	15	20	25	30	35	40
f	2,5	1,67	1,25	1	0,83	0,71	0,63

CORRECTION FACTOR							
cSt	22	30	46	68	100	150	220
f	0,4	0,6	1	1,5	2,3	3,3	4,6



MS 134 P INOX e CuNi

- Dimensions and technical characteristics are not binding

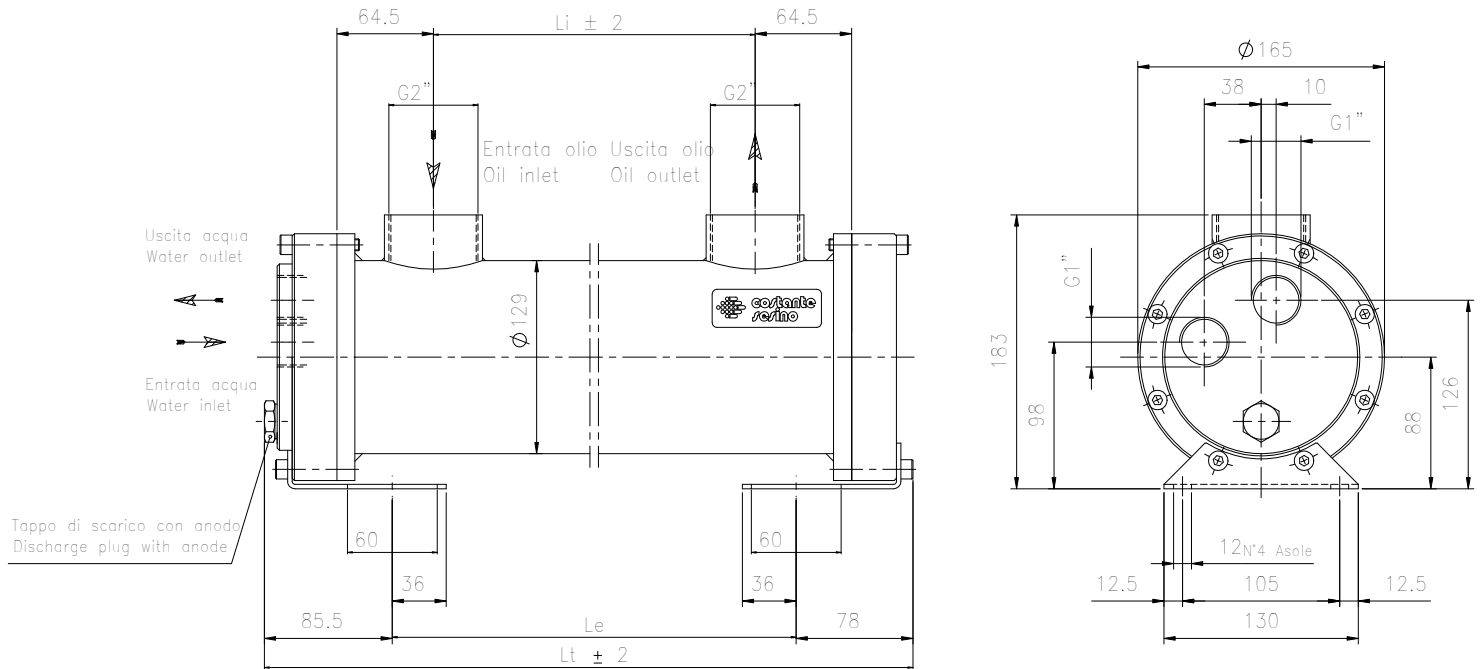

Static working pressure = 12 bar

Test pressure = 15 bar

TYPE	CODE	OIL FLOW	WATERFLOW	kW MIN water flow		kW MAX water flow		WEIGHT	DIMENSIONS			
				l/min	l/min	ΔTm 25° C	ΔTm 25° C		kg	F	Li	Le
MS 134 P1	2SC134P1	30-100	15-60	3,66	8,63	3,8	11,5	16,4	1 1/2" gas	285	277-373	488
MS 134 P2	2SC134P2	40-130	15-60	13	22	17	33	22,6	1 1/2" gas	535	527-623	738
MS 134 P3	2SC134P3	120-250	15-60	20	25	29	39	23,0	2" gas	520	527-623	738
MS 134 P4	2SC134P4	80-250	15-60	8,5	21	9	29	30,7	1 1/2" gas	845	837-933	1048
MS 134 P5	2SC134P5	200-400	15-60	31	39	48	70	30,9	2" gas	830	837-933	1048
MS 134 P6	2SC134P6	30-170	15-60	11	26	12	36	40,0	1 1/2" gas	1145	1137-1233	1348
MS 134 P7	2SC134P7	200-500	15-60	32	64	41	95	39,5	2" gas	1130	1137-1233	1348

CONSTRUCTION MATERIALS

SHELL	TUBES	END COVERS
STAINLESS STEEL AISI 304	STAINLESS STEEL AISI 304	STAINLESS STEEL AISI 304
CARBON STEEL	CuNi (marine use)	BRONZE

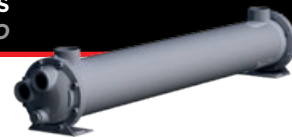
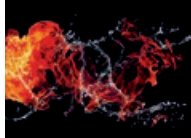

WATER FLOW RATE:

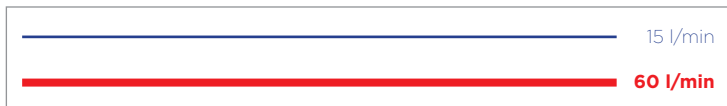

P1 P2 P3

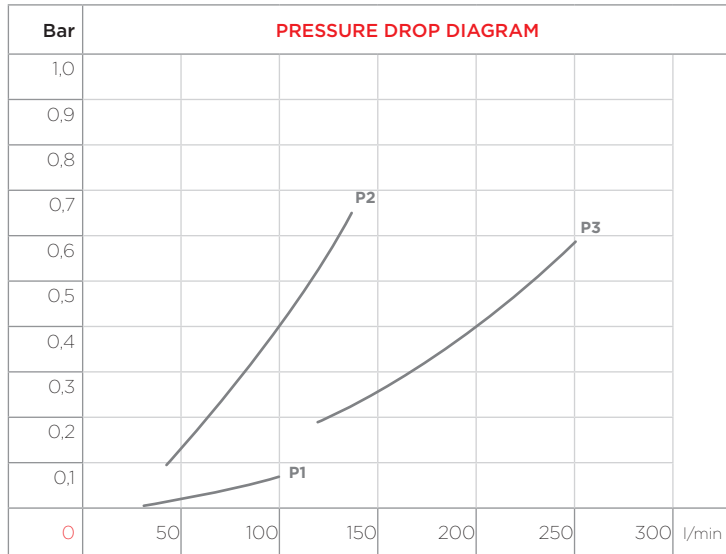
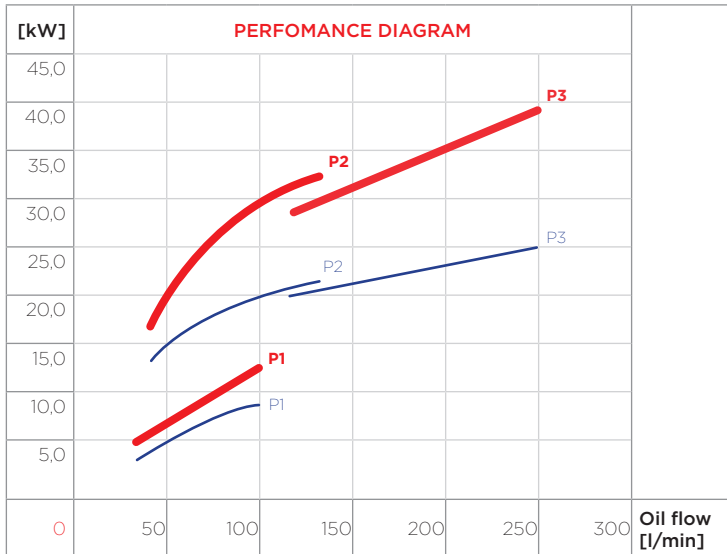

P4 P5 P6

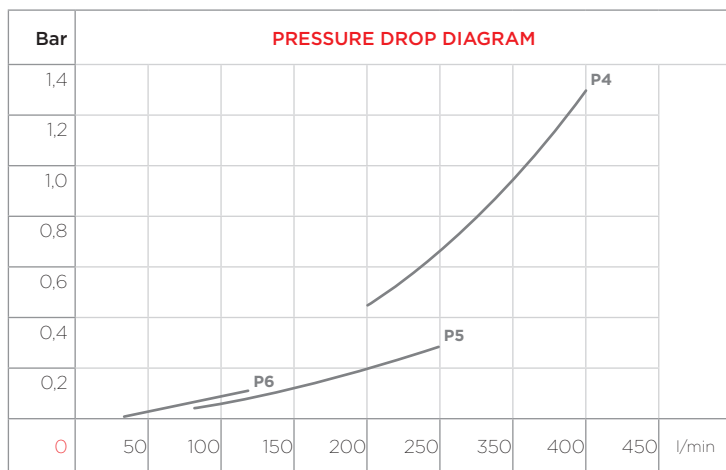
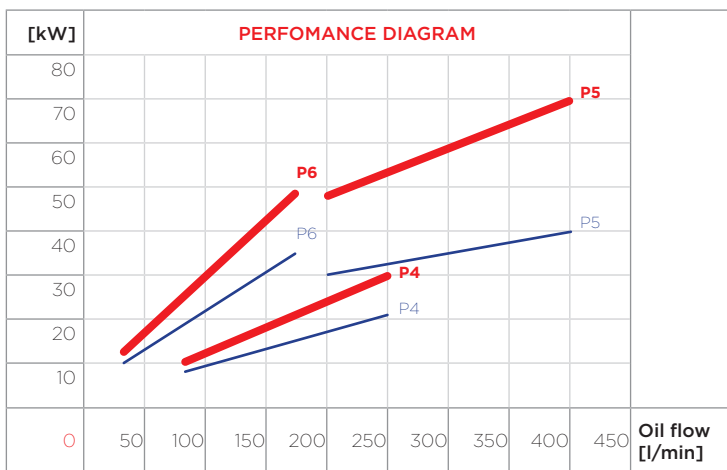

P7

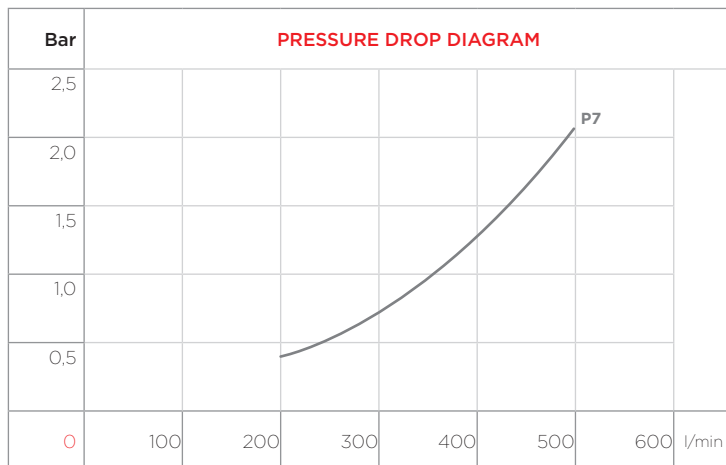
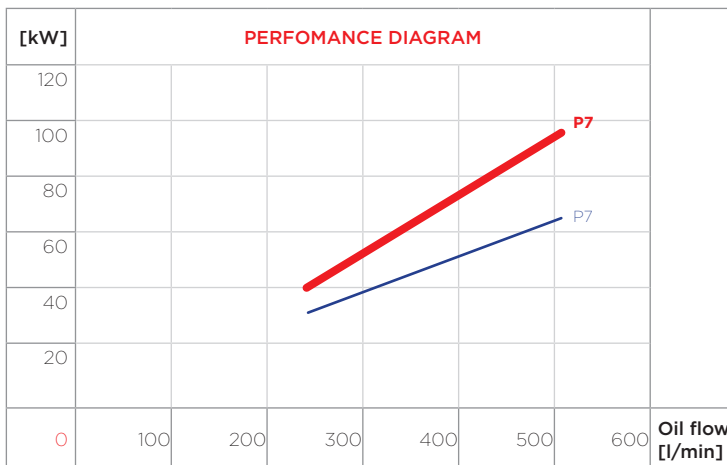

CORRECTION FACTOR								
ΔT_m	10	15	20	25	30	35	40	
f	2,5	1,67	1,25	1	0,83	0,71	0,63	

CORRECTION FACTOR								
cSt	22	30	46	68	100	150	220	
f	0,4	0,6	1	1,5	2,3	3,3	4,6	

MS 84/2B MARINE USE

- Dimensions and technical characteristics are not binding

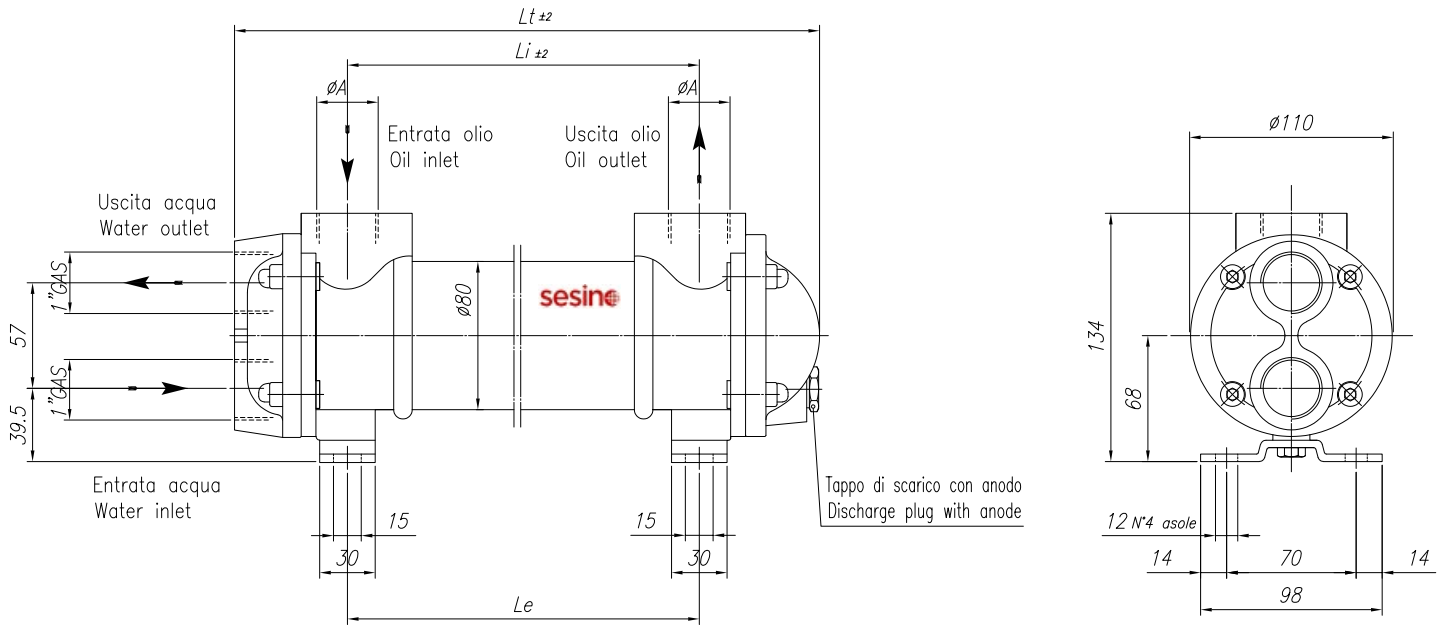

Static working pressure = 12 bar

Test pressure = 15 bar

TYPE	OIL FLOW l/min	kW dissipated with oil Oil=50°C, 46cSt, H2O=15°C	WEIGHT kg	DIMENSIONS			
				ϕA	Li	Le	Lt
MS 84/2 B1	30-80	4-4,5	4,5	1" gas	150	150	273
MS 84/2 B2	20-60	7-8,0	6,3	1" gas	310	310	433
MS 84/2 B3	50-100	7-8,0	6,5	1 1/2" gas	310	327	451
MS 84/2 B4	30-80	14-16,0	9,0	1" gas	560	560	683
MS 84/2 B5	80-130	14-16,0	9,0	1 1/2" gas	560	577	701
MS 84/2 B6	40-90	17-20,0	10,8	1 1/2" gas	715	732	856
MS 84/2 B7	100-160	17-20,0	10,8	1 1/2" gas	715	732	856
MS 84/2 B8	60-110	20-23,0	12,3	1 1/2" gas	870	887	1011
MS 84/2 B9	140-190	20-23,0	12,3	1 1/2" gas	870	887	1011

CONSTRUCTION MATERIALS

SHELL	TUBES	END COVERS
CARBON STEEL	CuNi (marine use)	BRONZE

*standard

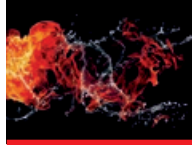

SHELL AND TUBE HEAT EXCHANGERS

SCAMBIATORI ACQUA-OLIO A FASCIO TUBIERO



WATER FLOW RATE:



B1 B2 B3

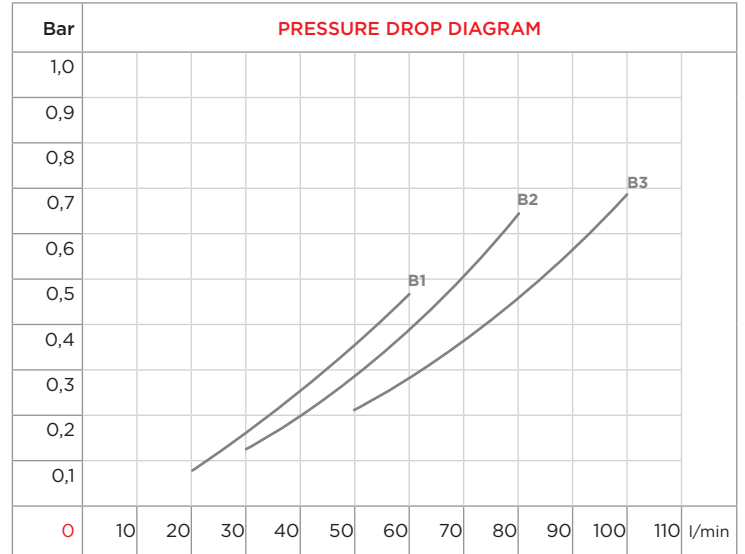
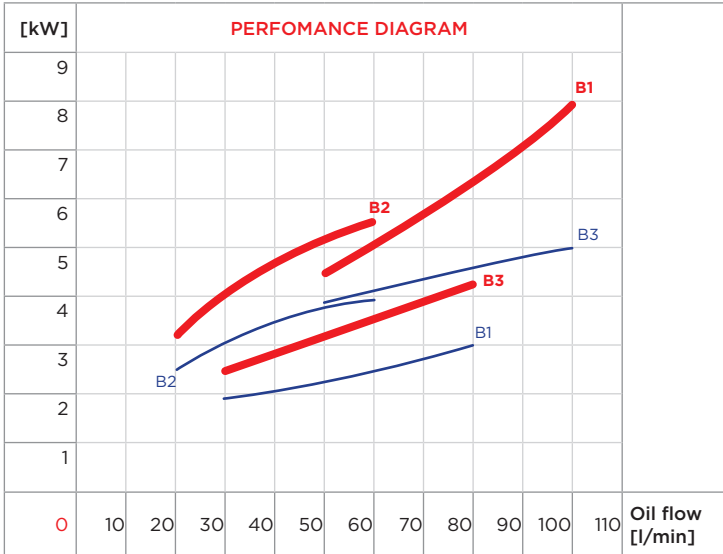

B4 B5 B6

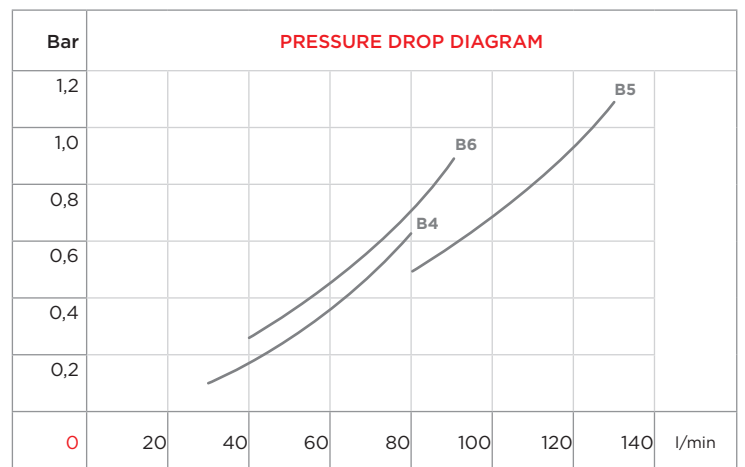
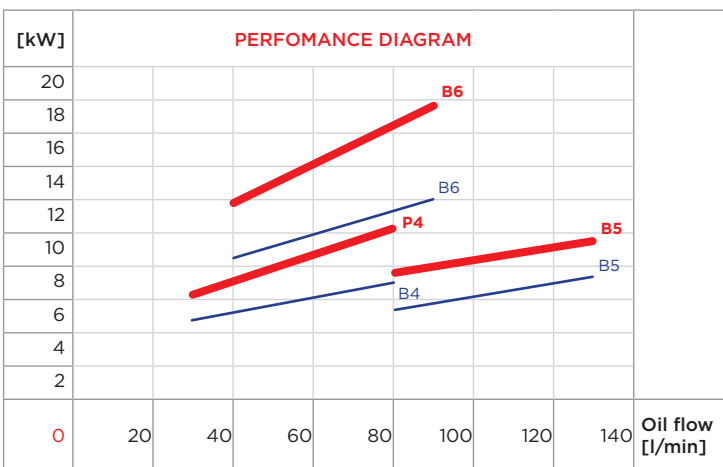

B7 B8 B9

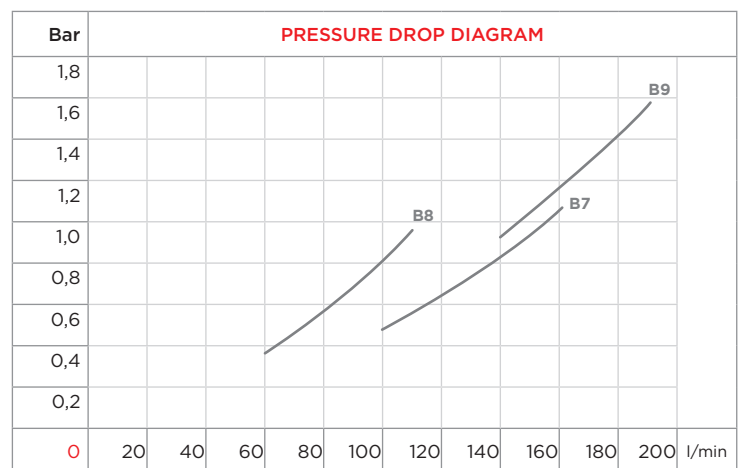
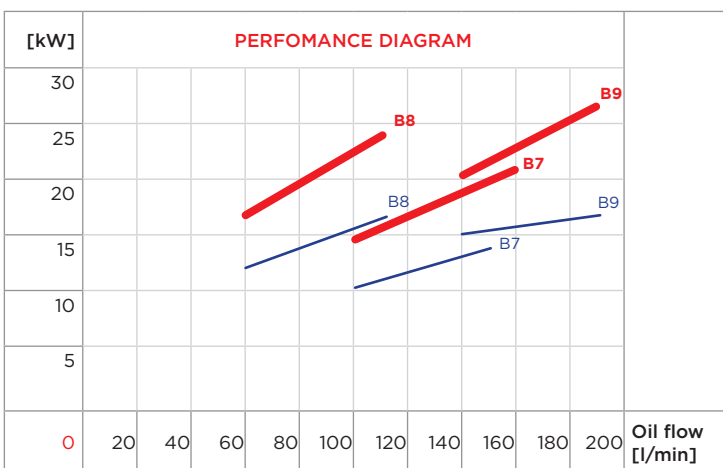

CORRECTION FACTOR							
ΔT_m	10	15	20	25	30	35	40
f	2,5	1,67	1,25	1	0,83	0,71	0,63

CORRECTION FACTOR							
cSt	22	30	46	68	100	150	220
f	0,4	0,6	1	1,5	2,3	3,3	4,6

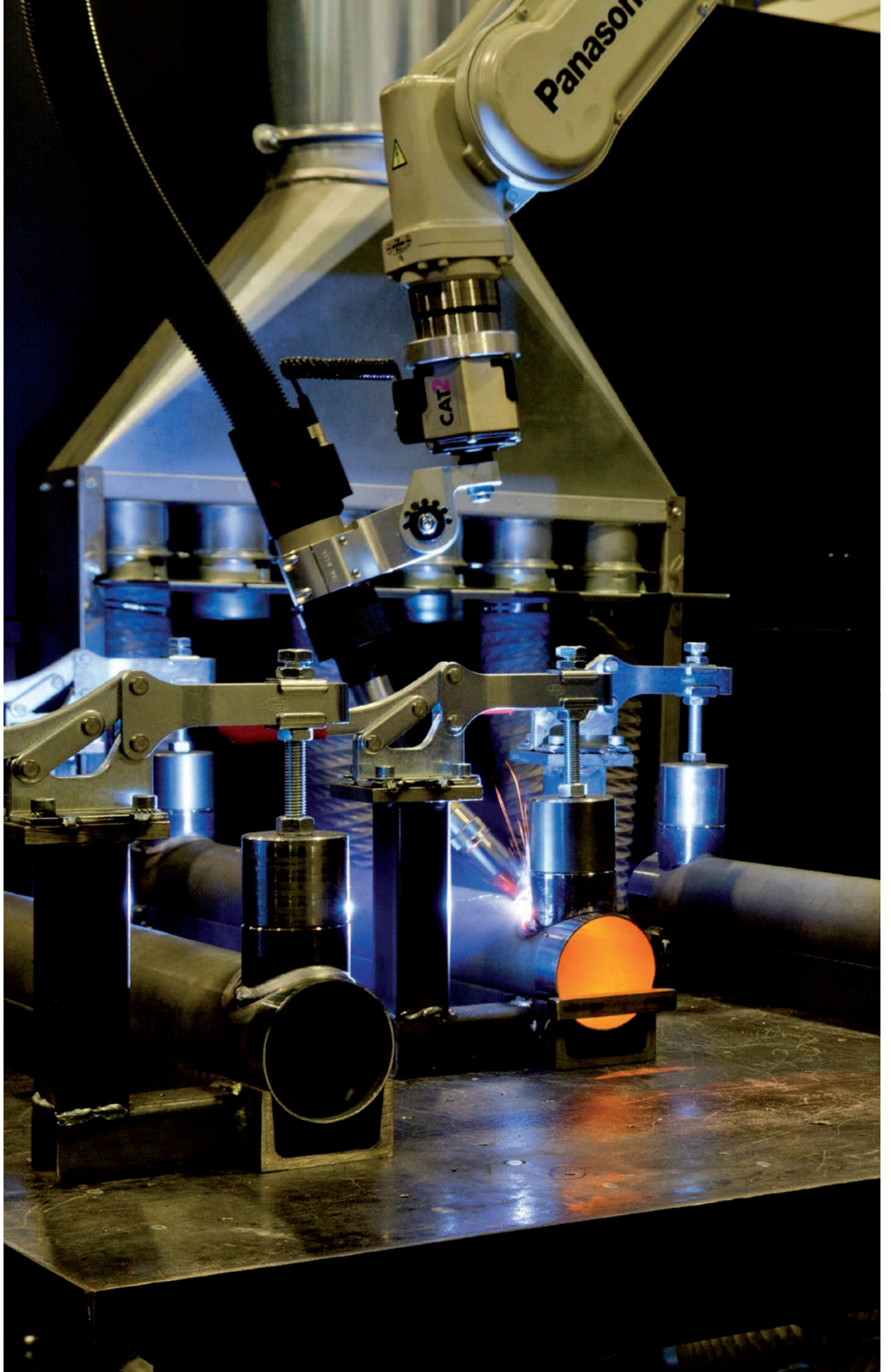

WATER-OIL HEAT EXCHANGERS WITH REMOVABLE TUBE BUNDLE

SCAMBIATORI DI CALORE ACQUA-OLIO A FASCIO TUBIERO ESTRAIBILE

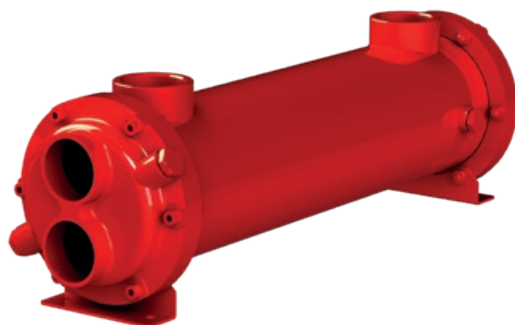

WATER-OIL HEAT EXCHANGERS WITH REMOVABLE TUBE BUNDLE SERIES MS 152, MS 172, MS 202, MS 272, and MS 352

These series of heat exchangers feature a removable tube bundle, allowing inspection of both the oil and water sides. This makes them suitable for use with unfiltered liquids as well.

The tube bundle can be made of: Copper, for use with fresh water; Cupronickel, for seawater applications; Stainless steel, for corrosive fluids and gas.

The heat exchangers are built with small-diameter smooth tubes, achieving the best compromise between high thermal efficiency and low pressure drops.

The oil flow rates shown in the tables are the recommended values for proper exchanger operation. Operating below the minimum recommended flow rate results in low oil velocity and a significant drop in performance.

Operating above the maximum recommended flow rate causes high pressure losses, without a meaningful increase in thermal efficiency.

The maximum allowable working pressure for both circuits is 12 bar.

For accurate sizing of tube bundle exchangers, we provide a calculation software. By simply entering a few parameters, the appropriate exchanger can be selected and all operating data obtained in a technical data sheet.

Tube bundle exchangers can also be used with other types of fluids, provided they are compatible with copper and its alloys. However, for any application other than oil cooling, we recommend consulting our Technical Department.

Heat exchange surfaces available: from 1 to 30 m².

SCAMBIATORI ACQUA-OLIO A FASCIO TUBIERO ESTRAIBILE SERIE MS 152, MS 172, MS 202, MS 272 e MS 352

Queste serie di scambiatori hanno il fascio tubiero smontabile che è pertanto ispezionabile sia lato olio che lato acqua, ciò li rende idonei all'impiego anche con liquidi non filtrati.

Il materiale di costruzione del fascio tubiero può essere Rame, per utilizzo con acqua dolce, cupronickel, per utilizzo con acqua di mare, acciaio inossidabile, per impieghi con fluidi corrosivi e gas.

Sono costruiti con tubi lisci di piccolo diametro, raggiungendo in questo modo il miglior compromesso tra elevata resa termica e basse perdite di carico.

Le portate olio indicate in tabella sono quelle consigliate per il buon funzionamento dello scambiatore. Andando al di sotto della portata minima indicata, la bassa velocità dell'olio causa un forte calo di rendimento, mentre una portata superiore alla massima causa perdite di carico notevoli, senza peraltro aumentare la resa termica in maniera apprezzabile.

La pressione di esercizio massima ammessa in entrambe i circuiti è 12 bar.

Per il calcolo esatto degli scambiatori a fascio tubiero possiamo fornire un programma di calcolo; mediante il semplice inserimento di alcuni dati è possibile stabilire lo scambiatore necessario e ottenere tutti i parametri di funzionamento su un data-sheet.

Gli scambiatori a fascio tubiero possono essere utilizzati con altri tipi di fluidi, a condizione che essi siano compatibili con il rame e le sue leghe. Consigliamo comunque, per qualsiasi impiego che non sia il raffreddamento dell'olio, di consultare il nostro Ufficio Tecnico.

Superfici di scambio da 1 a 30 m²

Selection procedure

The curves are based on the following data:

- 1) Oil viscosity ISO VG 46
- 2) Arithmetic mean temperature between oil and water 25 [°C] (ΔT_m)

If your application parameters are different, follow these steps:

- 1) Define the arithmetic mean temperature [see the technical example on page 7] and select the correction factor from the table

CORRECTION FACTOR							
ΔT_m	10	15	20	25	30	35	40
f	2,5	1,67	1,25	1	0,83	0,71	0,63

- 2) Calculate the adjusted thermal power $\dot{Q}_d = \dot{Q} \cdot F$

- 3) Select the model from the curve
Cross-check on the diagram the values of the oil flow, of the water flow and of the thermal power.

Procedura di selezione dello scambiatore

Le curve riportate sono basate sulle seguenti assunzioni:

- 1) Viscosità cinematica dell'olio pari a 46 [cSt]
- 2) Temperatura media aritmetica tra i due fluidi pari a 25 [°C] (ΔT_m)

Se si ha una temperatura media aritmetica differente da 25 [°C], seguire la procedura sottostante:

- 1) Determinare la temperatura media aritmetica tra i due fluidi [vedere esempio a pagina 9 per effettuare il calcolo] e selezionare il fattore di correzione appropriato dalla tabella

CORRECTION FACTOR							
ΔT_m	10	15	20	25	30	35	40
f	2,5	1,67	1,25	1	0,83	0,71	0,63

- 2) Determinare la potenza termica da smaltire opportunamente corretta $\dot{Q}_d = \dot{Q} \cdot F$

- 3) Selezionare il modello
Incrociare i valori di portata volumetrica d'olio, d'acqua e della potenza termica corretta sull'apposito grafico

MS 152/7 P

- Dimensions and technical characteristics are not binding

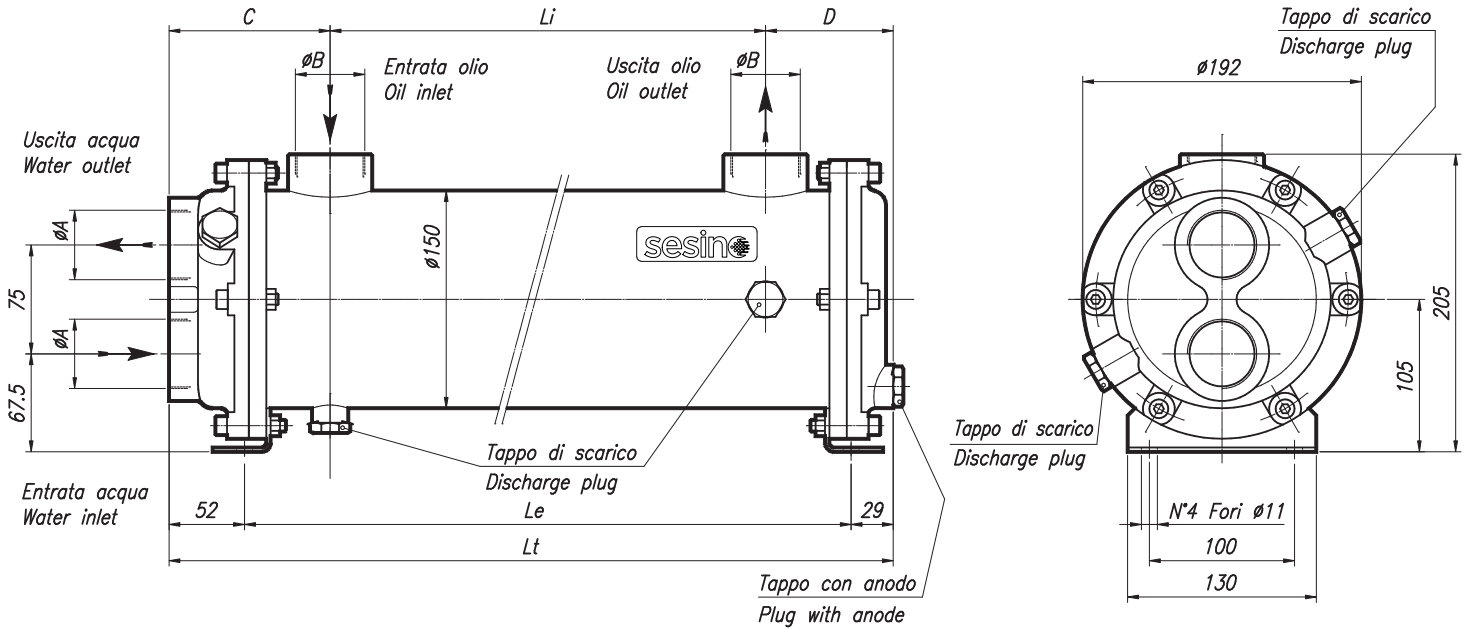

Static working pressure = 12 bar

Test pressure = 15 bar

TYPE	CODE	WATER FLOW		OIL FLOW		kW MIN water flow		kW MAX water flow		WEIGHT	DIMENSIONS				
		l/min	l/min	l/min	l/min	ΔTm 25° C	ΔTm 25° C	kg	ϕA		ϕB	C	D	Li	Le
MS 152/7 P1	2SC152/7P1	40-120	40-160	4,5	6,9	5,1	8,3	17	1" gas	3/4" gas	101	78	80	178	259
MS 152/7 P2	2SC152/7P2	80-200	40-160	8	10	10	15	21	1" gas	1" gas	111	88	150	268	349
MS 152/7 P3	2SC152/7P3	130-300	40-160	15	19	23	33	26,5	1 1/2" gas	1 1/2" gas	111	88	300	418	499
MS 152/7 P4	2SC152/7P4	150-330	40-160	16	29	21	41	32	2" gas	2" gas	121	98	430	568	649
MS 152/7 P5	2SC152/7P5	200-400	40-160	34	42	55	71	38,5	2" gas	2" gas	121	98	590	728	809
MS 152/7 P6	2SC152/7P6	100-300	40-160	21	42	35	65	44	2" gas	2" gas	121	98	720	858	939
MS 152/7 P7	2SC152/7P7	200-500	40-160	39	47	69	98	54	2" gas	2" gas	121	98	970	1108	1189
MS 152/7 P8	2SC152/7P8	200-500	40-160	48	55	88	118	62	2" gas	2" gas	121	98	1170	1308	1389
MS 152/7 P9	2SC152/7P9	200-500	40-160	55	70	97	130	70	2" gas	2" gas	121	98	1370	1508	1589

CONSTRUCTION MATERIALS

SHELL	TUBES	END COVERS
CARBON STEEL*	COPPER*	CAST IRON*
STAINLESS STEEL AISI 304	STAINLESS STEEL AISI 304	STAINLESS STEEL AISI 304
CARBON STEEL	CuNi (water sea)	BRONZE

*standard

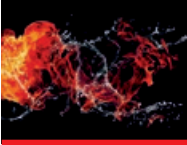

WATER-OIL HEAT EXCHANGERS WITH TUBE BUNDLE
SCAMBIATORI ACQUA-OLIO A FASCIO TUBIERO ESTRAIBILE



WATER FLOW RATE:

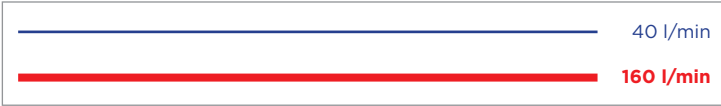

P1 P2 P3

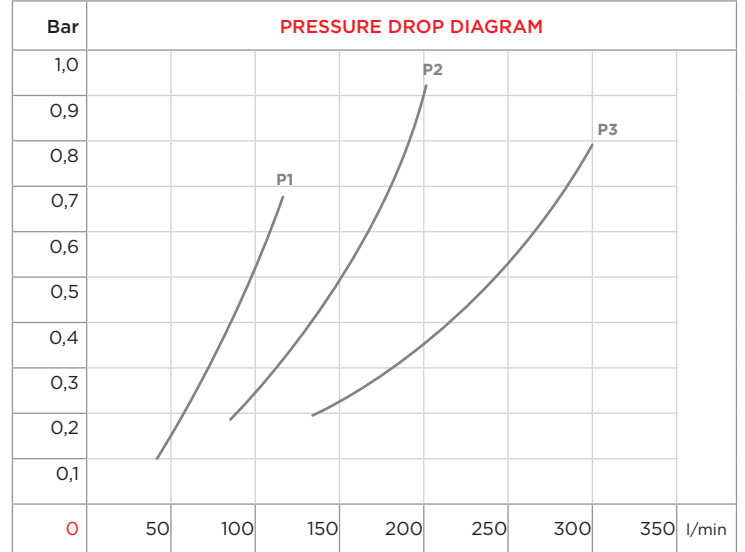
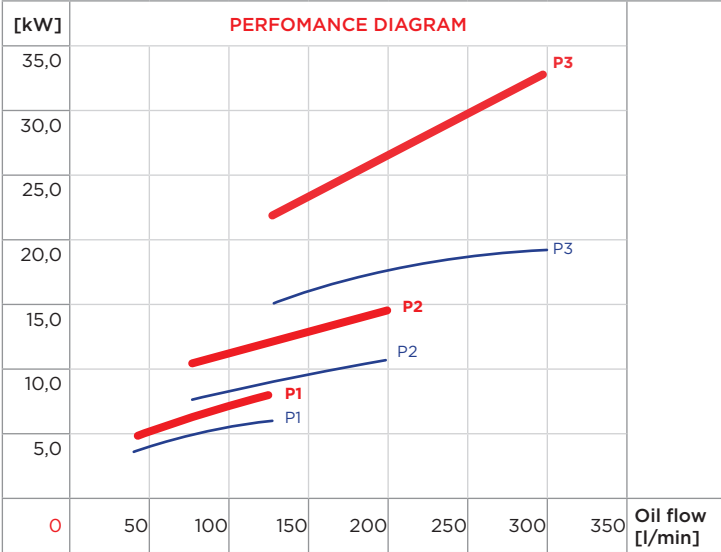

P4 P5 P6

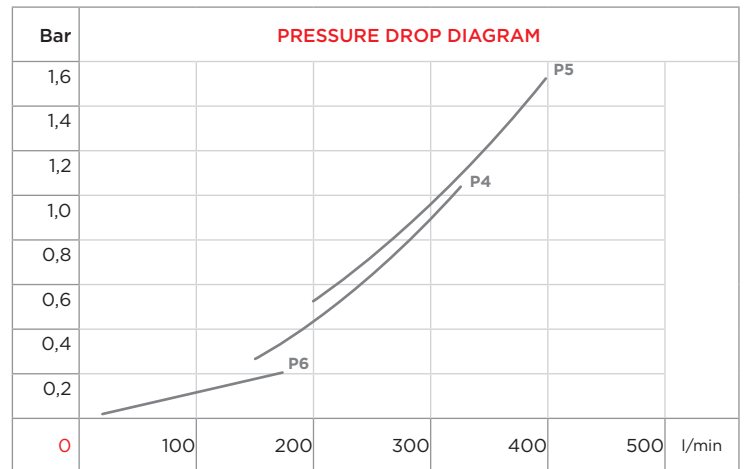
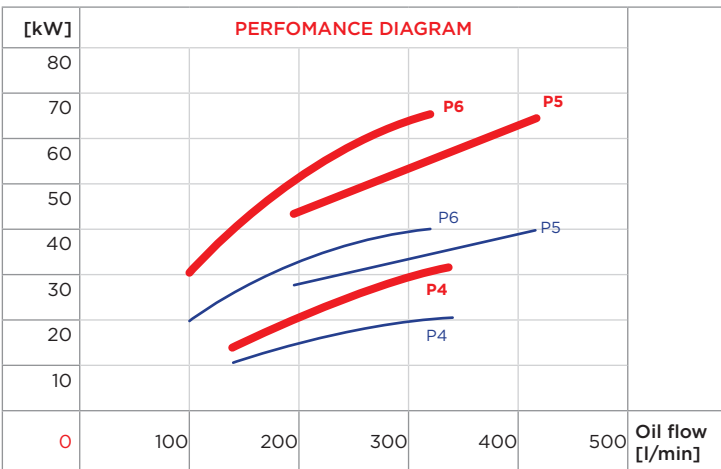

P7 P8 P9

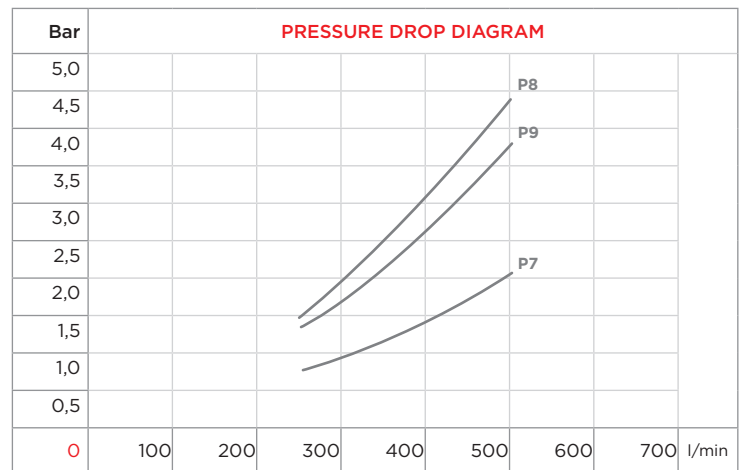
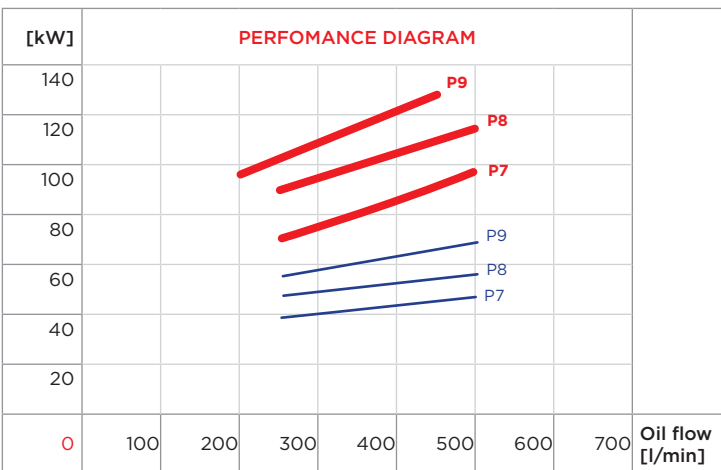

CORRECTION FACTOR							
ΔT_m	10	15	20	25	30	35	40
f	2,5	1,67	1,25	1	0,83	0,71	0,63

CORRECTION FACTOR							
cSt	22	30	46	68	100	150	220
f	0,4	0,6	1	1,5	2,3	3,3	4,6

MS 152/10 P

- Dimensions and technical characteristics are not binding

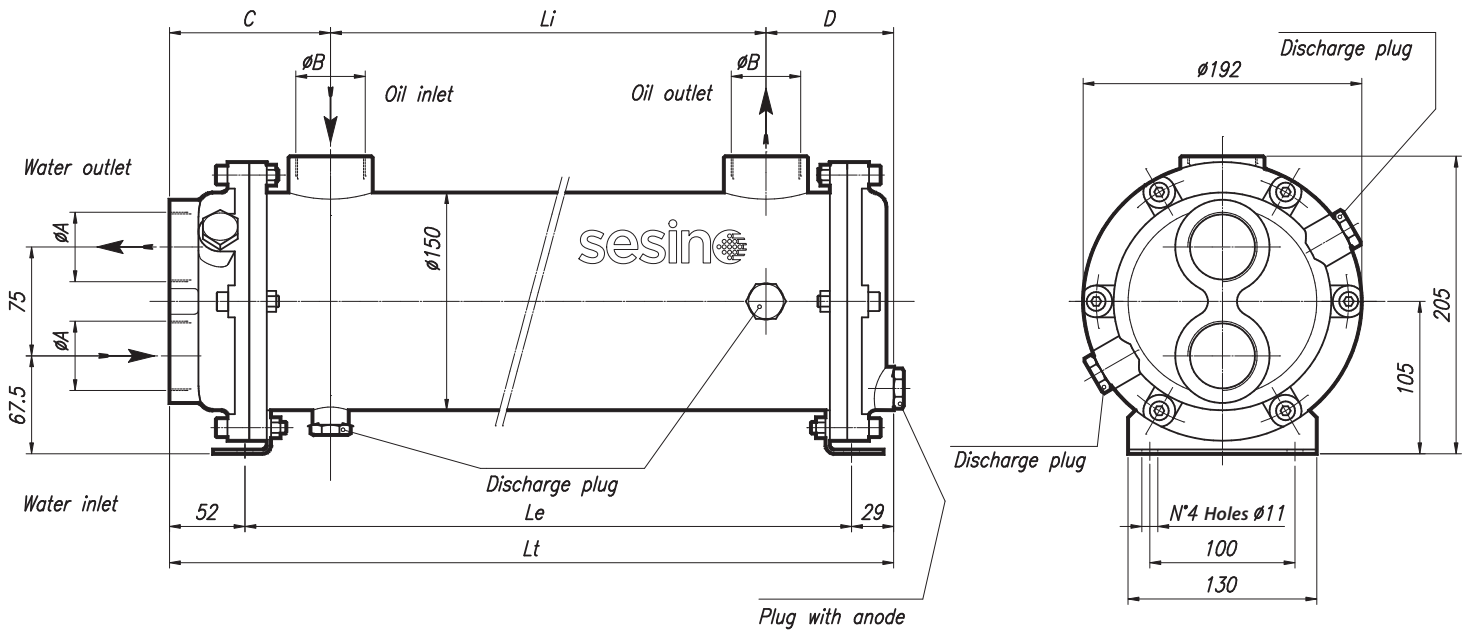

Static working pressure = 12 bar

Test pressure = 15 bar

TYPE	CODE	OIL FLOW l/min	WATER FLOW l/min	kW MIN water flow		kW MAX water flow		WEIGHT kg	DIMENSIONS						
				ΔT_m 25° C	ΔT_m 25° C	ΔT_m 25° C	ΔT_m 25° C		øA	øB	C	D	Li	Le	Lt
MS 152/10 P1	2SC152/10P1	30-150	40-160	2,1	3,5	2,5	4,5	16	1" gas	3/4" gas	101	78	80	178	259
MS 152/10 P2	2SC152/10P2	50-150	40-160	4	5	4,6	6	19	1" gas	1" gas	111	88	150	268	349
MS 152/10 P3	2SC152/10P3	60-250	40-160	7	10	8,5	14	24	1 1/2" gas	1 1/2" gas	111	88	300	418	499
MS 152/10 P4	2SC152/10P4	90-250	40-160	12	17	16	21	29	2" gas	2" gas	121	98	430	568	649
MS 152/10 P5	2SC152/10P5	150-280	40-160	15	20	21	30	34	2" gas	2" gas	121	98	590	728	809
MS 152/10 P6	2SC152/10P6	170-300	40-160	19	23	27	37	39	2" gas	2" gas	121	98	720	858	939
MS 152/10 P7	2SC152/10P7	100-180	40-160	15	19	31	42	47	2" gas	2" gas	121	98	858	1108	1189
MS 152/10 P8	2SC152/10P8	160-240	40-160	29	35	41	52	54	2" gas	2" gas	121	98	1108	1308	1389
MS 152/10 P9	2SC152/10P9	220-400	40-160	43	46	64	72	61	2" gas	2" gas	121	98	1308	1508	1589

CONSTRUCTION MATERIALS

SHELL	TUBES	END COVERS
CARBON STEEL*	COPPER*	CAST IRON*
STAINLESS STEEL AISI 304	STAINLESS STEEL AISI 304	STAINLESS STEEL AISI 304
CARBON STEEL	CuNi (water sea)	BRONZE

*standard

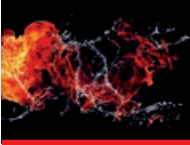

WATER-OIL HEAT EXCHANGERS WITH TUBE BUNDLE
SCAMBIATORI ACQUA-OLIO A FASCIO TUBIERO ESTRAIBILE



WATER FLOW RATE:

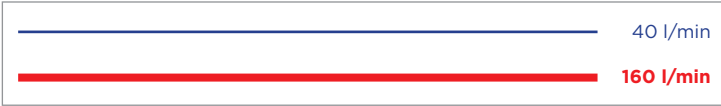

P1 P2 P3

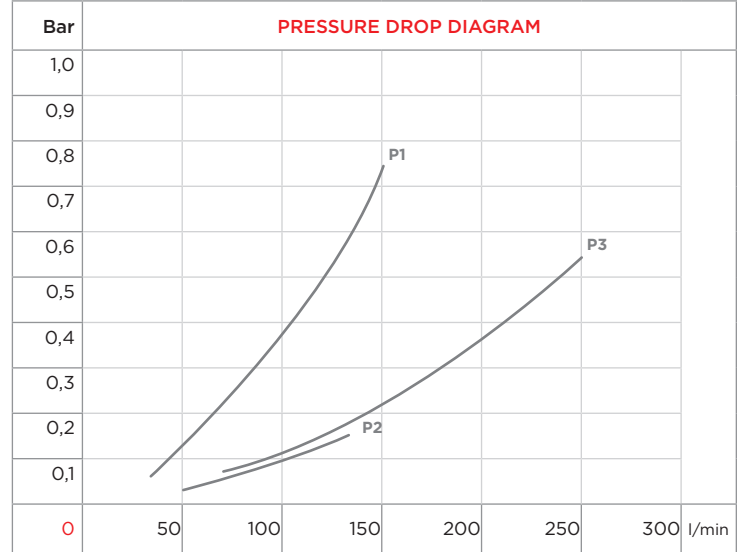
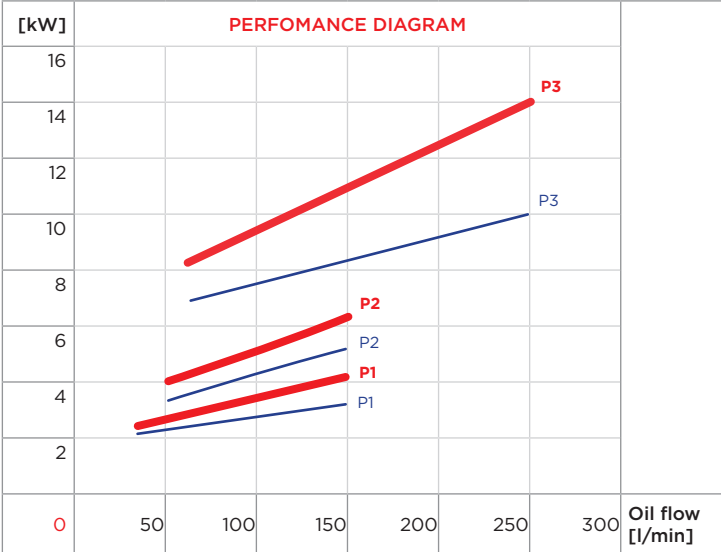

P4 P5 P6

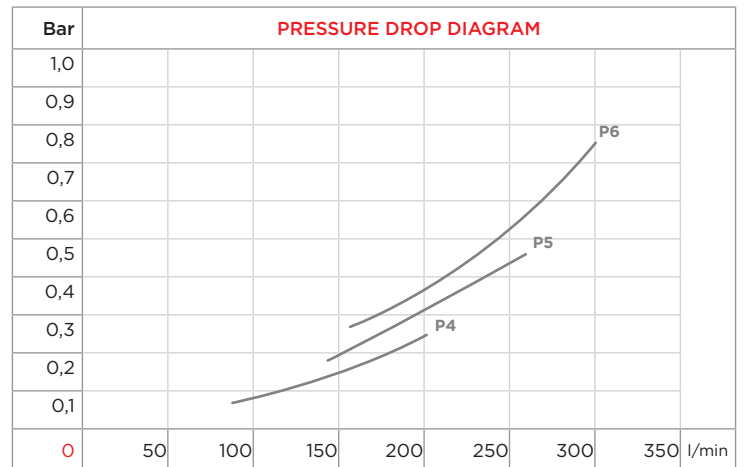
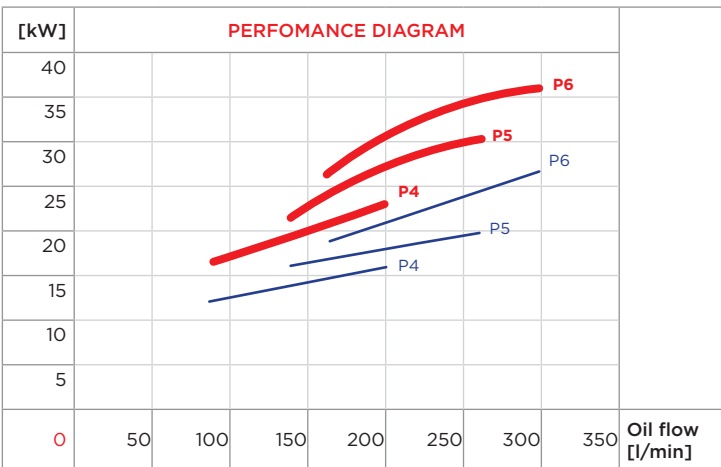

P7 P8 P9

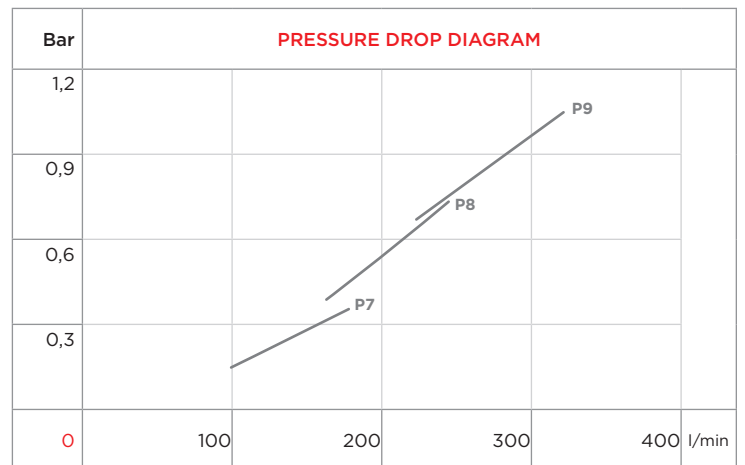
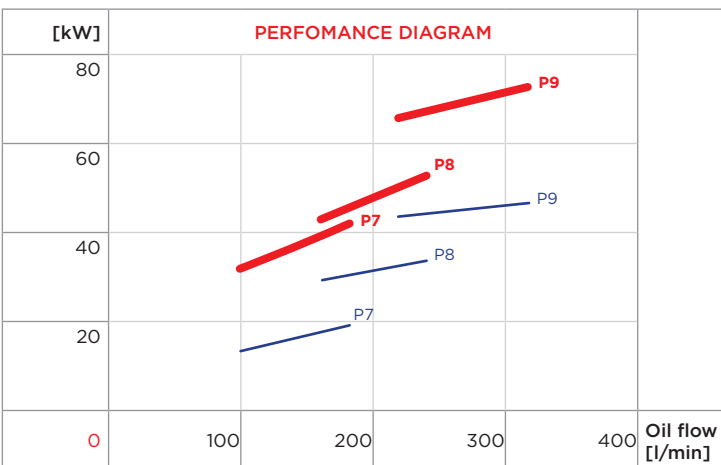

CORRECTION FACTOR								
ΔT_m	10	15	20	25	30	35	40	
f	2,5	1,67	1,25	1	0,83	0,71	0,63	

CORRECTION FACTOR								
cSt	22	30	46	68	100	150	220	
f	0,4	0,6	1	1,5	2,3	3,3	4,6	

MS 172/7 P

- Dimensions and technical characteristics are not binding

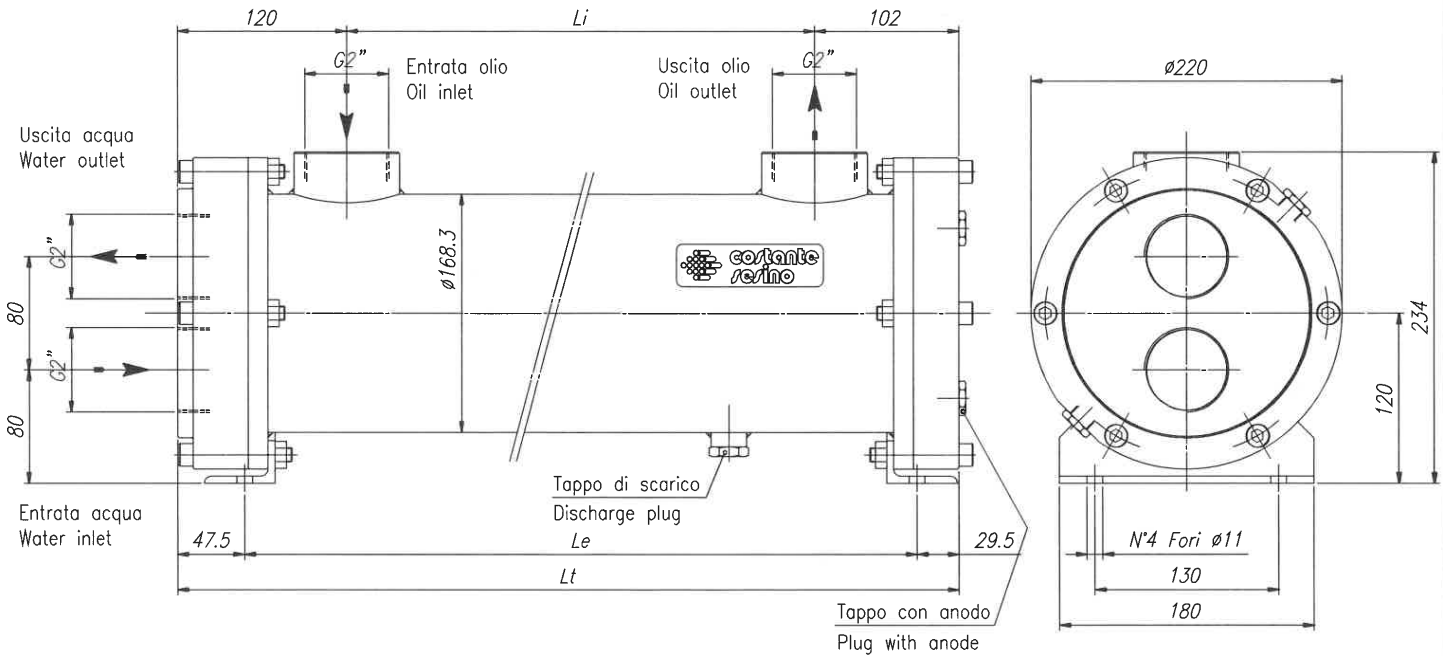

Static working pressure = 12 bar

Test pressure = 15 bar

TYPE	CODE	OIL FLOW l/min	WATER FLOW l/min	kW MIN water flow		kW MAX water flow		WEIGHT kg	DIMENSIONS		
				ΔTm 25° C	ΔTm 25° C	ΔTm 25° C	ΔTm 25° C		Li	Le	Lt
MS 172/7 P1	2SC172/7P1	100-240	67,5-270	28	34	42	54	42	355	500	600
MS 172/7 P2	2SC172/7P2	160-400	67,5-270	50	57	78	92	50,5	505	650	750
MS 172/7 P3	2SC172/7P3	260-420	67,5-270	63	71	110	136	59	655	800	900
MS 172/7 P4	2SC172/7P4	340-500	67,5-270	76	92	136	171	68,5	830	975	1075
MS 172/7 P5	2SC172/7P5	180-320	67,5-270	88	96	143	170	78	1005	1150	1250
MS 172/7 P6	2SC172/7P6	140-500	67,5-270	89	117	148	230	86	1155	1300	1400
MS 172/7 P7	2SC172/7P7	250-550	67,5-270	113	138	200	267	97	1355	1500	1600

CONSTRUCTION MATERIALS

SHELL	TUBES	END COVERS
CARBON STEEL*	COPPER*	CAST IRON*
STAINLESS STEEL AISI 304	STAINLESS STEEL AISI 304	STAINLESS STEEL AISI 304
CARBON STEEL	CuNi (water sea)	BRONZE

*standard

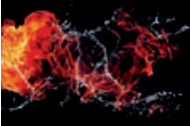

WATER-OIL HEAT EXCHANGERS WITH TUBE BUNDLE
SCAMBIATORI ACQUA-OLIO A FASCIO TUBIERO ESTRAIBILE



WATER FLOW RATE:



P1 P2

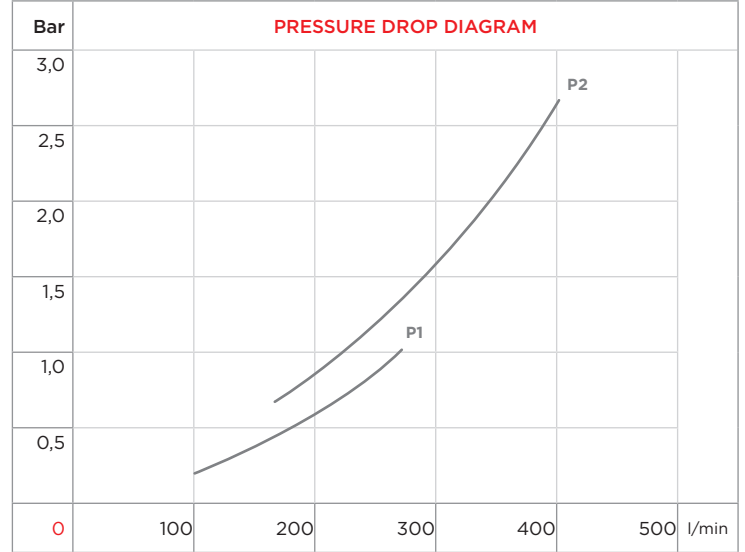
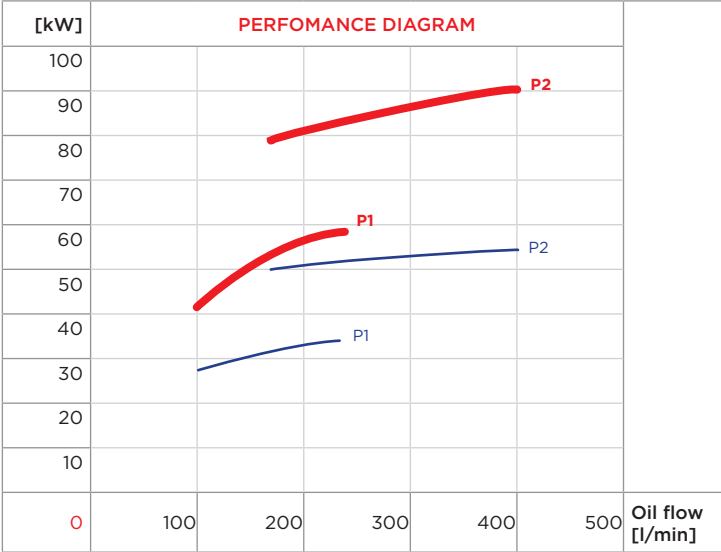

P3 P4

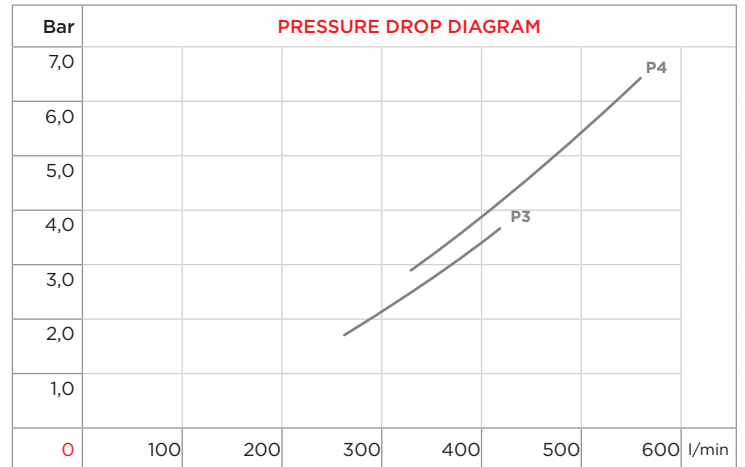
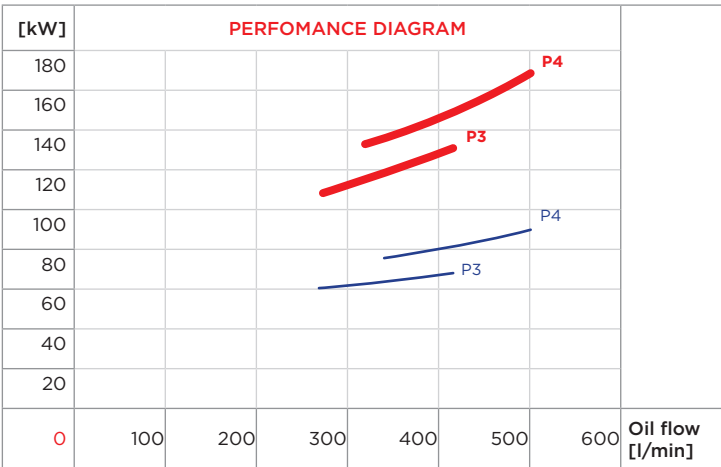

P5 P6 P7

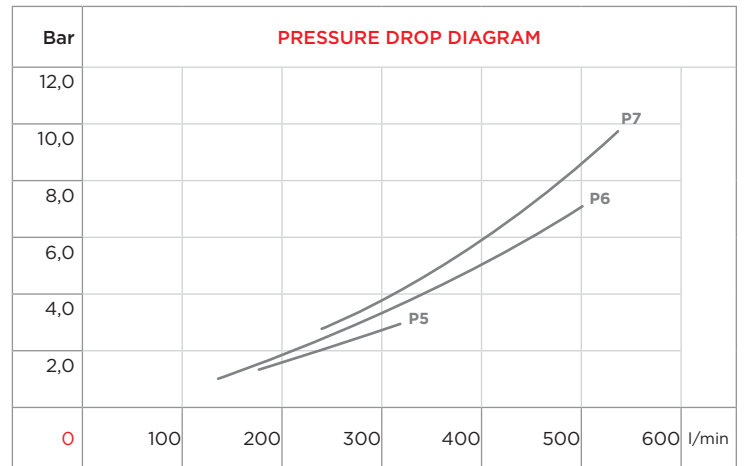
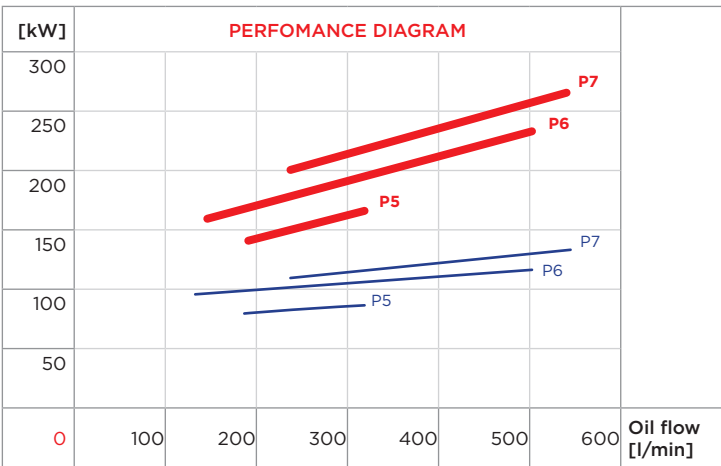

CORRECTION FACTOR								
ΔT_m	10	15	20	25	30	35	40	
f	2,5	1,67	1,25	1	0,83	0,71	0,63	

CORRECTION FACTOR								
cSt	22	30	46	68	100	150	220	
f	0,4	0,6	1	1,5	2,3	3,3	4,6	

MS 172/10 P

- Dimensions and technical characteristics are not binding

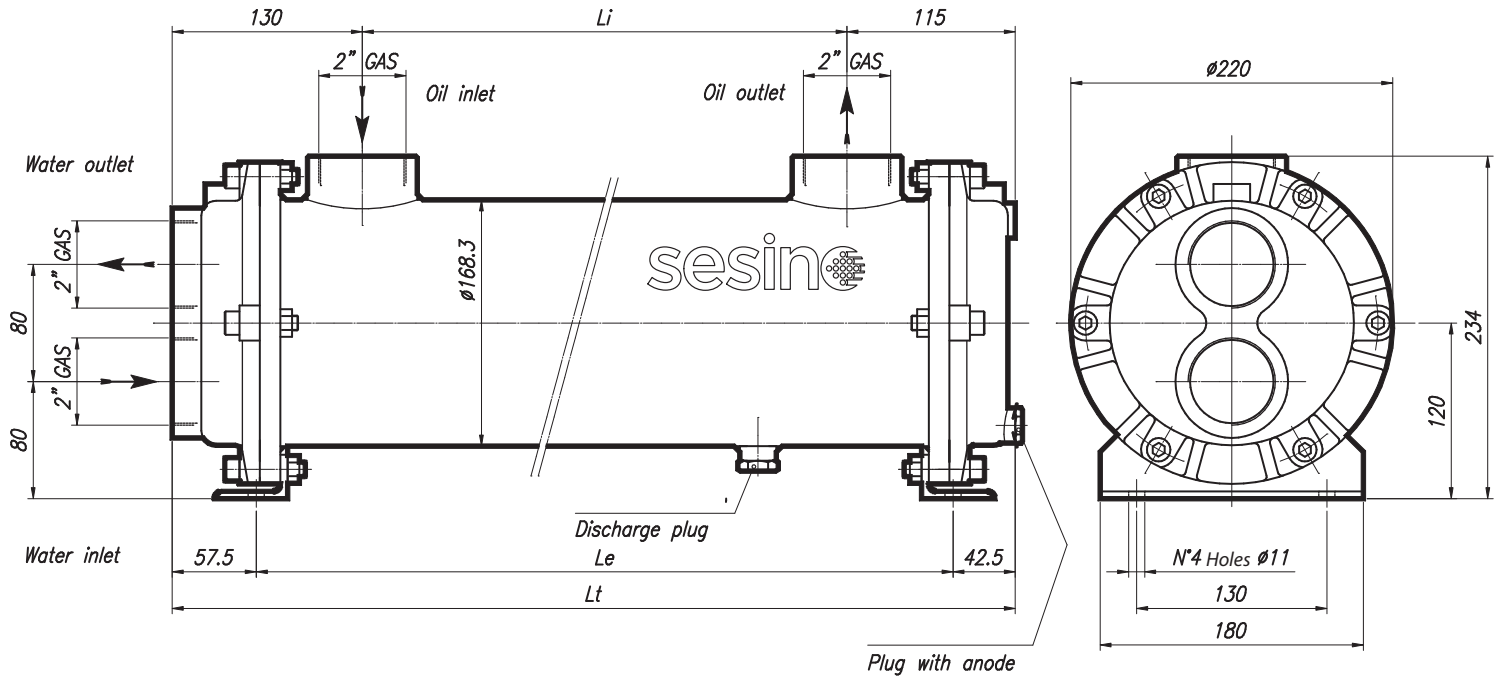

Static working pressure = 12 bar

Test pressure = 15 bar

TYPE	CODE	OIL FLOW l/min	WATER FLOW l/min	kW MIN water flow		kW MAX water flow		WEIGHT kg	DIMENSIONS		
				ΔT_m 25° C	ΔT_m 25° C	ΔT_m 25° C	ΔT_m 25° C		Li	Le	Lt
MS 172/10 P1	2SC172/10P1	100-400	67,5-270	13	18	16	24	36	355	500	600
MS 172/10 P2	2SC172/10P2	100-400	67,5-270	22	28	31	41	42,5	505	650	750
MS 172/10 P3	2SC172/10P3	120-450	67,5-270	31	38	44	55	54,5	655	800	900
MS 172/10 P4	2SC172/10P4	120-450	67,5-270	26	39	35	56	63	830	975	1075
MS 172/10 P5	2SC172/10P5	120-450	67,5-270	51	57	69	88	71,5	1005	1150	1250
MS 172/10 P6	2SC172/10P6	100-550	67,5-270	46	61	61	85	79	1155	1300	1400
MS 172/10 P7	2SC172/10P7	100-550	67,5-270	69	89	90	115	88,5	1355	1500	1600

CONSTRUCTION MATERIALS

SHELL	TUBES	END COVERS
CARBON STEEL*	COPPER*	CAST IRON*
STAINLESS STEEL AISI 304	STAINLESS STEEL AISI 304	STAINLESS STEEL AISI 304
BRASS	CuNi (water sea)	BRONZE

*standard

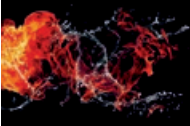

WATER-OIL HEAT EXCHANGERS WITH TUBE BUNDLE
SCAMBIATORI ACQUA-OLIO A FASCIO TUBIERO ESTRAIBILE



WATER FLOW RATE:

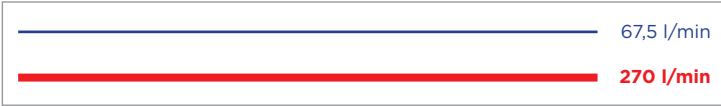

P1 P2 P3

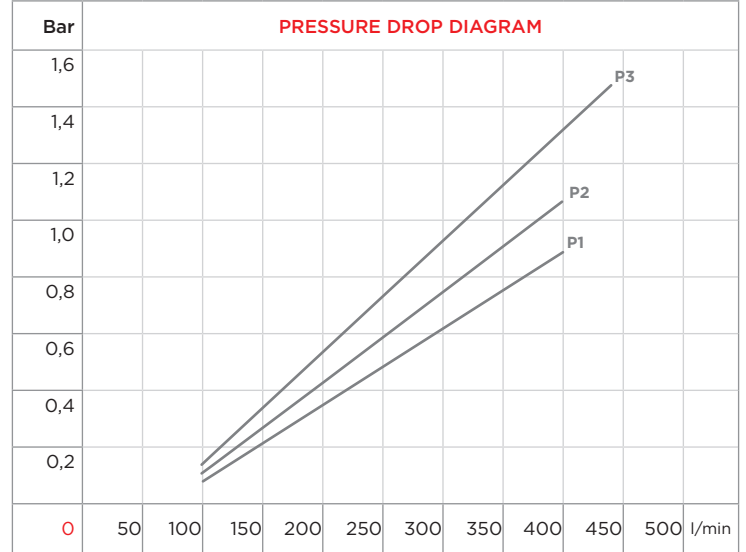
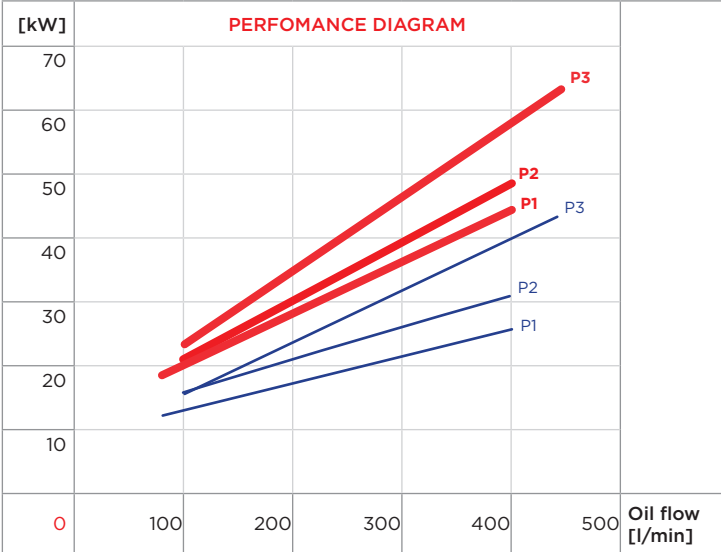

P4 P5

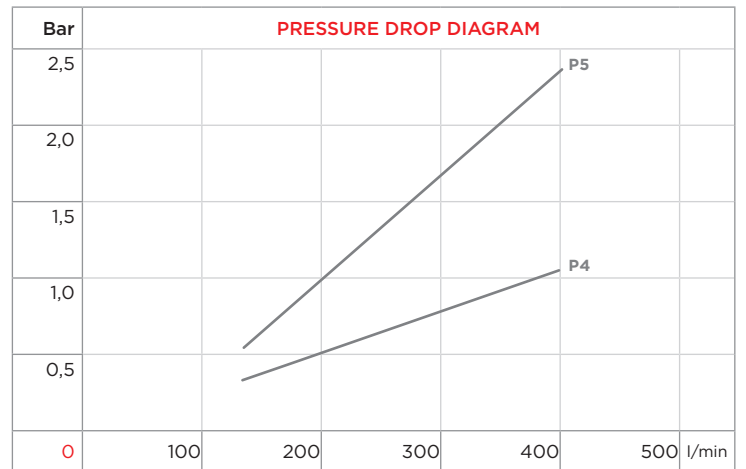
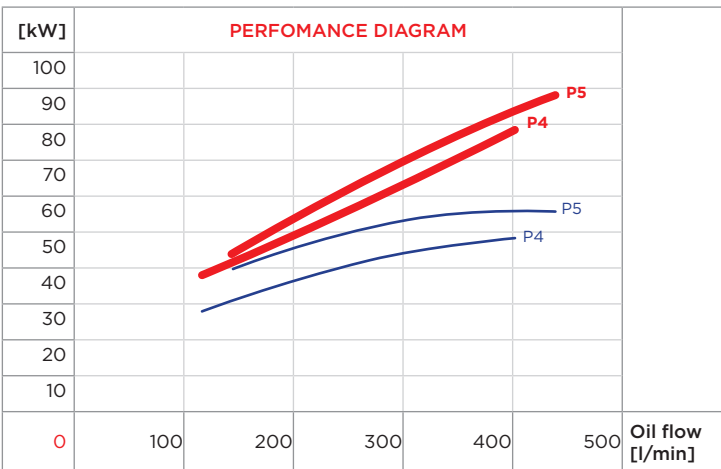

P6 P7

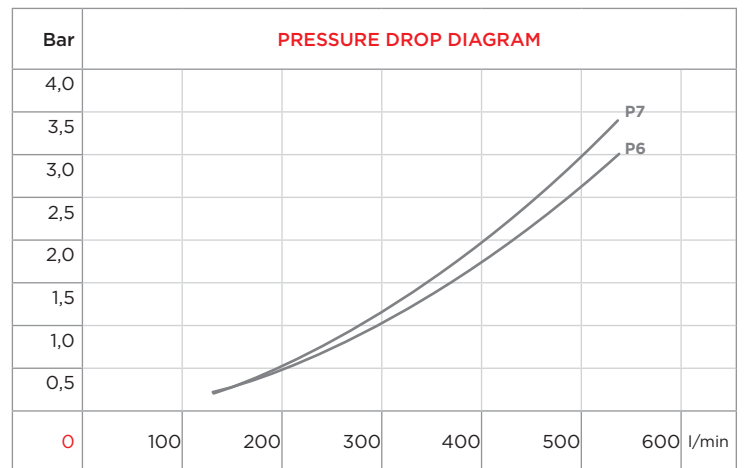
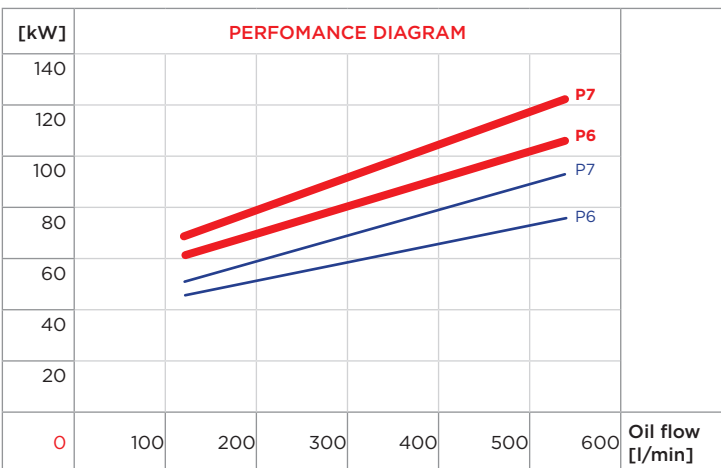

CORRECTION FACTOR								
ΔT_m	10	15	20	25	30	35	40	
f	2,5	1,67	1,25	1	0,83	0,71	0,63	

CORRECTION FACTOR								
cSt	22	30	46	68	100	150	220	
f	0,4	0,6	1	1,5	2,3	3,3	4,6	

MS 202 P

- Dimensions and technical characteristics are not binding

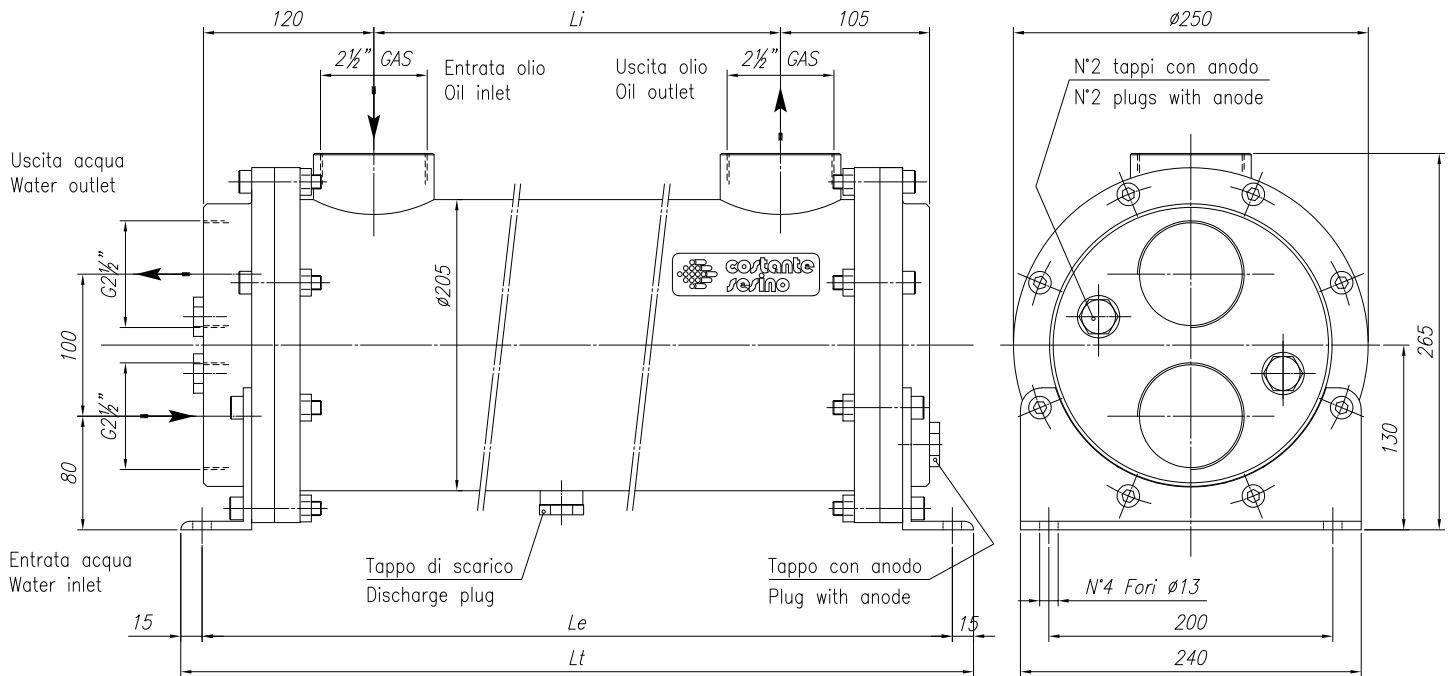

Static working pressure = 12 bar

Test pressure = 15 bar

TYPE	CODE	OIL FLOW	WATER FLOW	kW MIN water flow		kW MAX water flow		WEIGHT	DIMENSIONS		
		l/min	l/min	$\Delta T_m 25^\circ C$		$\Delta T_m 25^\circ C$			kg	Li	Le
MS 202 P1	2SC202P1	100-400	105-420	20	35	24	51	47	340	582	612
MS 202 P2	2SC202P2	160-460	105-420	29	50	39	69	56	500	742	772
MS 202 P3	2SC202P3	280-500	105-420	42	57	56	82	72,5	660	902	932
MS 202 P4	2SC202P4	260-560	105-420	46	76	67	109	84	820	1062	1092
MS 202 P5	2SC202P5	300-600	105-420	56	78	79	125	94	980	1222	1252
MS 202 P6	2SC202P6	340-600	105-420	73	98	98	148	104	1140	1382	1412
MS 202 P7	2SC202P7	280-460	105-420	68	90	92	123	114	1300	1542	1572
MS 202 P8	2SC202P8	400-600	105-420	102	134	141	177	124,5	1460	1702	1732
MS 202 P9	2SC202P9	460-660	105-420	132	168	176	221	135	1620	1862	1892
MS 202 P10	2SC202P10	520-800	105-420	145	197	191	260	145,5	1780	2022	2052

CONSTRUCTION MATERIALS

SHELL	TUBES	END COVERS
CARBON STEEL*	COPPER*	CAST IRON*
STAINLESS STEEL AISI 304	STAINLESS STEEL AISI 304	STAINLESS STEEL AISI 304
CARBON STEEL	CuNi (water sea)	BRONZE

*standard

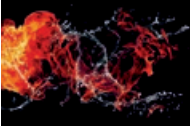

WATER-OIL HEAT EXCHANGERS WITH TUBE BUNDLE
SCAMBIATORI ACQUA-OLIO A FASCIO TUBIERO ESTRAIBILE



WATER FLOW RATE:

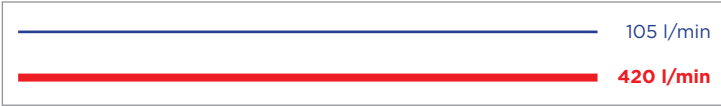

P1 P2 P3

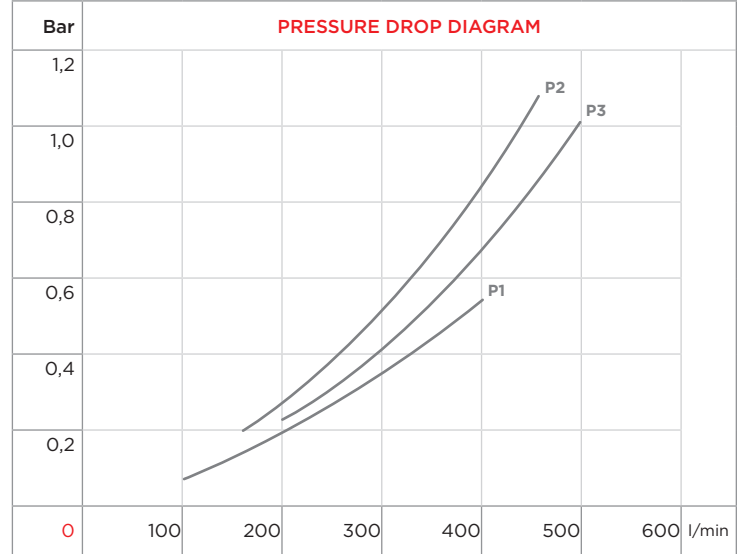

P4 P5 P6

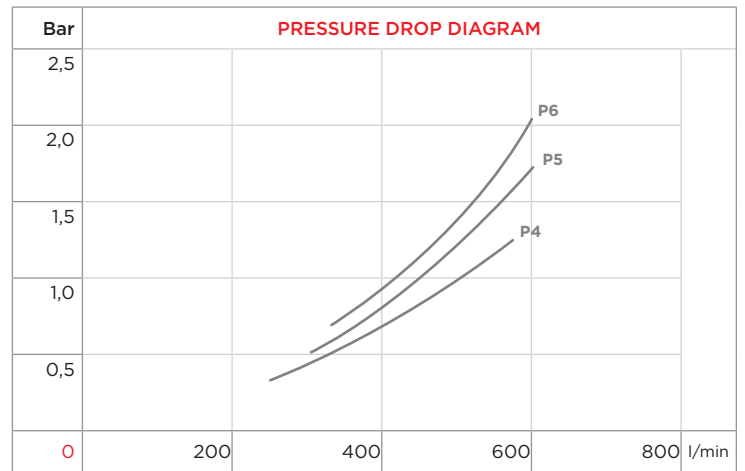
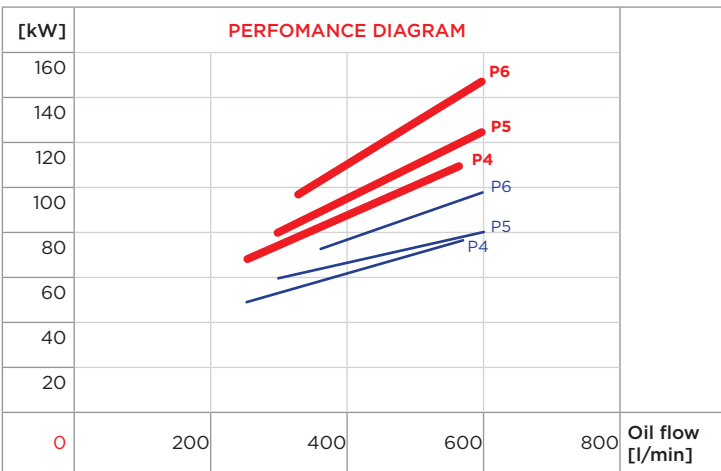

P7 P8 P9 P10

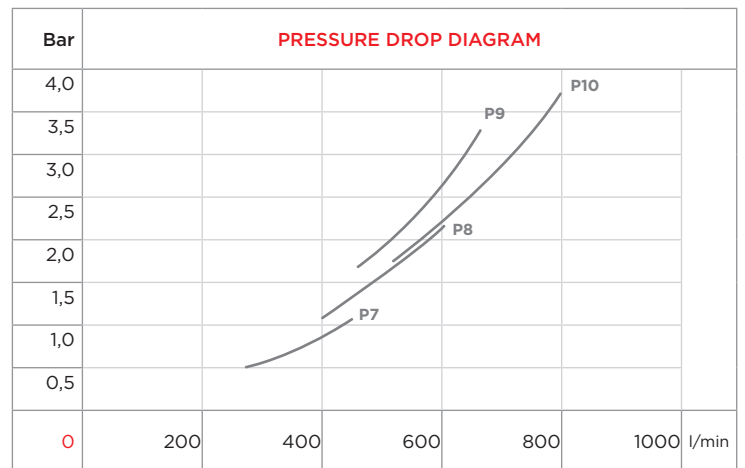
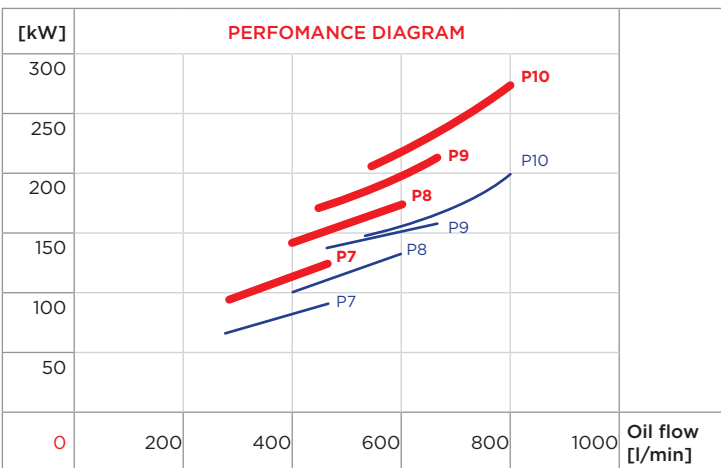

CORRECTION FACTOR

ΔT_m	10	15	20	25	30	35	40
f	2,5	1,67	1,25	1	0,83	0,71	0,63

CORRECTION FACTOR

cSt	22	30	46	68	100	150	220
f	0,4	0,6	1	1,5	2,3	3,3	4,6

MS 272 P

- Dimensions and technical characteristics are not binding

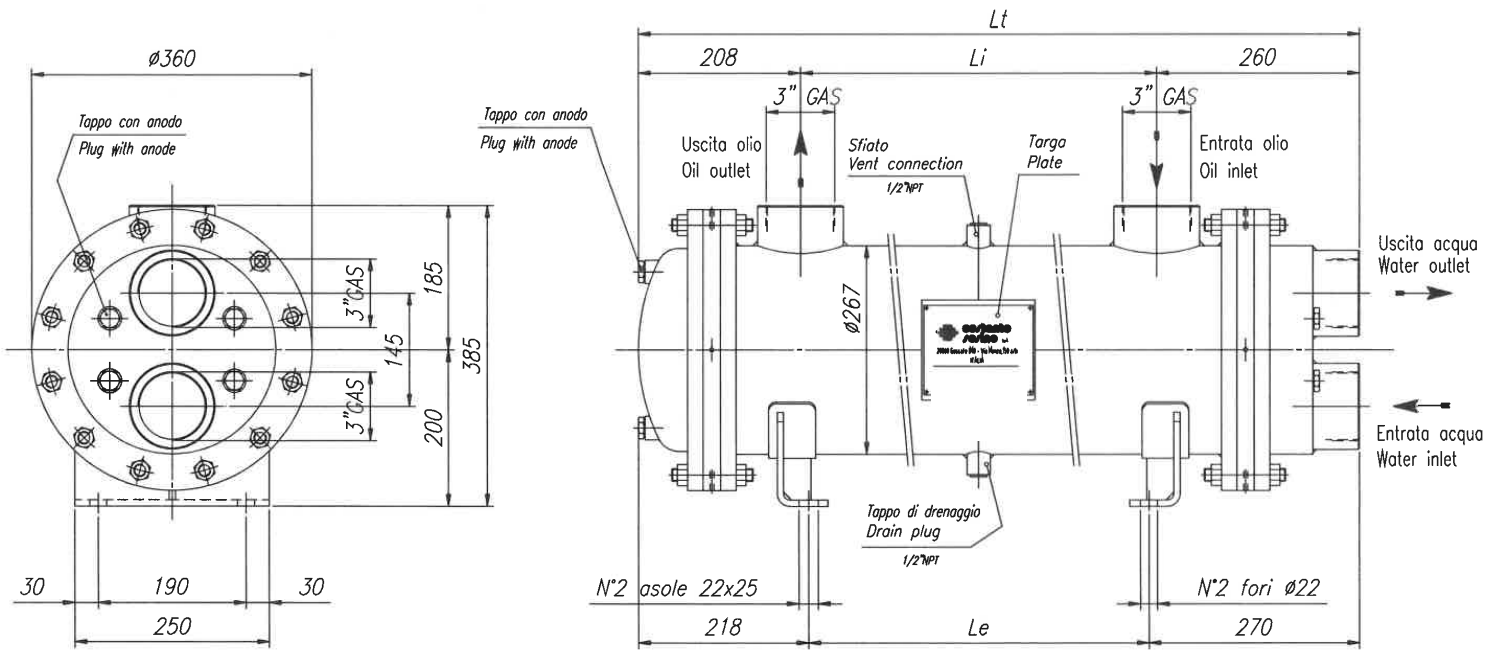

Static working pressure = 12 bar

Test pressure = 15 bar

TYPE	CODE	OIL FLOW l/min	WATER FLOW l/min	kW MIN water flow		kW MAX water flow		WEIGHT kg	DIMENSIONS		
				ΔT_m 25° C	ΔT_m 25° C	ΔT_m 25° C	ΔT_m 25° C		Li	Le	Lt
MS 272 P1	2SC272P1	190-350	146-583	28	36	37	51	142	255	235	723
MS 272 P2	2SC272P2	250-410	146-583	48	60	64	78	160	385	365	853
MS 272 P3	2SC272P3	310-450	146-583	56	66	81	97	172	505	485	973
MS 272 P4	2SC272P4	320-500	146-583	93	114	135	166	214	850	830	1318
MS 272 P5	2SC272P5	400-560	146-583	124	146	181	204	236	1040	1020	1508
MS 272 P6	2SC272P6	440-600	146-583	158	182	239	277	273	1360	1340	1828
MS 272 P7	2SC272P7	460-740	146-583	214	242	335	376	327	1825	1805	2293

CONSTRUCTION MATERIALS

SHELL	TUBES	END COVERS
CARBON STEEL*	COPPER*	CAST IRON*
STAINLESS STEEL AISI 304	STAINLESS STEEL AISI 304	STAINLESS STEEL AISI 304
CARBON STEEL	CuNi (water sea)	BRONZE

*standard

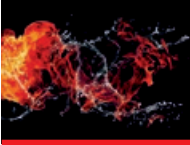

WATER-OIL HEAT EXCHANGERS WITH TUBE BUNDLE
SCAMBIATORI ACQUA-OLIO A FASCIO TUBIERO ESTRAIBILE



WATER FLOW RATE:



P1 P2 P3

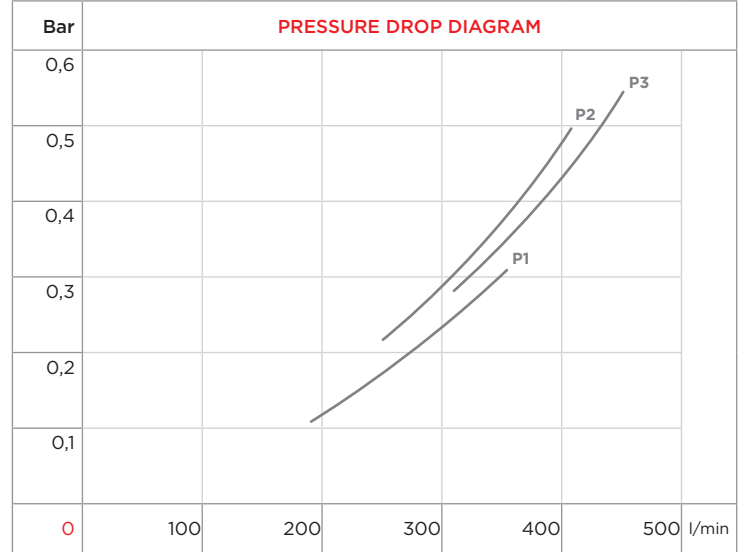

P4 P5 P6

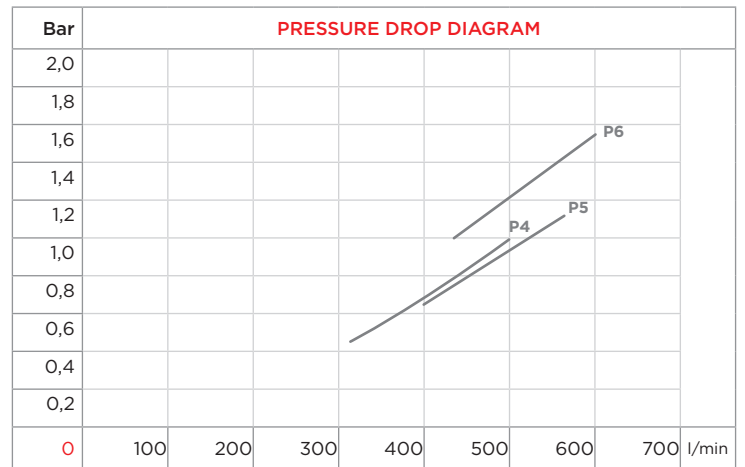
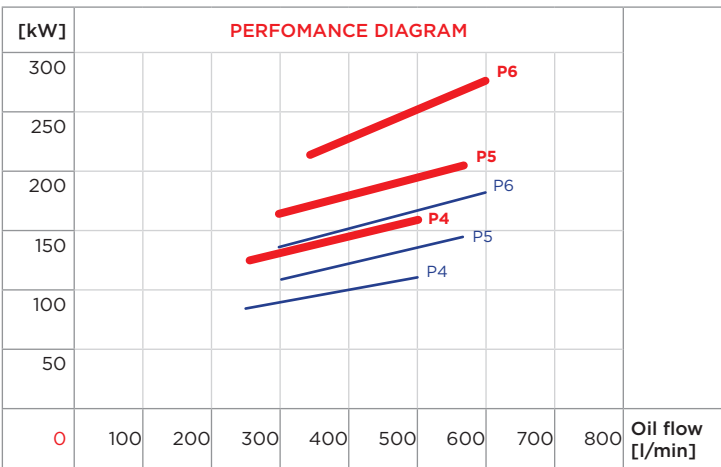

P7

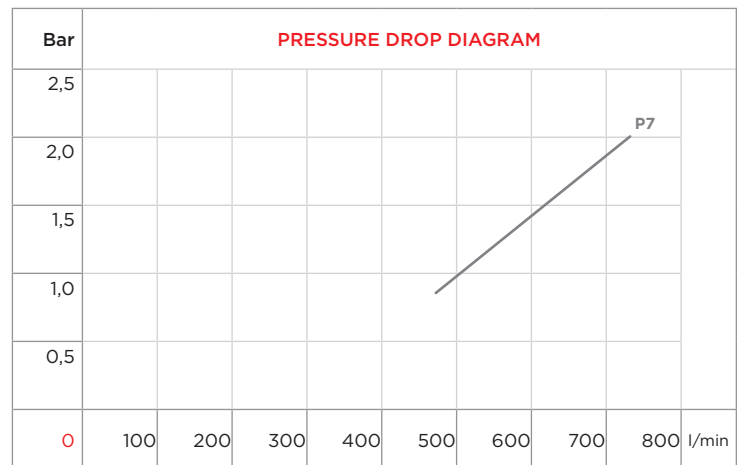
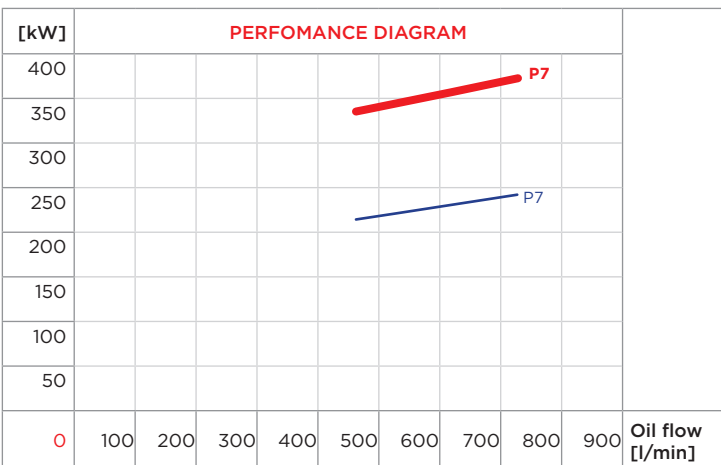

ΔT_m	10	15	20	25	30	35	40
f	2,5	1,67	1,25	1	0,83	0,71	0,63

cSt	22	30	46	68	100	150	220
f	0,4	0,6	1	1,5	2,3	3,3	4,6

MS 352 P

- Dimensions and technical characteristics are not binding

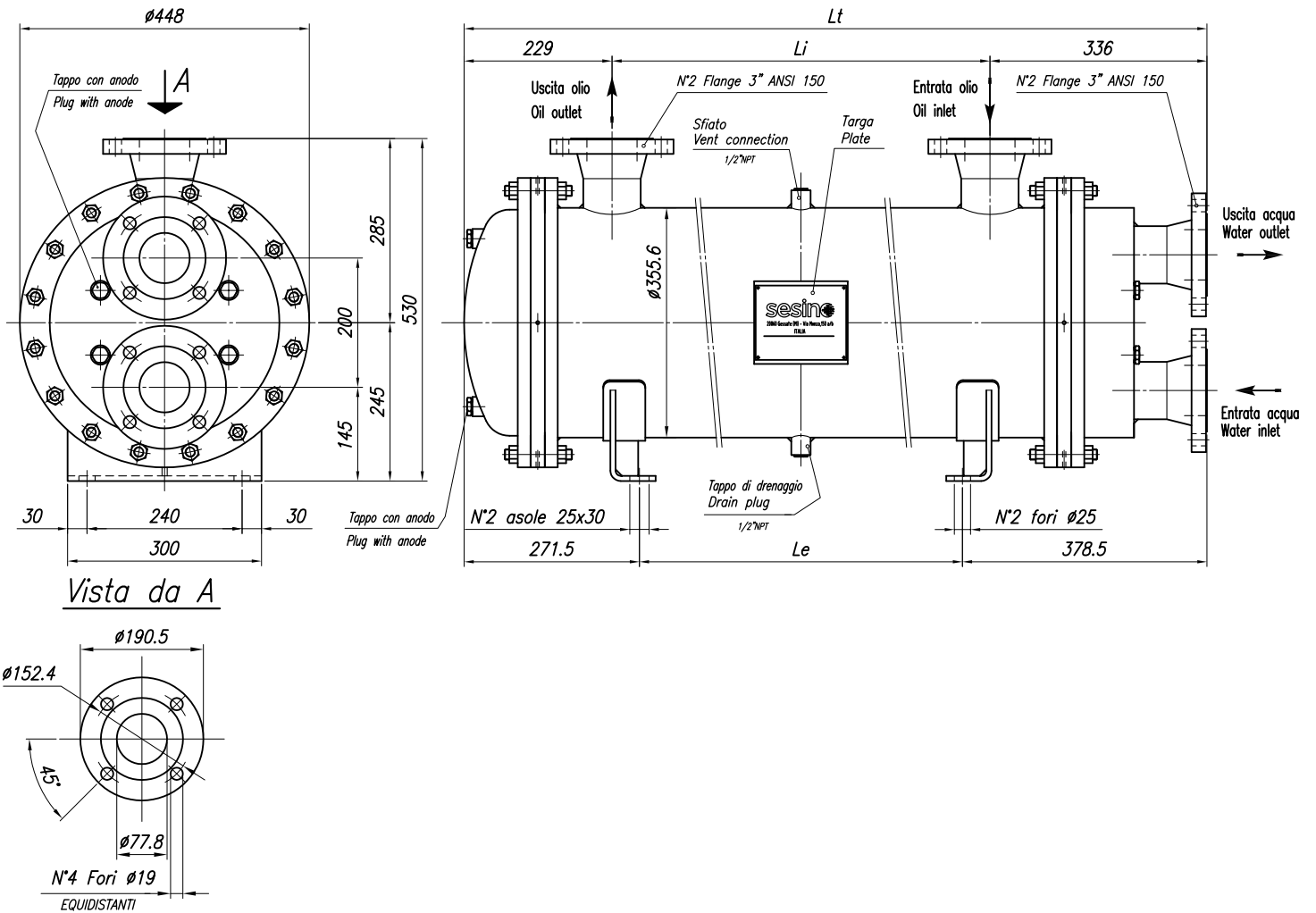

Static working pressure = 12 bar

Test pressure = 15 bar

TYPE	CODE	OIL FLOW	WATER FLOW	kW MIN water flow		kW MAX water flow		WEIGHT	DIMENSIONS		
		l/min	l/min	ΔT_m 25° C		ΔT_m 25° C			kg	Li	Le
MS 352 P1	2SC352P1	300-600	292-1166	117	180	148	258	400	985	900	1550
MS 352 P2	2SC352P2	400-700	292-1166	202	278	261	360	460	1280	1195	1845
MS 352 P3	2SC352P3	500-800	292-1166	247	310	333	415	525	1600	1515	2165
MS 352 P4	2SC352P4	300-680	292-1166	214	328	273	451	577	1845	1760	2410
MS 352 P5	2SC352P5	300-680	292-1166	232	370	295	513	640	2140	2055	2705

CONSTRUCTION MATERIALS

SHELL	TUBES	END COVERS
CARBON STEEL*	COPPER*	CAST IRON*
STAINLESS STEEL AISI 304	STAINLESS STEEL AISI 304	STAINLESS STEEL AISI 304
CARBON STEEL	CuNi (water sea)	BRONZE

*standard

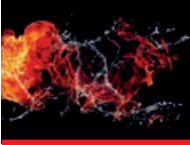

WATER-OIL HEAT EXCHANGERS WITH TUBE BUNDLE
SCAMBIATORI ACQUA-OLIO A FASCIO TUBIERO ESTRAIBILE



WATER FLOW RATE:



P1 P2

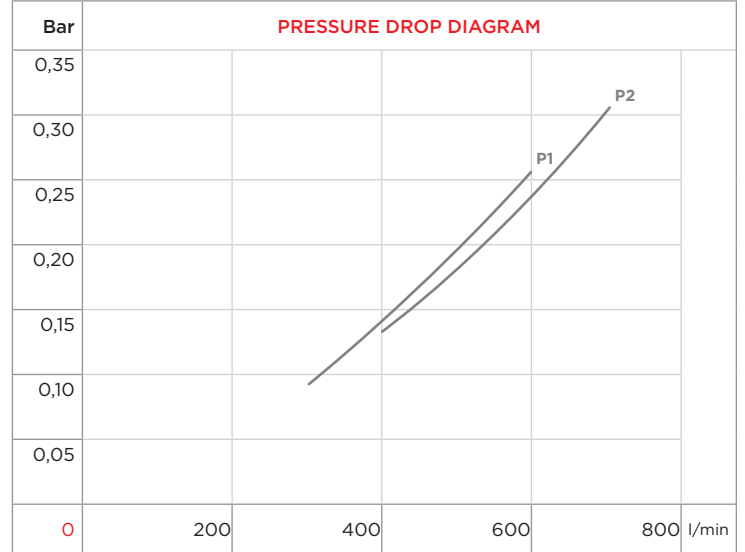
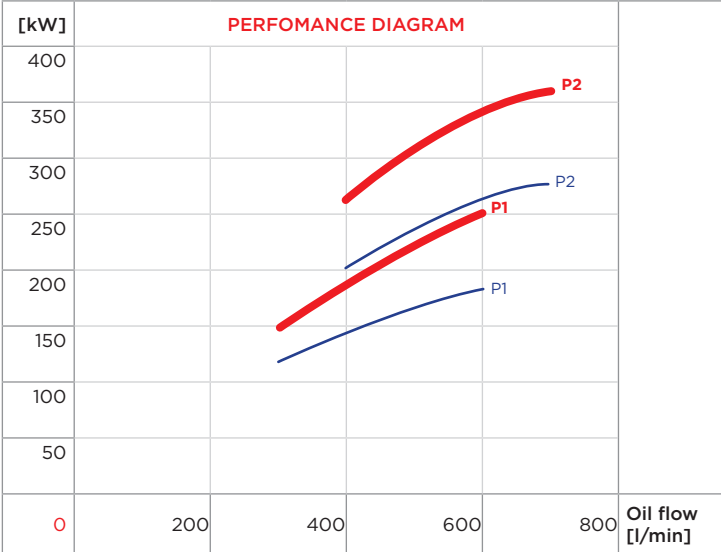

P3 P4

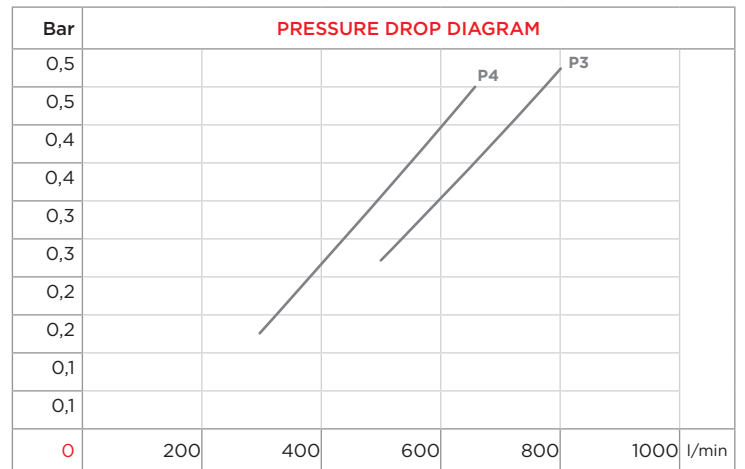
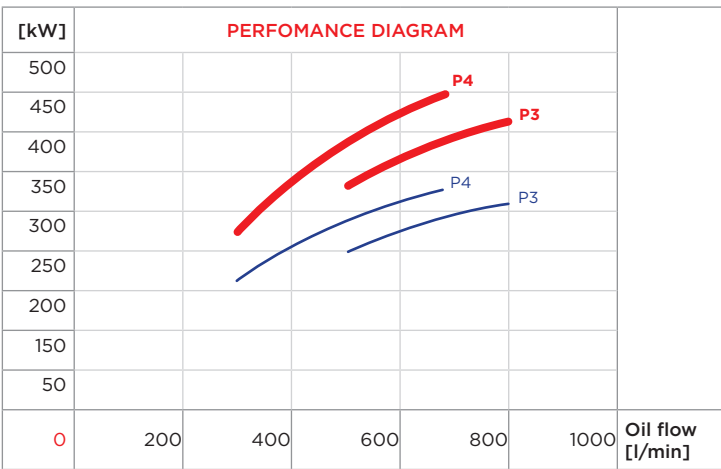

P5

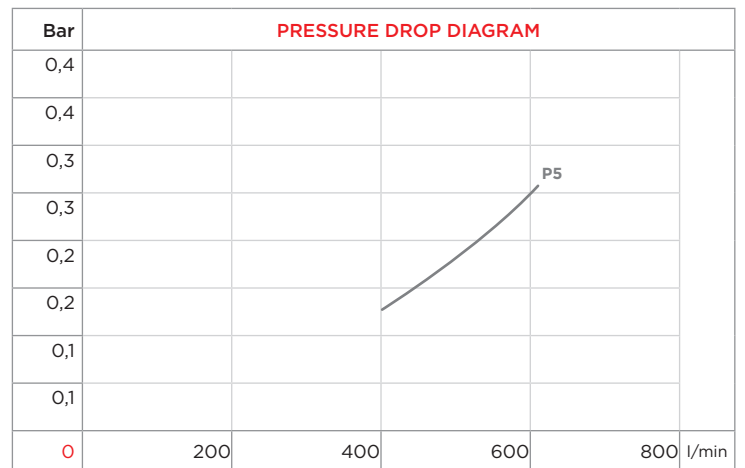
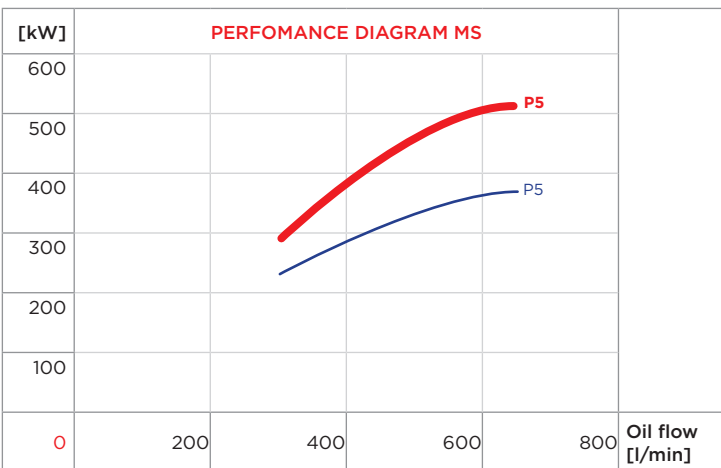

CORRECTION FACTOR								
ΔT_m	10	15	20	25	30	35	40	
f	2,5	1,67	1,25	1	0,83	0,71	0,63	

CORRECTION FACTOR								
cSt	22	30	46	68	100	150	220	
f	0,4	0,6	1	1,5	2,3	3,3	4,6	

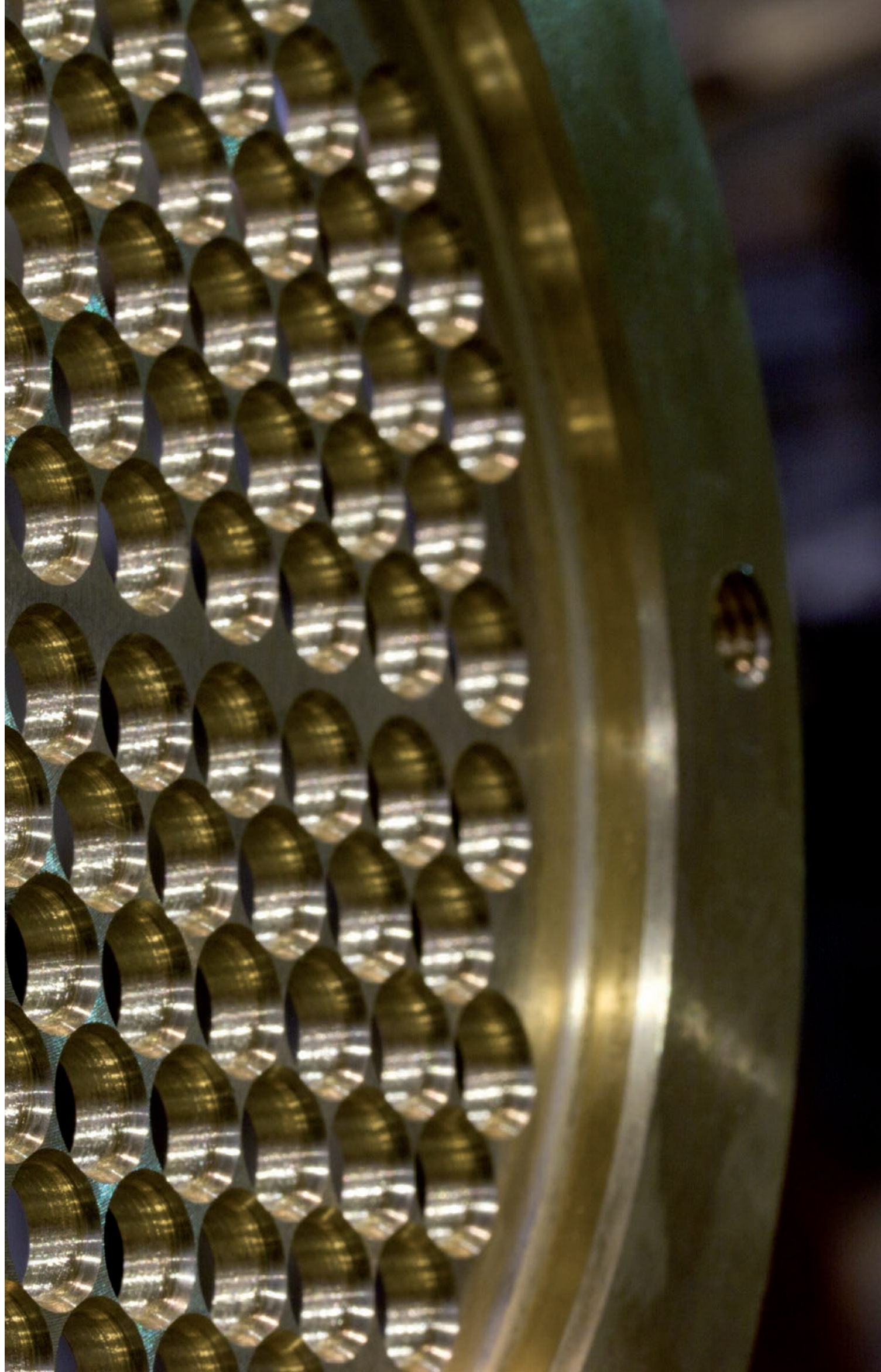

NOT INSPECTABLE WATER SIDE OUTSIDE/INSIDE THE TANK NON ISPEZIONABILI LATO ACQUA ESTERNI/INTERNI AL SERBATOIO

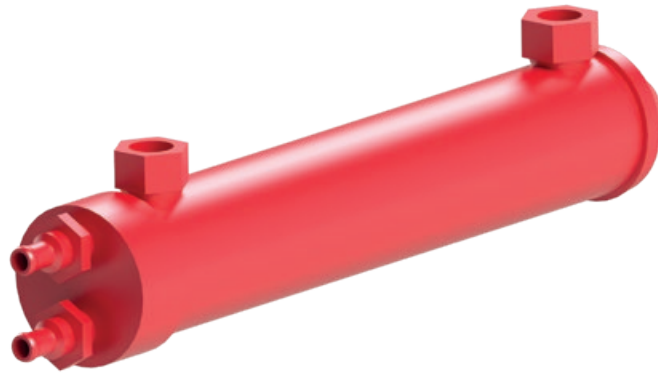

HEAT EXCHANGERS WITH NOT INSPECTABLE WATER SIDE TUBE BUNDLE, OUTSIDE/INSIDE THE TANK

They are exchangers with a maximum exchange surfaces of 0,7 mq, fit to cool little powerful plants.

The fixing of this kind of exchanger at the gearcase can be carried out through tubes for oil inlet and outlet, if rigid; or through clamps of our production, upon request.

They cannot be checked neither from the water side nor from the oil side and therefore cannot be used with dirty or not filtered fluids.

Thanks to their simple structure, their price is very competitive. They are chosen when the cheapness of the plant is very important.

SCAMBIATORI DI CALORE A FASCIO TUBIERO NON ISPEZIONABILI LATO ACQUA ESTERNI/ INTERNI AL SERBATOIO

Sono apparecchi con una superficie massima di 0,7 m², adatti quindi a raffreddare impianti di piccola potenza.

Il fissaggio di questi scambiatori alla centralina può essere effettuato per mezzo dei tubi di entrata e uscita olio, se rigidi, oppure per mezzo di fascette di nostra fornitura, su richiesta.

Non sono ispezionabili né lato acqua né lato olio e pertanto non possono essere impiegati con fluidi sporchi, o comunque non filtrati.

Data la loro semplicità costruttiva, il prezzo di questi scambiatori è estremamente competitivo e ciò li fa preferire nei casi in cui è preminente l'economicità dell'impianto.

T60-80 CB

- Dimensions and technical characteristics are not binding

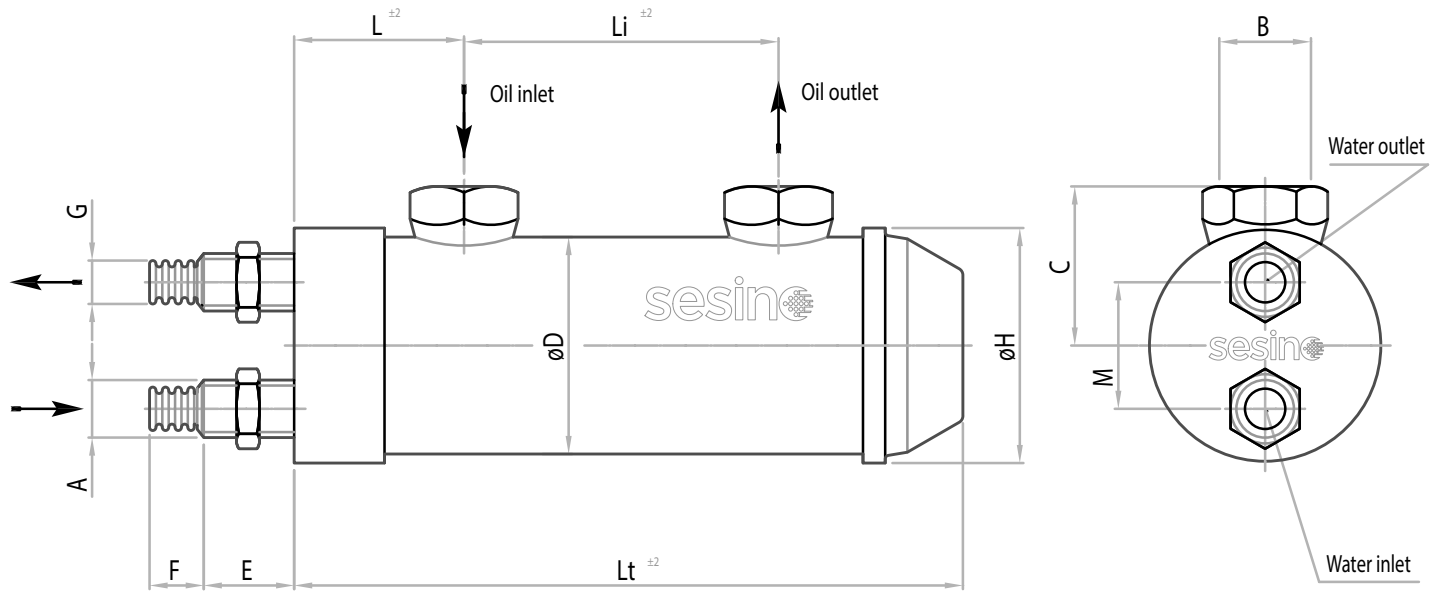

Static working pressure = 12 bar

Test pressure = 18 bar

TYPE	CODE	OIL FLOW l/min	WATER FLOW l/min	kW MIN water flow		kW MAX water flow		WEIGHT kg	DIMENSIONS											
				ΔT_m 25° C	ΔT_m 25° C	ΔT_m 25° C	ΔT_m 25° C		Lt	D	A	B	H	Li	G	M	C	L	F	E
T60 CB1	2SC60CB1	5-30	7,5 - 30	0,3	1,57	0,3	2,24	1,9	235	60	3/8" gas	1/2" gas	65	140	12	35	47	47	17	20
T60 CB2	2SC60CB2	5-30	7,5 - 30	0,4	2,44	0,61	3,48	2,6	355	60	3/8" gas	1/2" gas	65	260	12	35	47	47	17	20
T60 CB3	2SC60CB3	5-30	7,5 - 30	0,7	3,4	1	5,3	3,8	535	60	3/8" gas	1 1/2" gas	65	440	12	35	47	47	17	20
T80 CB1	2SC80CB1	20-50	7,5 - 30	2,33	2,94	2,9	3,89	3,2	255	80	1/2" gas	3/4" gas	85	120	17	45	65	60	20	20
T80 CB2	2SC80CB2	20-60	7,5 - 30	3,4	4,49	4,43	6,12	5,1	415	80	1/2" gas	3/4" gas	85	280	17	45	65	60	20	20
T80 CB3	2SC80CB3	30-80	7,5 - 30	5,95	7,3	8,13	10,5	8,0	665	80	1/2" gas	3/4" gas	85	530	17	45	65	60	20	20

CONSTRUCTION MATERIALS

SHELL	TUBES	END COVERS
BRASS	COPPER	BRASS

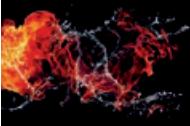

WATER-OIL HEAT EXCHANGERS WITH TUBE BUNDLE
SCAMBIATORI ACQUA-OLIO A FASCIO TUBIERO



WATER FLOW RATE:



T60: CB1 CB2 CB3

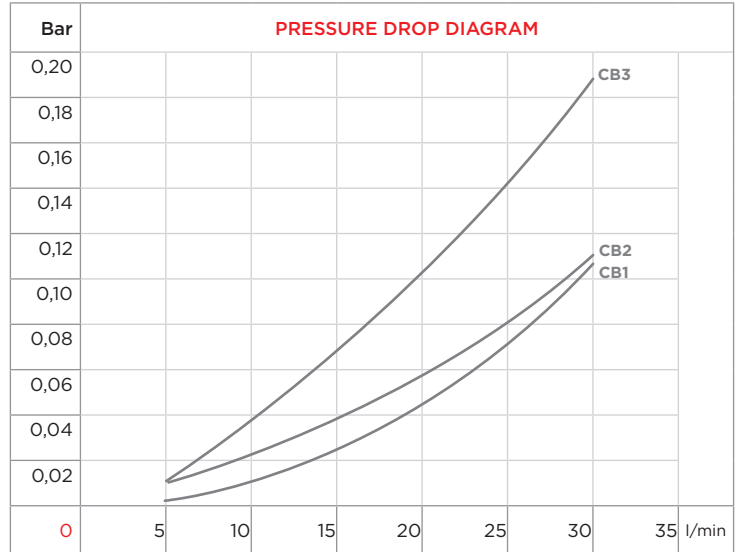
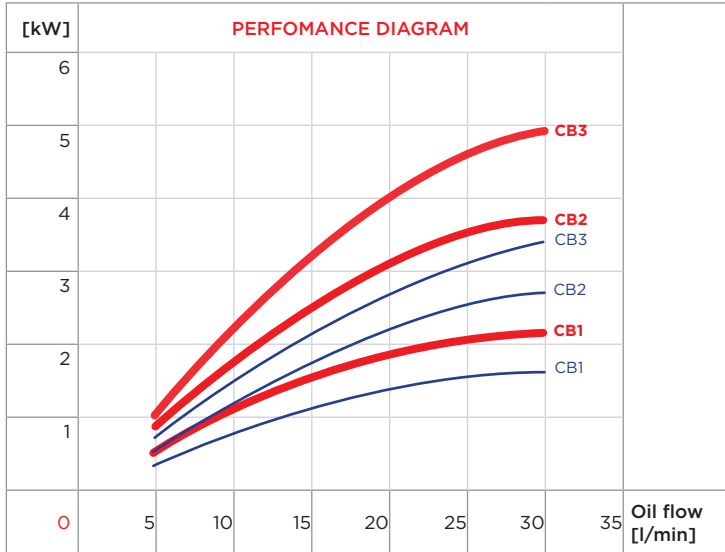

T80: CB1 CB2 CB3

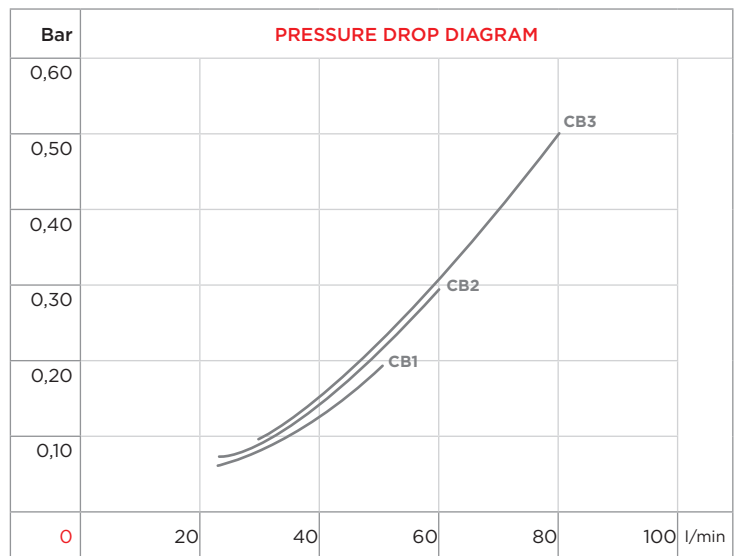
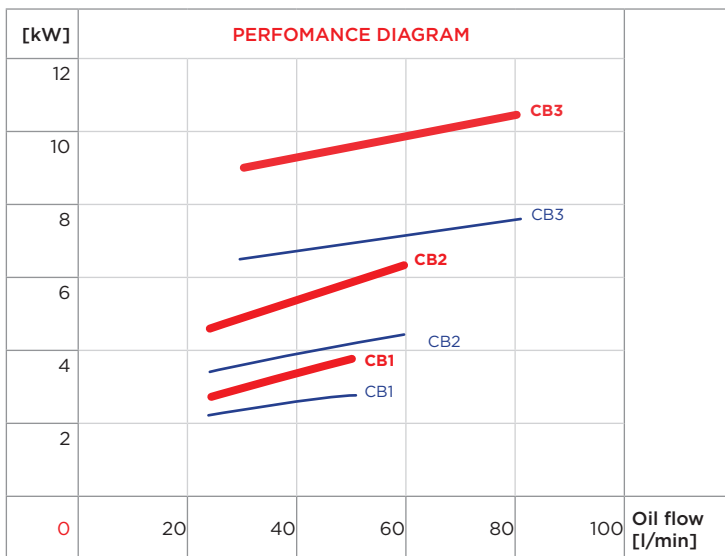

CORRECTION FACTOR

ΔT_m	10	15	20	25	30	35	40
f	2,5	1,67	1,25	1	0,83	0,71	0,63

CORRECTION FACTOR

cSt	22	30	46	68	100	150	220
f	0,4	0,6	1	1,5	2,3	3,3	4,6

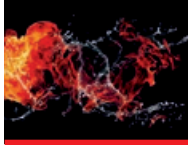

ASSEMBLING AND MAINTENANCE INSTRUCTIONS OF THE TUBE BUNDLE HEAT EXCHANGERS

Assembling

The water-oil heat exchangers are generally fixed in the return circuit. It is also possible to carry out a separate circuit through a self-contained pump. This is recommended when the outlet oil rates are variable. In this way, it is possible to obtain a better thermic performance.

In the hydraulic systems is probable to encounter some pressure peaks that could approach or exceed the maximum allowable pressure of the exchanger. In this case, it is recommended to supply it with a self-contained pump.

Note! These pulsations move inside the oil at the sound velocity and therefore they cannot be gauged with standard manometers, but only with a proper electronic instrumentation. The connection of the oil-water fittings must be carried out so that air can be easily blown out with the normal fluid circulation. This means that, if the exchanger is installed horizontal, water must flow in the lowest fitting and the oil fittings must be turned upwards; if otherwise it is vertical, the water fittings must be placed on the upper side and oil must flow in the lowest fitting.

MAINTENANCE OF NOT ISPECTABLE TUBE BUNDLE HEAT EXCHANGERS WATER SIDE

Oil side cleaning

The exchanger must be disassembled.

To remove the impurities it is necessary to let a detergent circulate for a time, which can vary from 10 to 30 minutes. Later proceed removing the detergent through the circulation of hot water.

During this operation, it is recommended to comply with the anti-pollution standards.

Water side cleaning

It is recommended to check the exchanger every 2 or 3 months to avoid that calcareous sediments completely close the little tubes inside which water flows. In this case the exchanger must be replaced.

If the exchanger is lightly obstructed, it is recommended to use a solution with water and 15% hydrochloric acid or similar fluids, and let it circulate into the water side of the exchanger, but in the opposite direction of the normal water flow. Remove afterwards any trace of the corrosive product letting some hot water flow for some minutes.

MAINTENANCE OF INSPECTABLE TUBE BUNDLE HEAT EXCHANGERS WATER SIDE

Oil side cleaning

The exchanger must be disassembled.

To remove the impurities it is necessary to let a detergent circulate for a time, which can vary from 10 to 30 minutes. Later proceed removing the detergent through the circulation of hot water.

During this operation, it is recommended to comply with the anti-pollution standards.

Water side cleaning

It is recommended to check the exchanger every 2 or 3 months to avoid that calcareous sediments completely close the little tubes inside which water flows. In this case, the exchanger must be replaced.

To carry out the check it is necessary to disconnect the exchanger from the water inlet and outlet tubes and remove the two heads, which stop the water circuit. If the exchanger is lightly obstructed, it is recommended to assemble both the heads and to use a solution with water and 15% hydrochloric acid or similar fluids, and let it circulate in the opposite direction of the normal water flow. Remove afterwards any trace of the corrosive product letting some hot water flow for some minutes.

Otherwise if the exchanger is obstructed not by calcareous sediments but by mud or by other solid sediments, it is enough to use a pig inside the tubes and then to rinse with a water jet. In any case, before reassembling the two heads, it is necessary to check that the zinc anode is clean and not damaged; otherwise, it must be replaced.

If the zinc anode is worn out in a short time, it is recommended to check the efficiency of the earthing of the machine on which the exchanger is assembled; wandering currents could cause some corrosions.

ISTRUZIONI MONTAGGIO E FUNZIONAMENTO SCAMBIATORI A FASCIO TUBIERO

Montaggio

Gli scambiatori acqua-olio sono generalmente installati nel circuito di ritorno. E' possibile anche realizzare un circuito separato con una pompa autonoma e ciò è consigliabile nel caso in cui le portate olio allo scarico siano molto variabili; ciò facendo si ottiene un miglioramento di resa termica. Nei sistemi idraulici possono verificarsi dei picchi di pressione che potrebbero avvicinarsi o superare la pressione massima ammissibile dello scambiatore; in questo caso è indispensabile alimentare lo stesso con una pompa autonoma.

Attenzione! Queste pulsazioni percorrono l'olio alla velocità del suono e non sono pertanto misurabili con normali manometri, ma solo con un'adatta strumentazione elettronica. Il collegamento dei raccordi acqua e olio deve essere eseguito in modo che l'aria possa essere agevolmente espulsa con la normale circolazione dei fluidi. Ciò significa che, se lo scambiatore è installato in posizione orizzontale, l'acqua deve entrare nel raccordo posto più in basso ed i raccordi olio devono essere rivolti verso l'alto, mentre, se installati in posizione verticale, i raccordi acqua devono essere nella parte superiore e l'olio deve entrare nel raccordo posto più in basso.

MANUTENZIONE SCAMBIATORI A FASCIO TUBIERO NON ISPEZIONABILI LATO ACQUA

Pulizia lato olio

Per tale tipo di pulizia lo scambiatore deve essere smontato. Lo sporco può essere asportato con la circolazione di un prodotto detergente; la durata di questa operazione può variare dai 10 ai 30 minuti. Dopo questo procedimento il prodotto resta all'interno e bisognerà quindi procedere alla sua espulsione mediante circolazione di acqua calda. Durante questa operazione si raccomanda di rispettare le norme antinquinamento.

Pulizia lato acqua

E' sempre buona norma controllare lo scambiatore ogni 2 o 3 mesi di lavoro per evitare che il calcare otturi completamente i tubetti all'interno dei quali scorre l'acqua, nel qual caso lo scambiatore sarebbe da sostituire.

In caso di modesto intasamento è consigliabile far circolare nel lato acqua dello scambiatore, in senso opposto alla normale circolazione della stessa, una soluzione al 15% di acido cloridrico in acqua, oppure altri fluidi simili reperibili in commercio.

Terminata tale operazione è necessario espellere dallo scambiatore la benché minima traccia di prodotto corrosivo; per fare ciò è sufficiente far circolare acqua calda per qualche minuto.

MANUTENZIONE SCAMBIATORI A FASCIO TUBIERO ISPEZIONABILI LATO ACQUA

Pulizia lato olio

Per tale tipo di pulizia lo scambiatore deve essere smontato. Lo sporco può essere asportato con la circolazione di un prodotto detergente; la durata di questa operazione può variare dai 10 ai 30 minuti. Dopo questo procedimento e il prodotto resta all'interno e bisognerà quindi procedere alla sua espulsione mediante circolazione di acqua calda. Durante questa operazione si raccomanda di rispettare le norme antinquinamento.

Pulizia lato acqua

E' sempre buona norma controllare lo scambiatore ogni 2 o 3 mesi di lavoro per evitare che il calcare otturi completamente i tubetti all'interno dei quali scorre l'acqua, nel qual caso lo scambiatore sarebbe da sostituire.

Per l'ispezione è necessario scollegare lo scambiatore dai tubi di entrata ed uscita acqua e togliere le due testate che chiudono il circuito acqua.

Nel caso di modesto intasamento dovuto al calcare è consigliabile rimontare le due testate e far circolare, in senso opposto al normale flusso, una soluzione al 15% di acido cloridrico in acqua, oppure altri fluidi simili reperibili in commercio. Terminata tale operazione, è necessario espellere dallo scambiatore la benché minima traccia di prodotto corrosivo; per fare ciò è sufficiente far circolare acqua calda per qualche minuto.

Nel caso invece dall'ispezione risultasse che lo scambiatore fosse intasato non da sedimenti calcarei, ma da fango o da altre particelle solide contenute nell'acqua, è sufficiente agire con uno scovolo all'interno dei tubi e sciacquare successivamente con un getto d'acqua.

In ogni caso, prima di rimontare le testate, bisogna controllare che l'anodo di zinco sia integro e pulito; in caso contrario, non potendo svolgere la sua funzione sacrificale, deve essere sostituito.

Nel caso il suddetto anodo si fosse consumato in breve tempo, è indispensabile controllare l'efficienza della messa a terra della macchina sulla quale è installato lo scambiatore, perché la presenza di correnti vaganti potrebbe provocare rapidi fenomeni corrosivi.

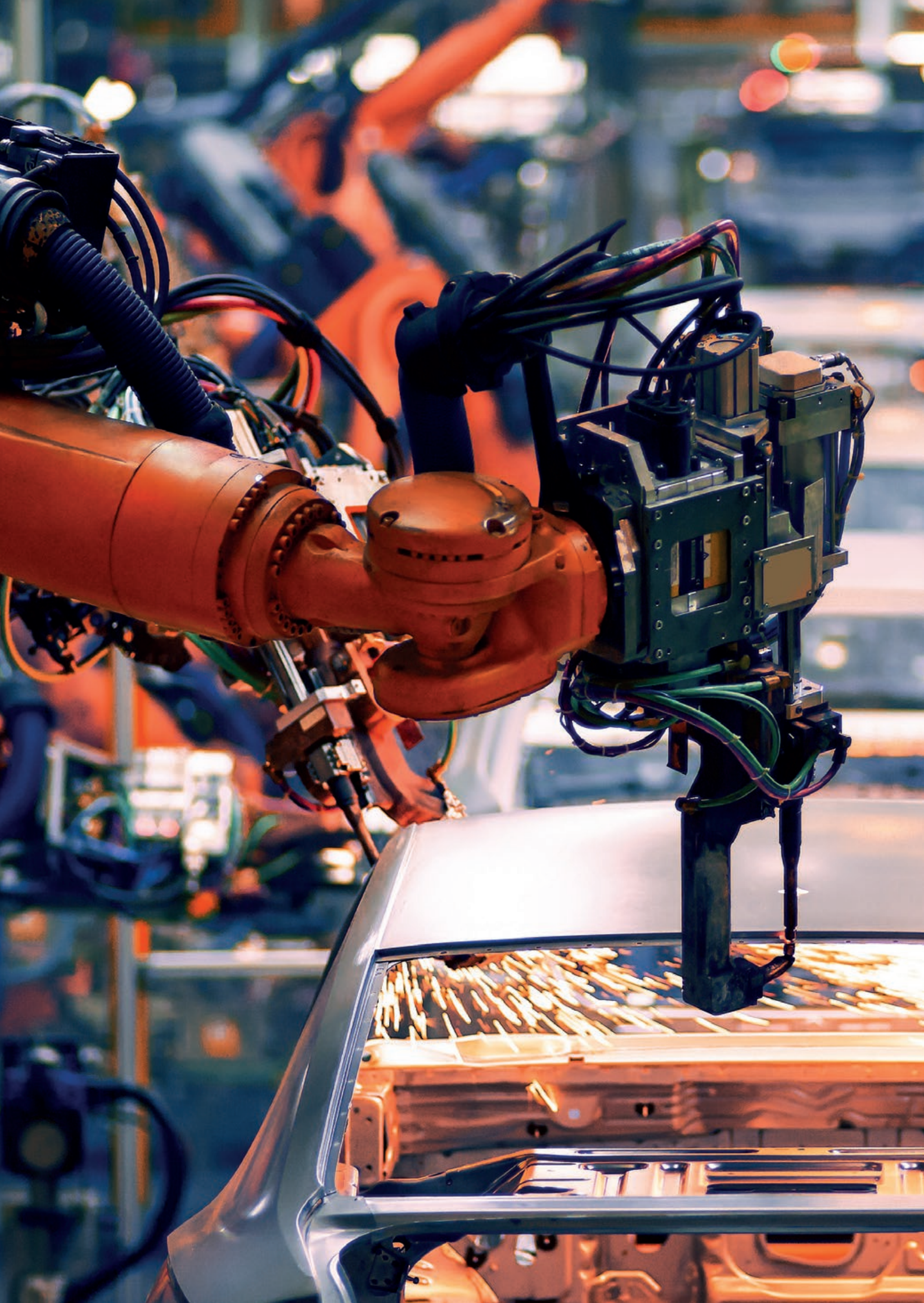



DESIGN AND OPERATING PRINCIPLES

The brazed plate heat exchanger is composed of pressed stainless steel plates that are brazed together using a copper alloy in a vacuum process. During the brazing process, the plates are stacked with each one rotated 180° relative to the previous, creating two separate flow chambers through which the fluids pass in opposite directions to exchange heat.

The embossing on the plates generates intense turbulence in the fluids, which significantly increases the heat transfer coefficients—even at low flow rates.

ADVANTAGES

- Compact and lightweight unit
- High heat transfer coefficient thanks to the special plate design
- Suitable for high temperature and pressure applications
- High corrosion resistance due to the stainless steel construction
- Easy to install and service; virtually maintenance-free
- Cost-effective thanks to the possibility of automated production

FOULING RESISTANCE

Brazed plate heat exchangers are significantly less prone to fouling — especially on the water side— compared to shell-and-tube exchangers. This is due to several factors:

- Turbulent flow is maintained even at low water flow rates
- There are no low-velocity areas, as water is evenly distributed throughout the exchanger
- Limescale particles cannot adhere to the plate surfaces due to their high-quality surface finish

PRINCIPI COSTRUTTIVI E DI FUNZIONAMENTO

Lo scambiatore di calore a piastre saldobrasate è costituito da piastre di acciaio inossidabile stampate che vengono brasate con lega di rame in un processo sottovuoto.

Nel processo di brasatura le piastre vengono impacchettate ruotandole di 180° l'una con l'altra in modo da produrre due camere di flusso separate nelle quali i fluidi che si devono scambiare il calore scorrono in direzioni opposte.

Le stampature presenti sulle piastre generano un'intensa turbolenza nei fluidi che incrementa i coefficienti di scambio termico anche in presenza di scarsi flussi volumetrici.

VANTAGGI

- Unità compatta e leggera
- Coefficiente di scambio termico elevato grazie al particolare disegno delle piastre
- Temperatura e pressione di esercizio elevate
- Essendo le piastre di acciaio inossidabile, alta resistenza alla corrosione
- Semplicità di installazione e di riparazione; non richiede praticamente manutenzione
- Economicità grazie alla possibilità di automatizzarne la produzione

RESISTENZA ALLE INCROSTAZIONI

Gli scambiatori a piastre saldobrasati sono molto meno sensibili alle incrostazioni, che si verificano soprattutto nel lato acqua, degli scambiatori a fascio tubiero. Questo grazie ai seguenti fattori:

- Si è sempre in presenza di flusso turbolento anche con portate d'acqua basse
- Non esistono aree di bassa velocità perché l'acqua viene distribuita uniformemente all'interno dello scambiatore
- Le particelle di calcare non possono aderire alla superficie delle piastre essendo la loro finitura superficiale molto accurata

WATER-OIL HEAT EXCHANGERS WITH BRAZED PLATES SCAMBIATORI DI CALORE ACQUA-OLIO A PIASTRE SALDO BRASATE

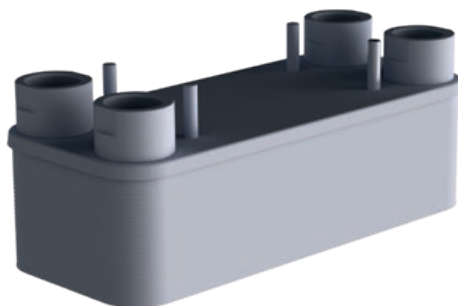

For each exchanger, the thermic performance curves, as a function of the oil rate, show the heatload in KW that the exchanger is able to dissipate with 50°C inlet oil temperature and 25°C inlet water temperature.

The water flow rate considered into the plot is 1/2 of oil flow rate

Per ogni scambiatore i grafici di performance termica, in funzione della portata olio, mostrano la potenza dissipata con temperatura olio in ingresso 50°C e temperatura acqua in ingresso 25°C.

La portata acqua considerata nei grafici è 1/2 della portata olio

Pressure drop plots are valid for ISO VG 46 oil.
For different performance and pressure drop condition or for additional specification, please contact Sesino SpA for a specific analysis.

*Le perdite di carico sono valide con olio ISO VG 46.
Per differenti condizioni di performance e perdite di carico o per specifiche aggiuntive, consigliamo di contattare il nostro Ufficio Tecnico*

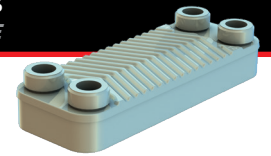

- Dimensions and technical characteristics are not binding

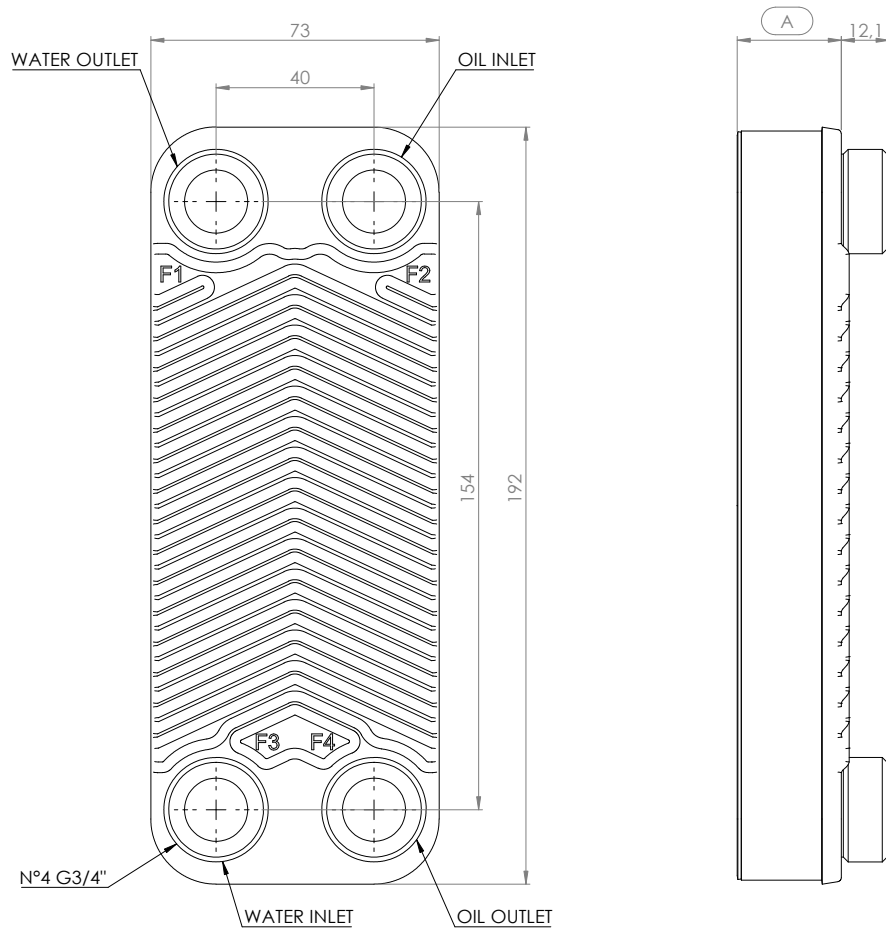

Static working pressure = 16 bar

TYPE	SURFACE	OIL FLOW	WEIGHT (no connections)	DIMENSIONS
	m ²	l/min	kg	A
M5-10S	0,09	5÷30	1	26,4
M5-30S	0,33	25÷80	1,8	69,8

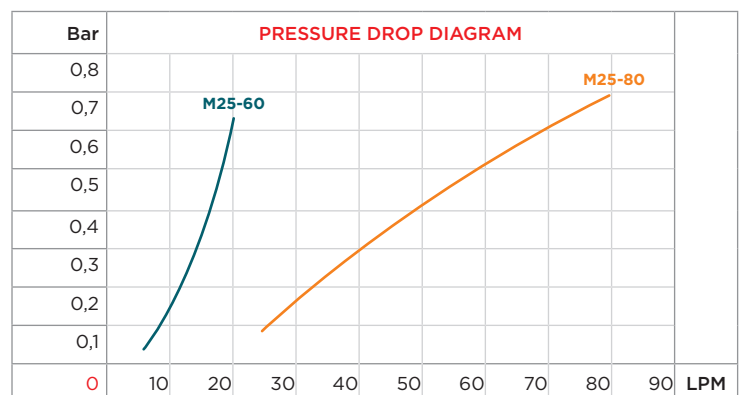
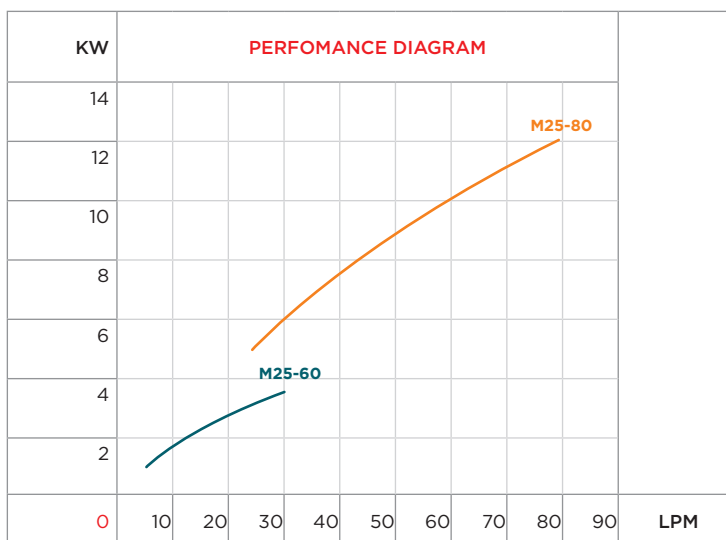

CORRECTION FACTOR

cSt	22	30	46	68	100	150	220
f	0,4	0,6	1	1,5	2,3	3,3	4,6

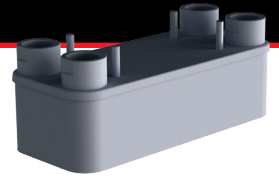

- Dimensions and technical characteristics are not binding

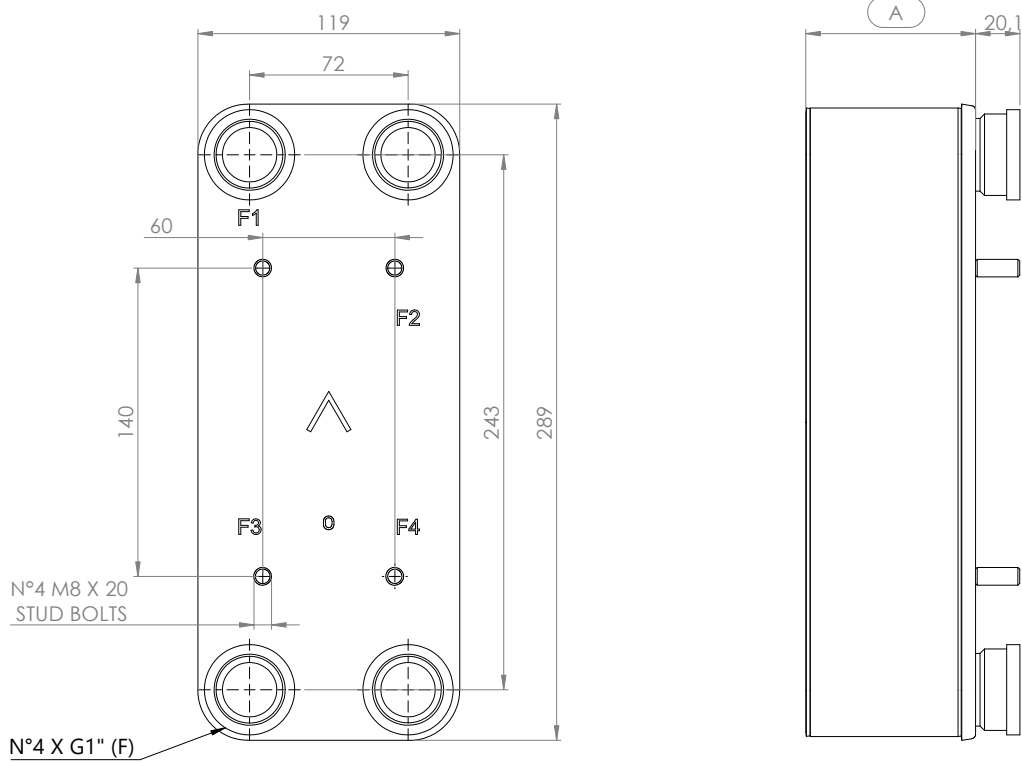

Static working pressure = 30 bar @100°C

TYPE	SURFACE m ²	OIL FLOW l/min	WEIGHT (no connections) kg	DIMENSIONS A
M18-10S	0,25	20÷80	2,5	32,4
M18-20S	0,56	40÷120	3	54,8
M18-30S	0,87	50÷160	4	77,2
M18-40S	1,18	60÷200	5	99,6
M18-50S	1,49	80÷240	6	122

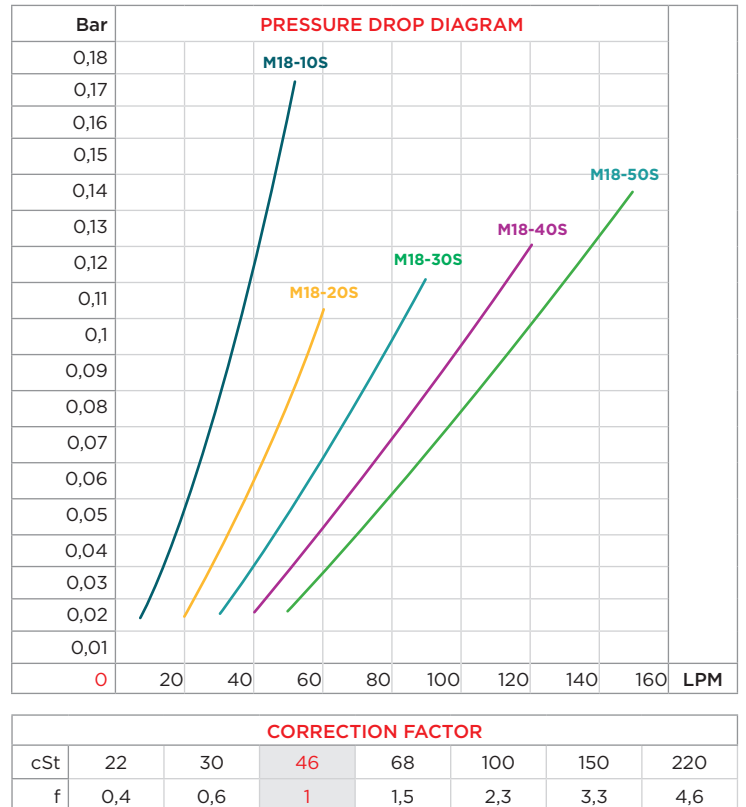
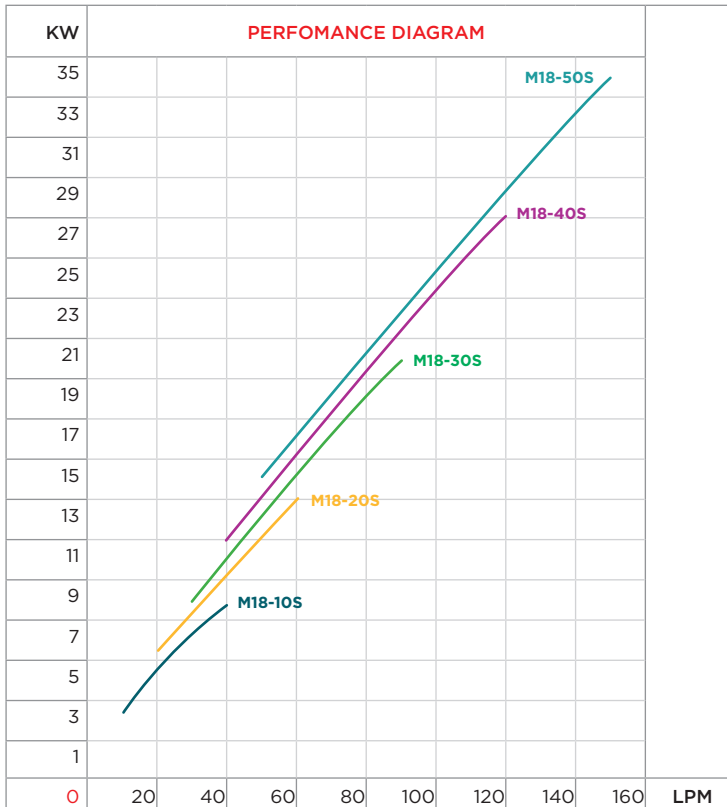

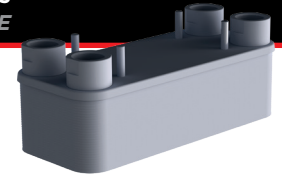

- Dimensions and technical characteristics are not binding

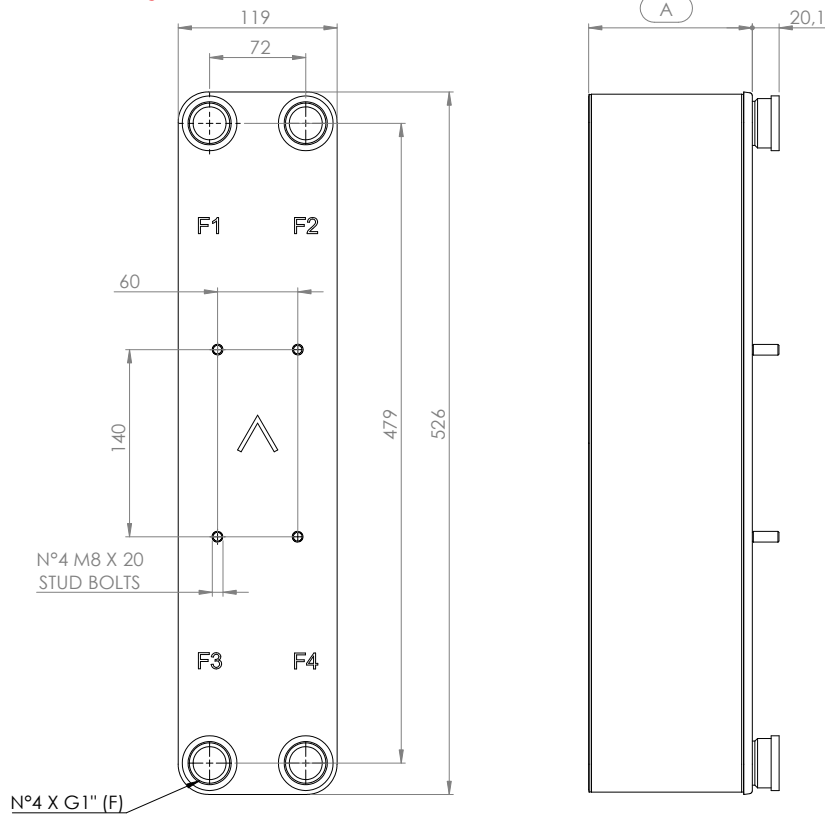

Static working pressure = 38 bar @100°C

TYPE	SURFACE	OIL FLOW	WEIGHT (no connections)	DIMENSIONS
	m ²	l/min	kg	A
M25-30S	1,76	20÷80	7	77,5
M25-40S	2,39	40÷120	9	100
M25-50S	3,02	50÷160	10	122,5
M25-60S	3,65	60÷200	12	145
M25-80S	4,91	80÷240	16	190

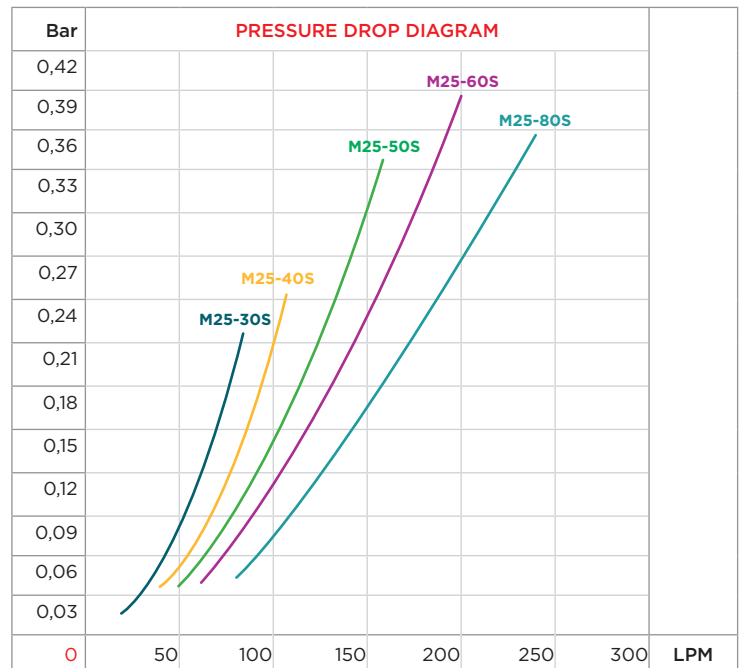
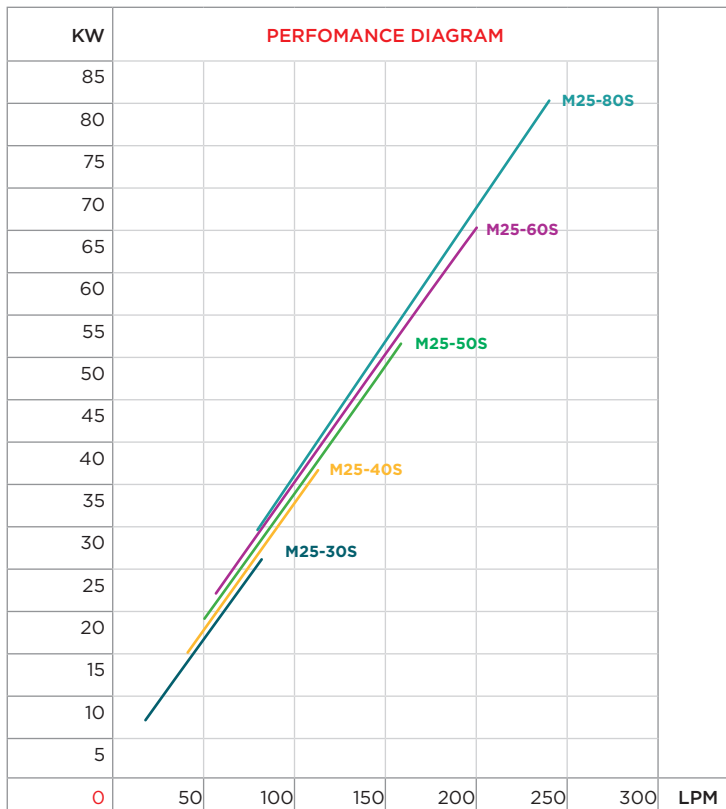

CORRECTION FACTOR							
cSt	22	30	46	68	100	150	220
f	0,4	0,6	1	1,5	2,3	3,3	4,6

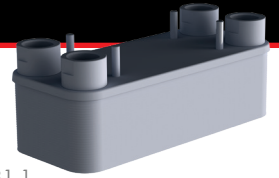

- Dimensions and technical characteristics are not binding

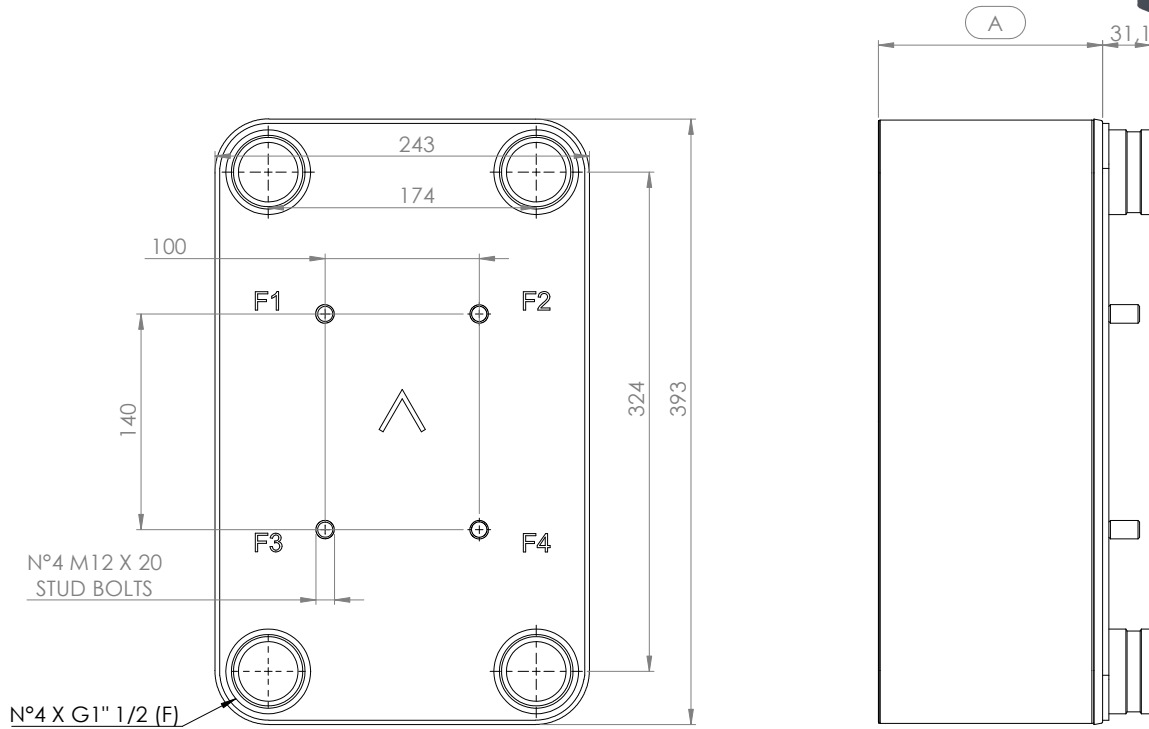

Static working pressure = 28 bar @100°C

TYPE	SURFACE	OIL FLOW	WEIGHT (no connections)	DIMENSIONS
	m ²			l/min
M55-30S	2,63	80÷240	15	81,8
M55-40S	3,57	100÷300	18	104,4
M55-50S	4,51	120÷340	20	127
M55-60S	5,45	140÷400	23	149,6
M55-80S	7,33	160÷420	28	194,8
M55-100S	9,21	200÷440	33	240

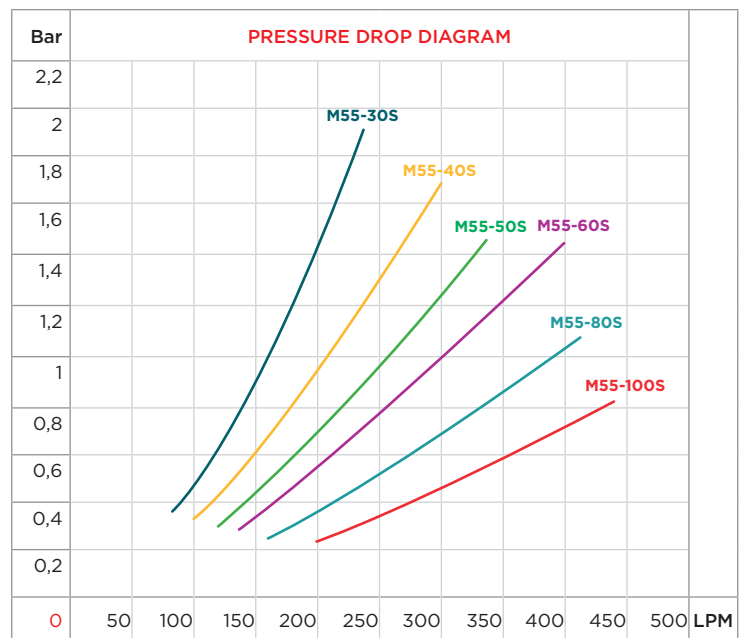
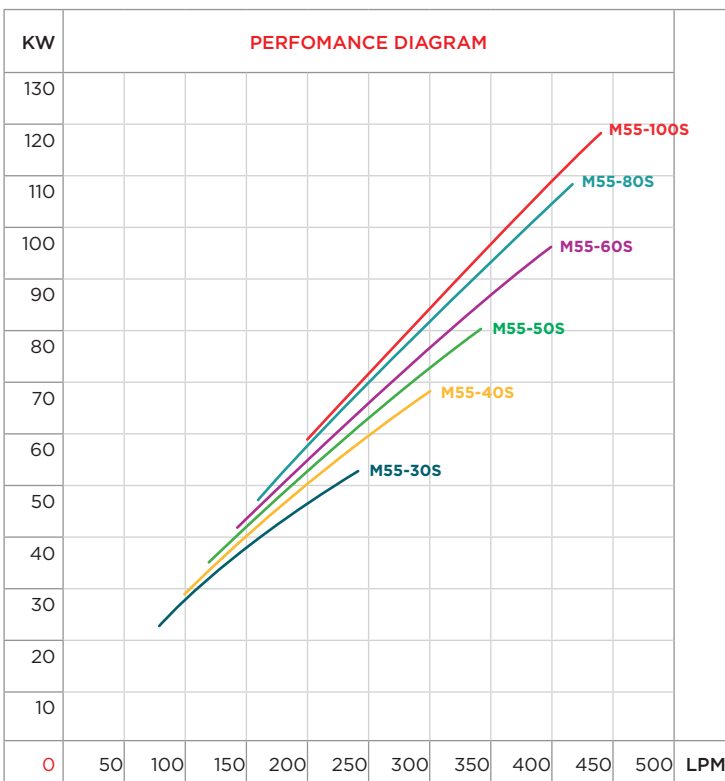

CORRECTION FACTOR

cSt	22	30	46	68	100	150	220
f	0,4	0,6	1	1,5	2,3	3,3	4,6

GASKETED PLATE HEAT EXCHANGERS SCAMBIATORI DI CALORE A PIASTRE ISPEZIONABILI

- Dimensions and technical characteristics are not binding



Designed to optimize thermal exchange performance and to simplify maintenance operations. These units offer the significant advantage of modularity, allowing the heat transfer surface to be increased or reduced over the component's operational life within the system.

Operating with parallel flow, they feature corrugated plates made of AISI 304L, 316L, SMO, Titanium, or Hastelloy, with a thickness of 0.5 mm. Plates are equipped with non-glued elastomer gaskets (NBR, EPDM, Viton, HNBR), galvanized steel tie rods, and frames rated PN10 or PN16, constructed from epoxy-painted steel. Available with various connection types, either threaded or flanged, depending on the model.

Progettati per ottimizzare le prestazioni di scambio termico e per ridurre e semplificare le operazioni di manutenzione. Hanno il grande vantaggio della modularità che consiste nel poter aumentare o diminuire la superficie di scambio durante la vita utile del componente nell'impianto.

Funzionamento a flussi paralleli, piastre corrugate in AISI 304 L-316 L-SMO-Titanio-Hastelloy spessore 0.5 mm complete di guarnizioni in elastomero NBR-EPDM-Viton-HNBR non incollate, tiranti in acciaio zincato e telai PN10 e PN16 in acciaio verniciato epossidico. Connessioni di varie tipologie con fi letto o flangia a seconda del modello.

TYPE	A	B	C	D	H	Ø connections
	mm	mm	mm	mm	mm	inches
SP32	180	480	60	357	61,5	1" 1/4
SP32H	200	746	69	654	48,5	1" 1/4
SP50S	330	895	140	640	140	2" DN50
SP50W	330	895	140	640	140	2" DN50
SP65S	396	946	192	700	132	DN65
SP100S	480	1105	225	719	215	DN100
SP100W	480	1105	225	719	215	DN100
SP100H	480	1870	225	1365	270	DN100
SP150S	650	1890	298	1294	326	DN150
SP150W	650	1890	298	1294	326	DN150

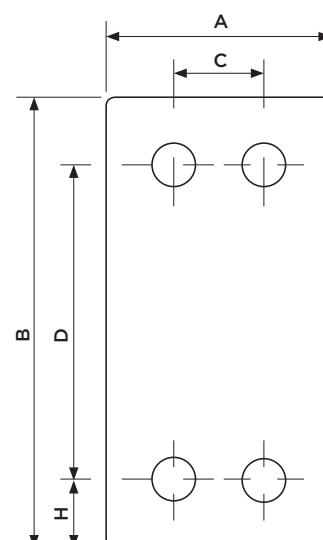

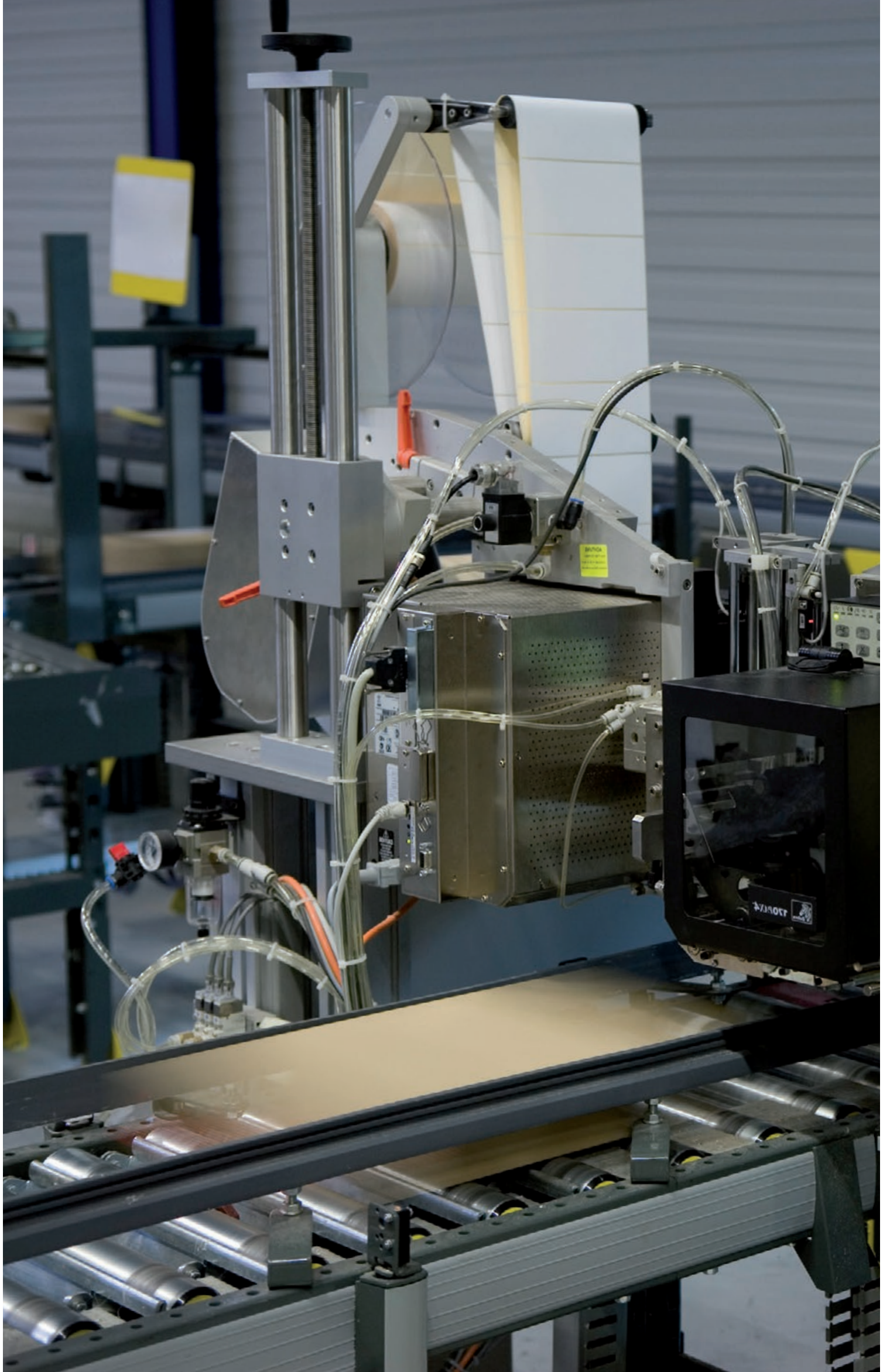

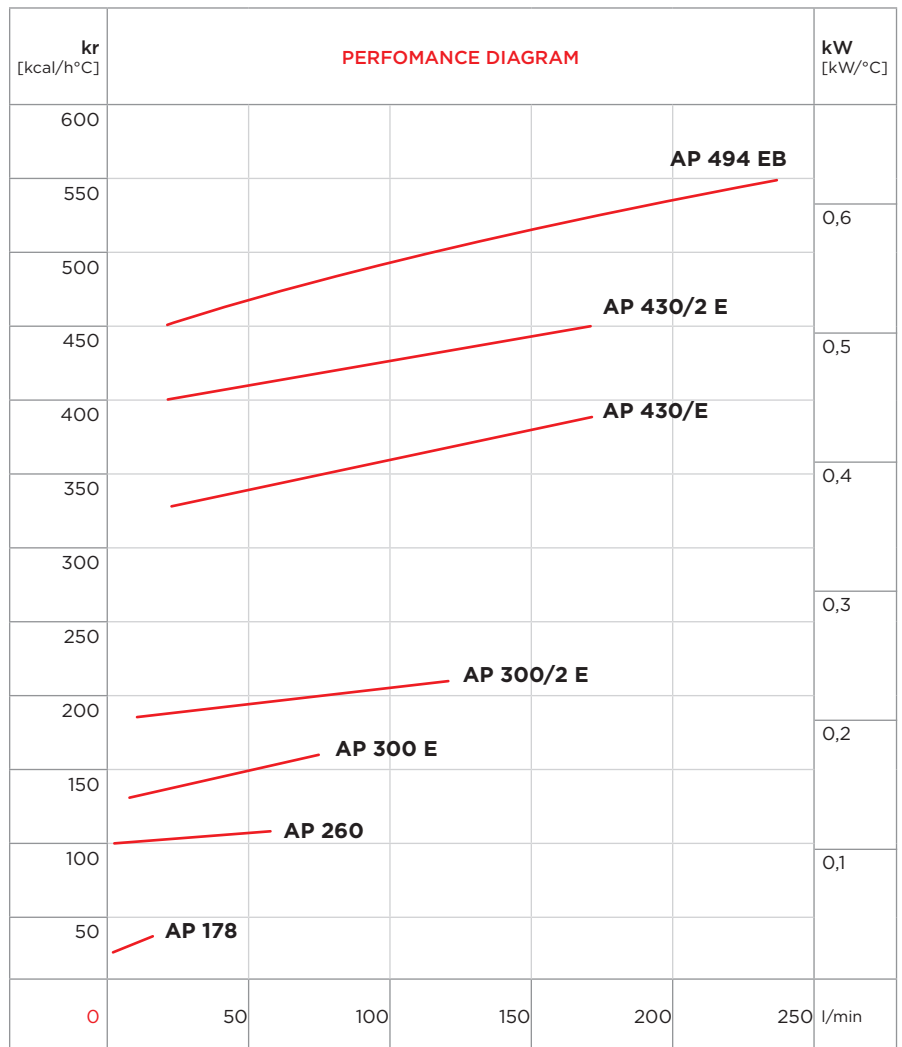
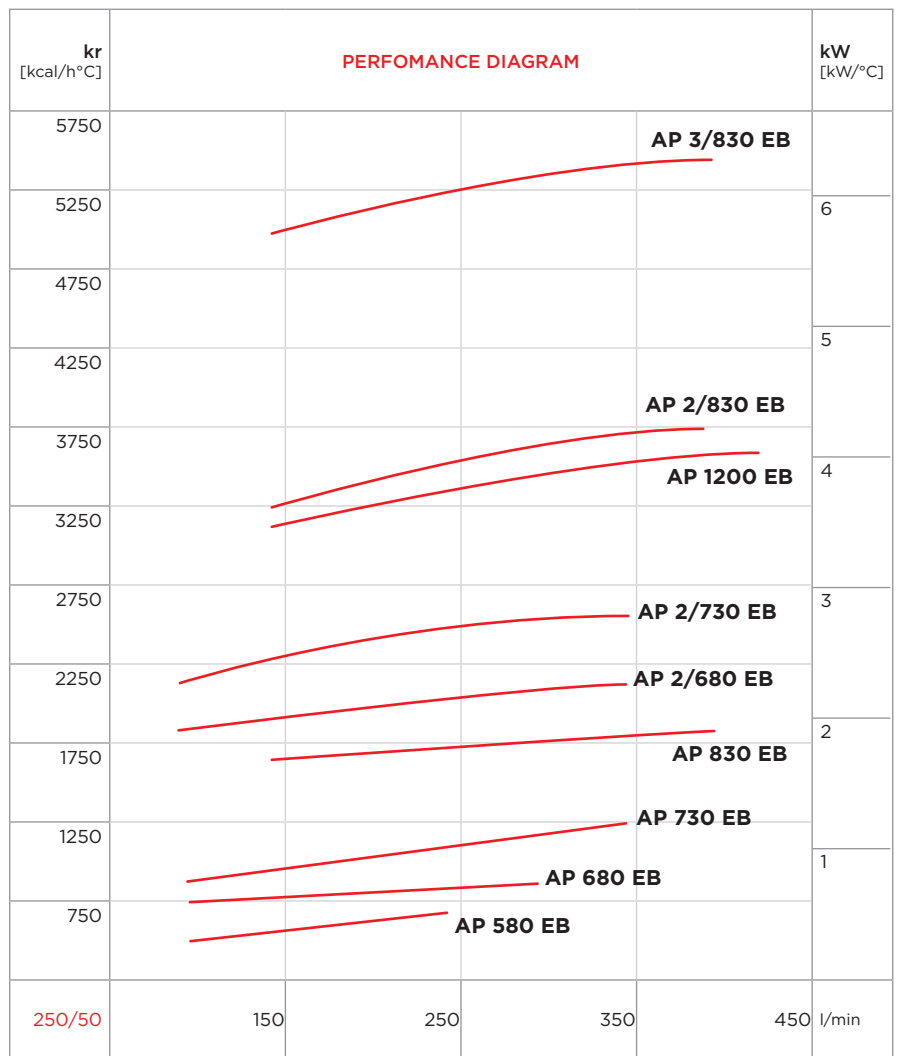

AC MOTOR AIR-OIL HEAT EXCHANGERS

SCAMBIATORI DI CALORE ARIA-OLIO CON VENTILATORE A CORRENTE ALTERNATA



The advantage of using air into the cooling of oleo hydraulic systems has its bases on the following facts:

- There is no need of water
- The system is independent of the connection to the water main
- Lower working costs in comparison with the water-oil exchangers, even if the starting investment is higher
- Possibility to use warm air to heat the room in winter.

The particular structure of the cooling element allows great thermic performances and pressure resistance. **Maximum working static pressure: 20 bar.**

Our technical Department is available to suggest and find the better solution in case of particular working conditions, pressures, frequencies, vibrations, etc.

It is always recommended to assemble in parallel with the exchanger a by-pass valve to avoid extreme counter-pressures, particularly when the machine is started with cold oil. On the contrary, it is not useful to use a check valve as by-pass to protect the exchanger from pressure's peaks, since the inertia of the valve itself is too high in comparison with the speed of the pressure waves that occur into the oleo hydraulic systems.

The flow rates shown in the tables are the ones recommended for the exchanger proper working.

The efficiency curves show the specific exchange capacity in kcal/h°C or in kW/°C according to the different oil rates. To calculate the heat quantity the different exchangers are able to dissipate it is enough to multiply such capacity by the difference between the requested oil temperature and the summer room temperature.

The electric system of these exchangers is already wired.

Starting from the type AP 300, all the exchangers of this series are equipped with an adjustable thermo switch, which allows keeping the oil temperature between 30°C and 90°C, according to the different needs.

Particular attention is paid to the noise of our fans that, working into industrial factories and close to the operators, should have low noise levels but at the same time should have the proper exchange efficiency.

For the right calculation of air-oil heat exchangers, we supply our customers with a calculation program.

The air-oil heat exchangers can be used to cool other kind of fluids, which must be compatible with aluminum and its alloys.

However, for each use, with the exception of oil cooling, we recommend to consult our Technical Department.

Il vantaggio dell'utilizzo dell'aria nel raffreddamento di impianti oleodraulici trova le sue ragioni nei seguenti fattori:

- Non necessità l'utilizzo di acqua
- Indipendenza della macchina dalle tubazioni di allacciamento alla rete idrica
- Inferiore costo di esercizio rispetto agli scambiatori acqua-olio, anche se maggiore è l'investimento iniziale
- Possibilità di utilizzare l'aria calda in uscita per riscaldare l'ambiente nella stagione invernale

*La particolare costruzione del radiatore consente di ottenere notevoli rese termiche e forte resistenza alla pressione; **pressione massima statica di funzionamento: 20 bar.***

Il nostro Ufficio Tecnico è a disposizione per valutare la soluzione più opportuna in presenza di particolari condizioni di lavoro, pressioni, frequenze, vibrazioni, ecc..

È sempre consigliabile montare in parallelo allo scambiatore una valvola di by-pass per evitare eccessive contropressioni soprattutto al momento dell'avviamento della macchina con olio freddo. Non è invece conveniente utilizzare una valvola di ritegno come by-pass per proteggere lo scambiatore dai picchi di pressione in quanto l'inerzia della valvola stessa è troppo alta rispetto alla velocità delle onde di pressione che si sviluppano all'interno dell'olio degli impianti oleoidraulici.

Le portate olio indicate nelle tabelle sono quelle consigliate per il buon funzionamento dello scambiatore.

Le curve di rendimento forniscono la potenzialità di scambio specifica in kcal/h°C o in kW/h°C in funzione della portata olio; per calcolare la quantità di calore che i vari scambiatori sono in grado di disperdere, è sufficiente moltiplicare tale potenzialità per la differenza tra le temperature dell'olio desiderata e dell'aria ambiente massima estiva. Gli scambiatori sono forniti con impianto elettrico già cablato, eseguito secondo la norma europea EN 20204.

Dal tipo AP 300 in su, gli scambiatori sono dotati di termostato regolabile che consente di mantenere l'olio a qualsiasi temperatura tra i 30 e i 90°C, a seconda delle esigenze dell'utilizzatore.

Notevole attenzione è stata posta alla rumorosità dei ventilatori in quanto, dovendo funzionare all'interno di capannoni industriali e quindi a contatto con gli operatori, è molto importante che il loro livello sonoro sia il più basso possibile, compatibilmente con l'esigenza di ottenere rese termiche accettabili.

Per il calcolo degli scambiatori aria-olio è disponibile un programma. Gli scambiatori aria-olio possono essere utilizzati per raffreddare altri tipi di fluidi, a condizione che essi siano compatibili con l'alluminio e le sue leghe.

Consigliamo comunque, per qualsiasi impiego che non sia il raffreddamento dell'olio, di contattare il nostro Ufficio Tecnico.



- Dimensions and technical characteristics are not binding

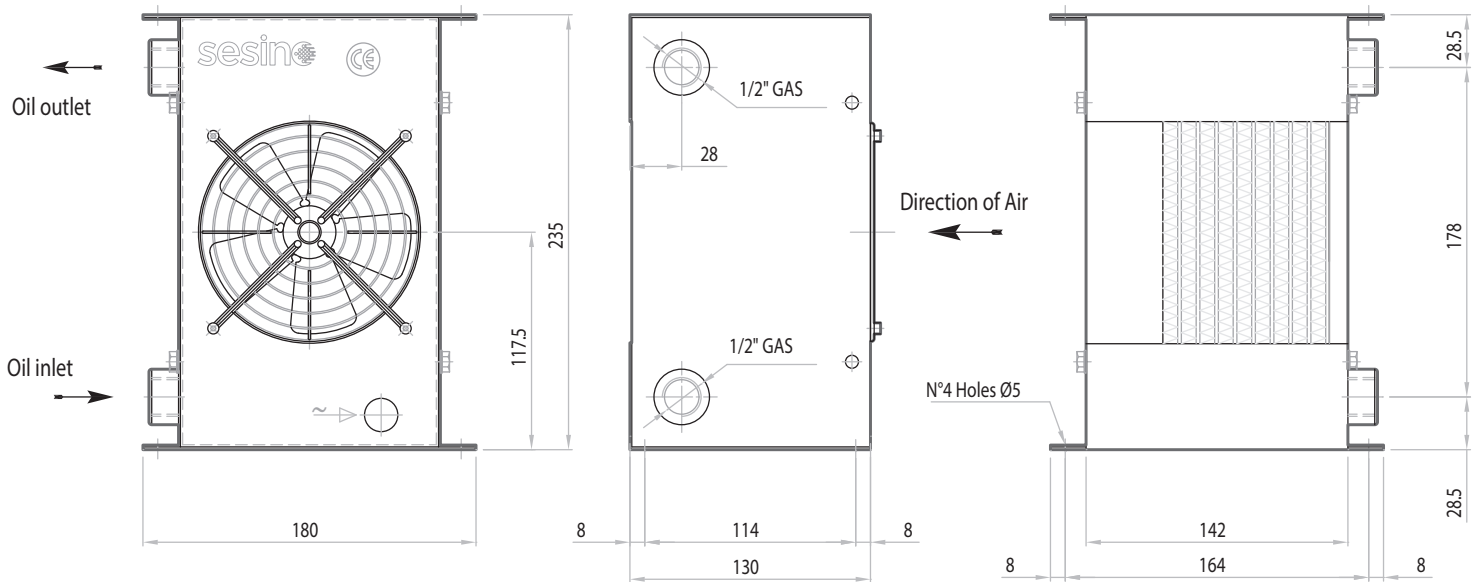

Static working pressure = 20 bar

Test pressure = 35 bar

OIL FLOW	CAPACITY	VOLTAGE	FREQUENCY	POWER	CURRENT	AIR FLOW	PROTECTION	NOISE LEVEL	WEIGHT	Ø FAN
l/min	l	V	hz	W	A	m ³ /h	IP	dB(A)	kg	mm
1-10	0,5	230	50/60	19/18	0,08/0,1	125	54	55	4	125

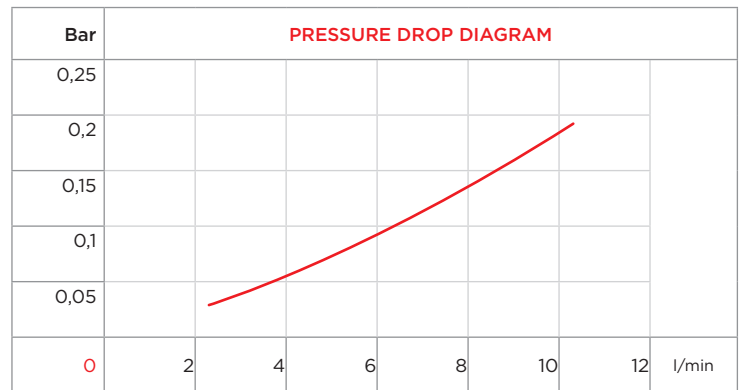
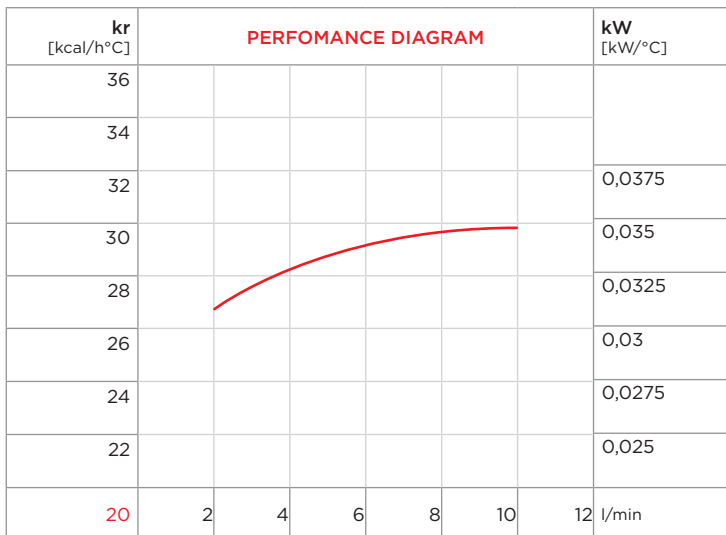

CORRECTION FACTOR

cSt	22	30	46	68	100	150	220
f	0,6	1	1,5	2,3	3,5	5	7

PURCHASE CODES

AP 178 E 230V single-phase	3RAP178
----------------------------	---------

SPARE PARTS

Cooling element	1RO92302
Fan grill	1GPR178
Frame	3CN178.1
Housing	3TL178.1
Electric Fan for 3RAP178	1VNAP178230

AP 260 E

AC MOTOR AIR-OIL HEAT EXCHANGERS
SCAMBIATORI ARIA-OLIO CON VENTILATORE A CORRENTE ALTERNATA



- Dimensions and technical characteristics are not binding

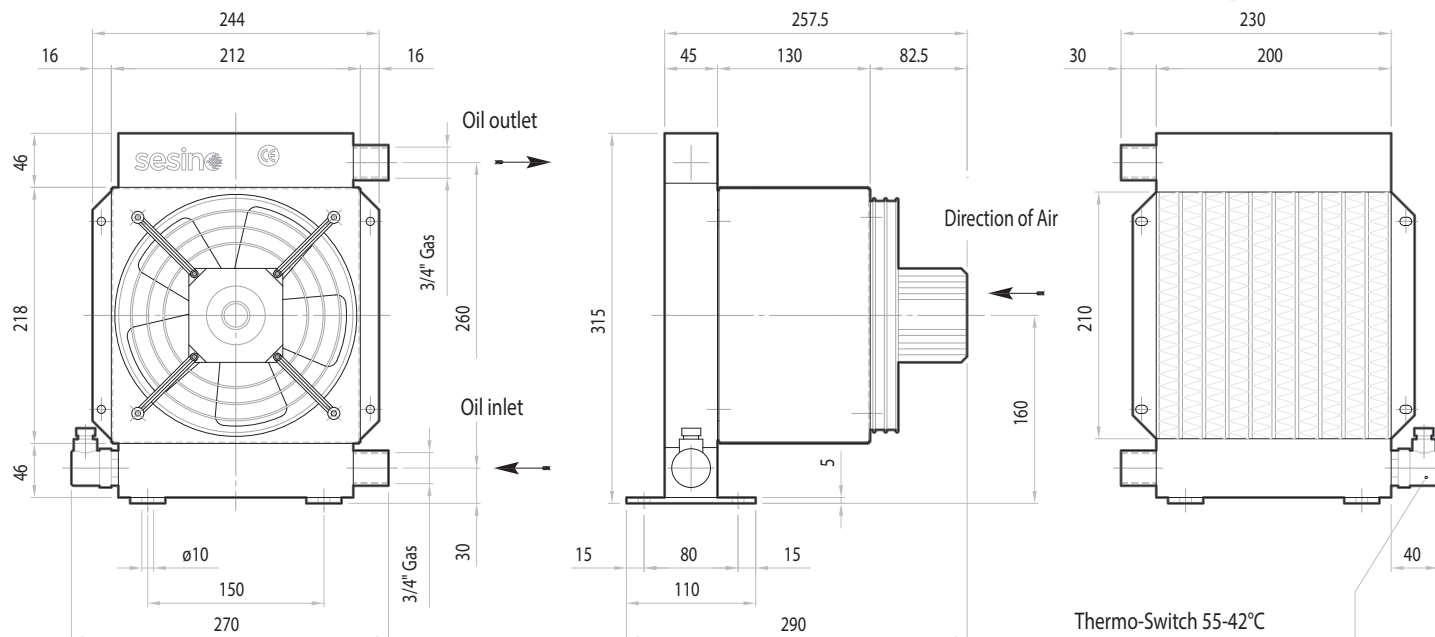

Static working pressure = 20 bar

Test pressure = 35 bar

OIL FLOW	CAPACITY	VOLTAGE	FREQUENCY	POWER	CURRENT	AIR FLOW	PROTECTION	NOISE LEVEL	WEIGHT	ø FAN
l/min	l	V	hz	W	A	m ³ /h	IP	dB(A)	kg	mm
50-60	1,2	230/240	50/60	18/62	0,27	630	54	55	6	200
50-60	1,2	400	50/60	68/70	0,17/0,13	630	54	55	6	200

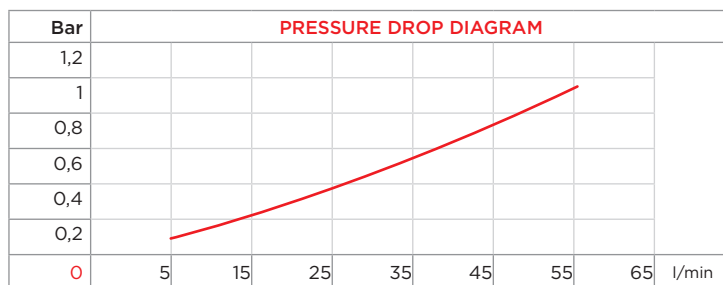
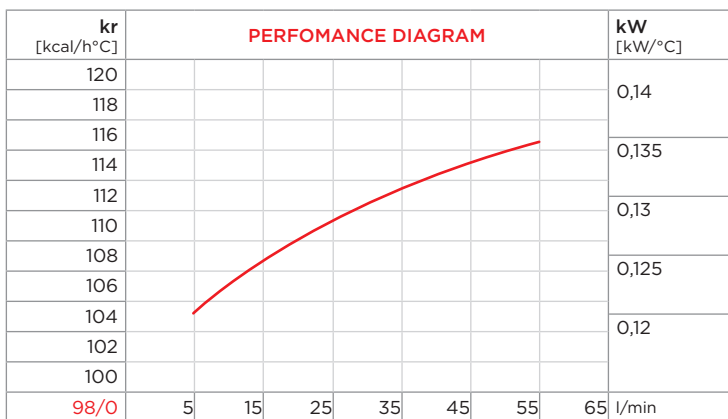

CORRECTION FACTOR

cSt	22	30	46	68	100	150	220
f	0,6	1	1,5	2,3	3,5	5	7

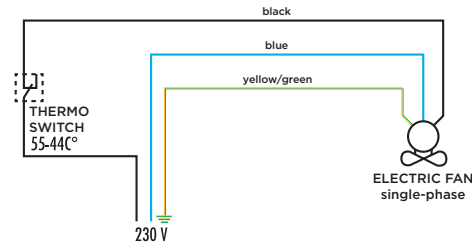

PURCHASE CODES

AP 260 E single-phase	3RAP260T1
AP 260 E three-phase	3RAP26038T1

SPARE PARTS

Cooling element	3RNAP260
Thermo-switch 55-42 IP54	1TRM55-42
Frame	3CNAP260CA.1
Electric Fan for 3RAP260T1	1VNA2E200.1
Electric Fan for 3RAP26038T1	1VNA2D200

AP 300 E

AC MOTOR AIR-OIL HEAT EXCHANGERS
SCAMBIATORI ARIA-OLIO CON VENTILATORE A CORRENTE ALTERNATA



- Dimensions and technical characteristics are not binding

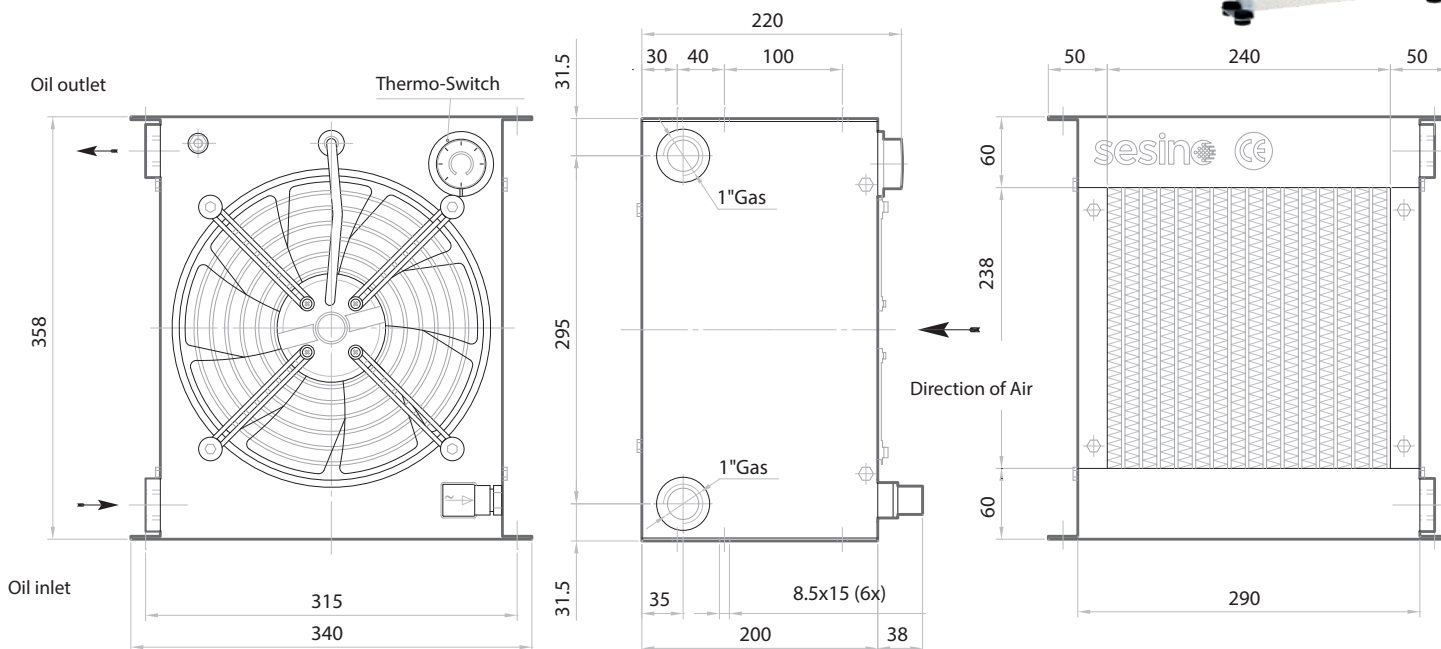

Static working pressure = 20 bar

Test pressure = 35 bar

OIL FLOW	CAPACITY	VOLTAGE	FREQUENCY	POWER	CURRENT	AIR FLOW	PROTECTION	NOISE LEVEL	WEIGHT	Ø FAN
l/min	l	V	hz	W	A	m ³ /h	IP	dB(A)	kg	mm
10-80	2	230	50/60	115/150	0,51/0,66	910	44	74	12	250
10-80	2	400	50/60	100/140	0,2/0,23	950	44	73	12	250

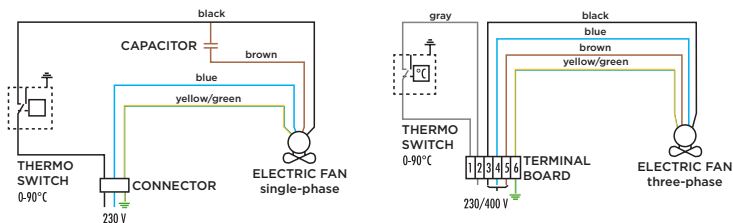
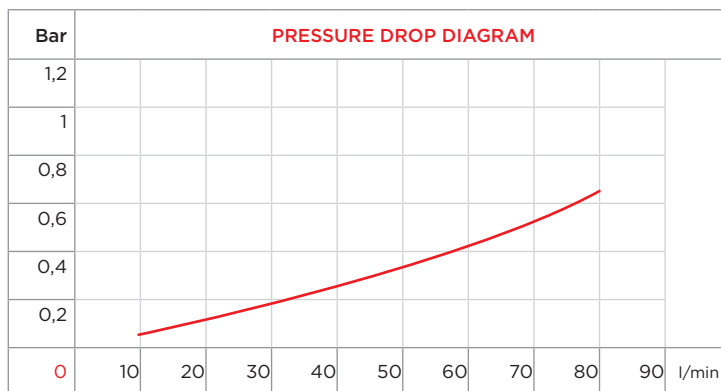
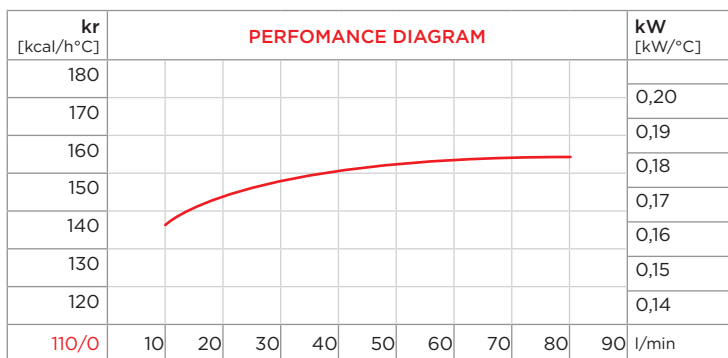

CORRECTION FACTOR							
cSt	22	30	46	68	100	150	220
f	0,6	1	1,5	2,3	3,5	5	7

SPARE PARTS

Cooling element	3RNAP300
Frame	3CNAP300
Housing	1300TLV
Adjustable thermo-switch	1TRM0-90
Electric fan for 3RAP300	1VNA2E250G
Electric fan for 3RAP30038	1VNA2D250.2
Electric junction box for 3RAP30038	1CSDSAREL

PURCHASE CODES

AP 300 E single-phase	3RAP300
AP 300 E three-phase	3RAP30038

AP 300/2 E

AC MOTOR AIR-OIL HEAT EXCHANGERS
SCAMBIATORI ARIA-OLIO CON VENTILATORE A CORRENTE ALTERNATA



- Dimensions and technical characteristics are not binding

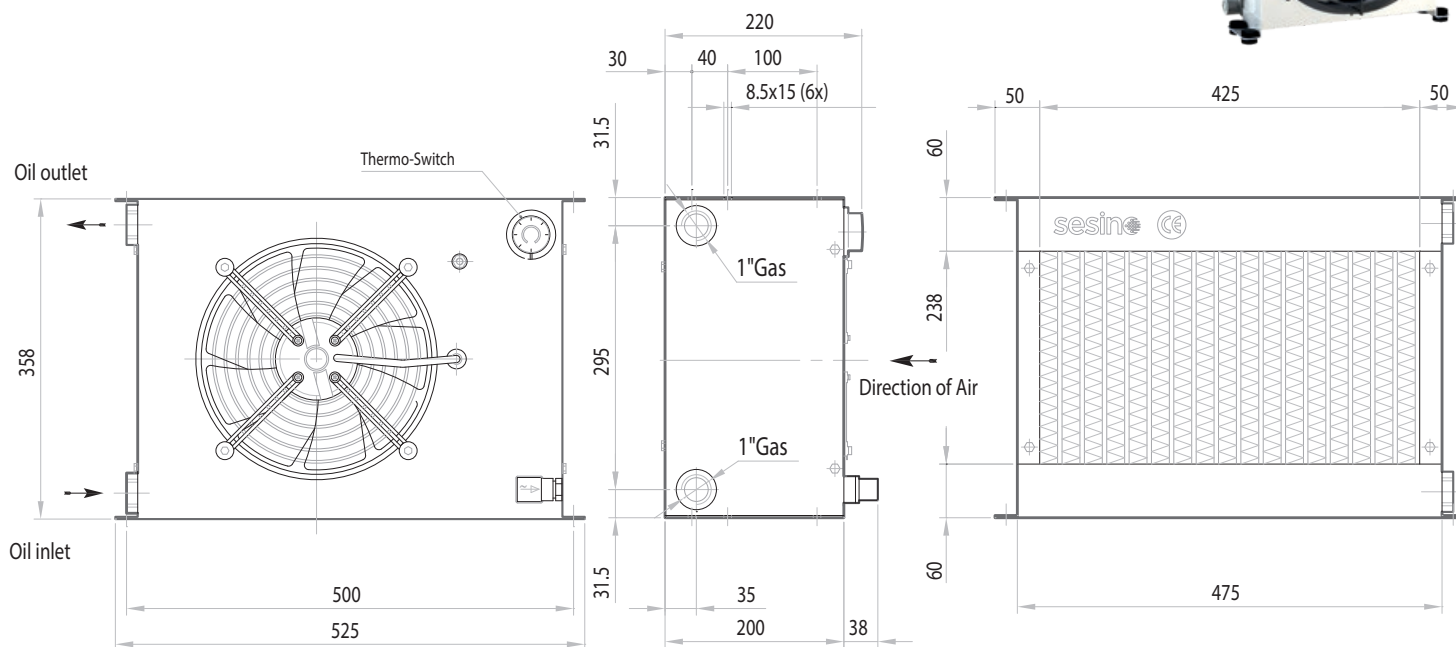

Static working pressure = 20 bar

Test pressure = 35 bar

OIL FLOW	CAPACITY	VOLTAGE	FREQUENCY	POWER	CURRENT	AIR FLOW	PROTECTION	NOISE LEVEL	WEIGHT	ø FAN
l/min	l	V	hz	W	A	m ³ /h	IP	dB(A)	kg	mm
20-160	3,6	230	50/60	115/150	0,51/0,66	1.300	44	75	17	250
20-160	3,6	400	50/60	100/140	0,2/0,23	1.300	44	73	12	250

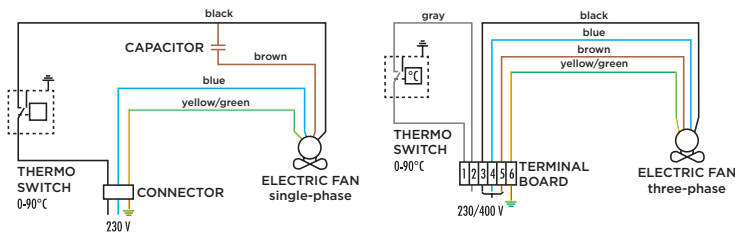
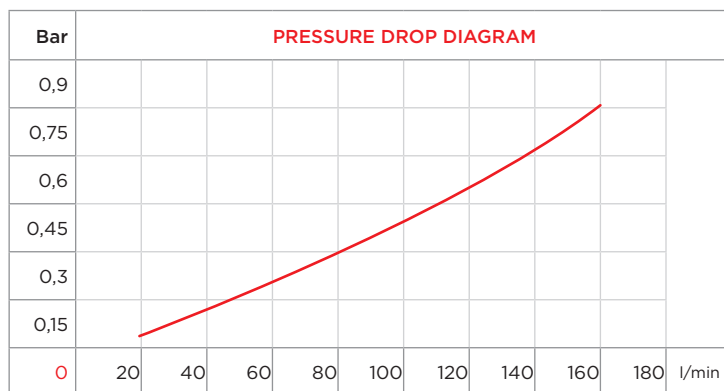
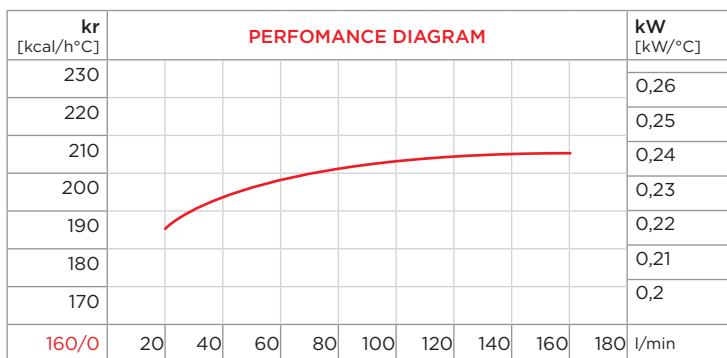

CORRECTION FACTOR							
cSt	22	30	46	68	100	150	220
f	0,6	1	1,5	2,3	3,5	5	7

SPARE PARTS

Cooling element	3RNAP302
Frame	3CNAP302
Housing	1302TLV
Adjustable thermo-switch	1TRM0-90
Electric fan for 3RAP302	1VNA2E250G
Electric fan for 3RAP30238	1VNA2D250.2
Electric junction box for 3RAP30038	1CSSDSAREL

PURCHASE CODES

AP 300 2/E single-phase	3RAP302
AP 300 2/E three-phase	3RAP30238

AP 430 E

AC MOTOR AIR-OIL HEAT EXCHANGERS
SCAMBIATORI ARIA-OLIO CON VENTILATORE A CORRENTE ALTERNATA



- Dimensions and technical characteristics are not binding

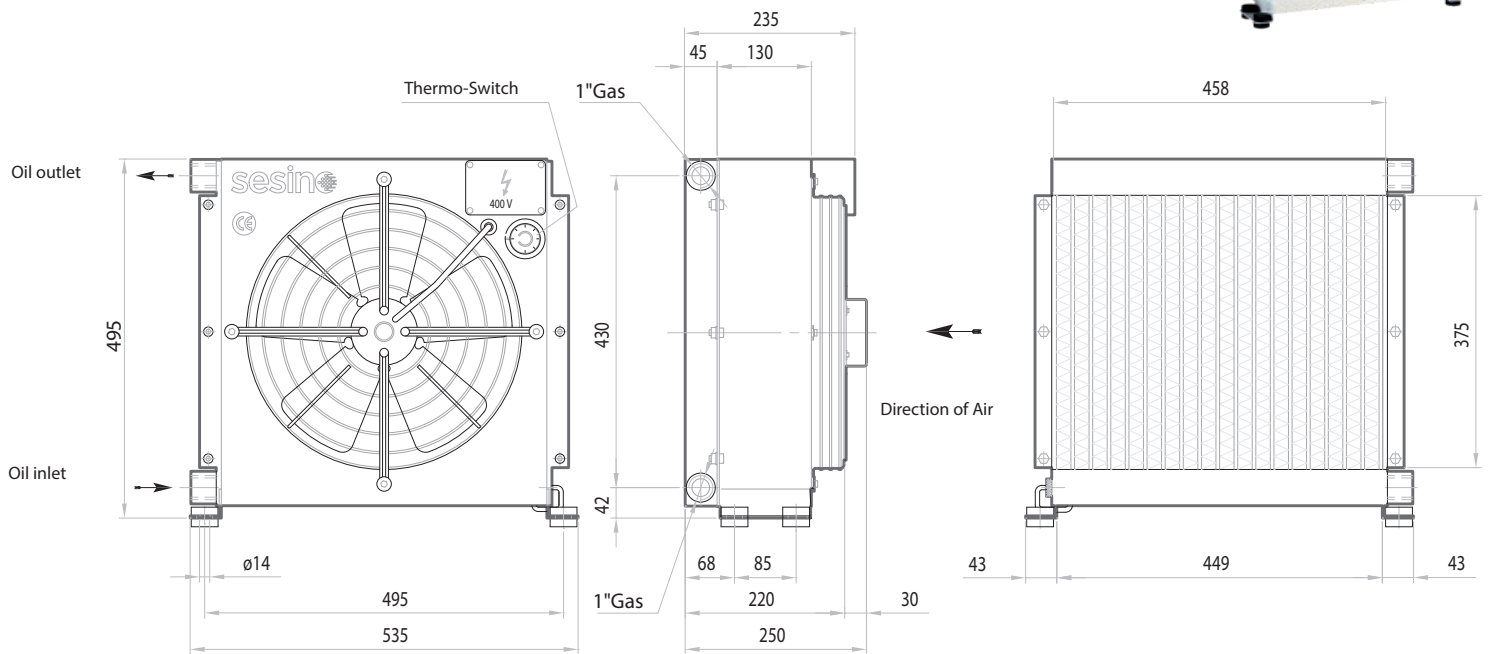

Static working pressure = 20 bar

Test pressure = 35 bar

OIL FLOW	CAPACITY	VOLTAGE	FREQUENCY	POWER	CURRENT	AIR FLOW	PROTECTION	NOISE LEVEL	WEIGHT	ϕ FAN
l/min	l	V	hz	W	A	m ³ /h	IP	dB(A)	kg	mm
30-180	3,6	Δ 230 Y 400	50	100/170	0,52/0,30	2.750	55	73	18	350
30-180	3,6	Δ 265 Y 480	60	100/180	0,50/0,29	2.750	55	73	18	350

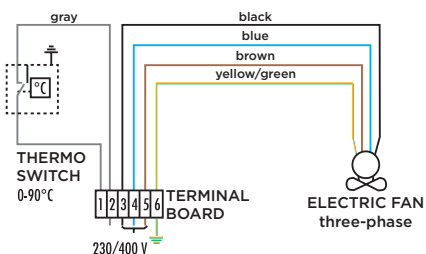
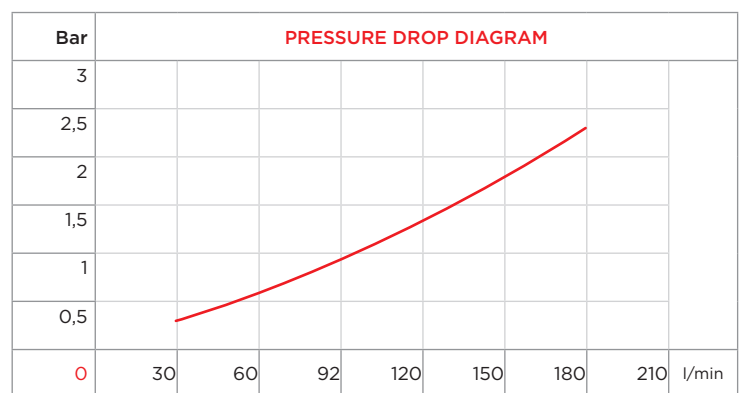
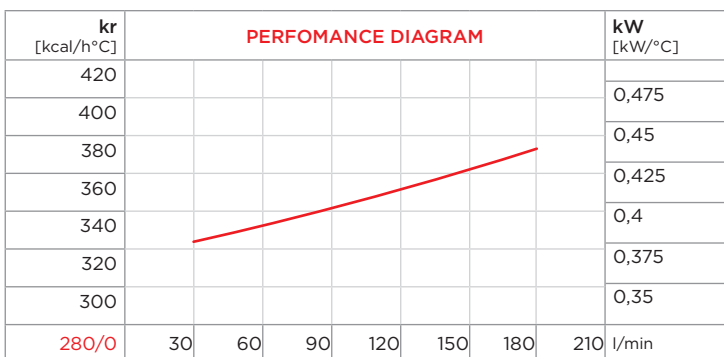

CORRECTION FACTOR							
cSt	22	30	46	68	100	150	220
f	0,6	1	1,5	2,3	3,5	5	7

PURCHASE CODES

AP 430 E single-phase	3RAP430
-----------------------	---------

SPARE PARTS

Cooling element	3RNAP430E
Frame	1430CNV
Adjustable thermo-switch	1TRMO-90
Shock isolating mounting (4 pcs)	3KIT4511
Electric Fan for 3RAP430	1VNELCO43038DV1
Electric junction box for 3RAP430	1CSSDSAREL

AP 430/2 E

AC MOTOR AIR-OIL HEAT EXCHANGERS
SCAMBIATORI ARIA-OLIO CON VENTILATORE A CORRENTE ALTERNATA



- Dimensions and technical characteristics are not binding

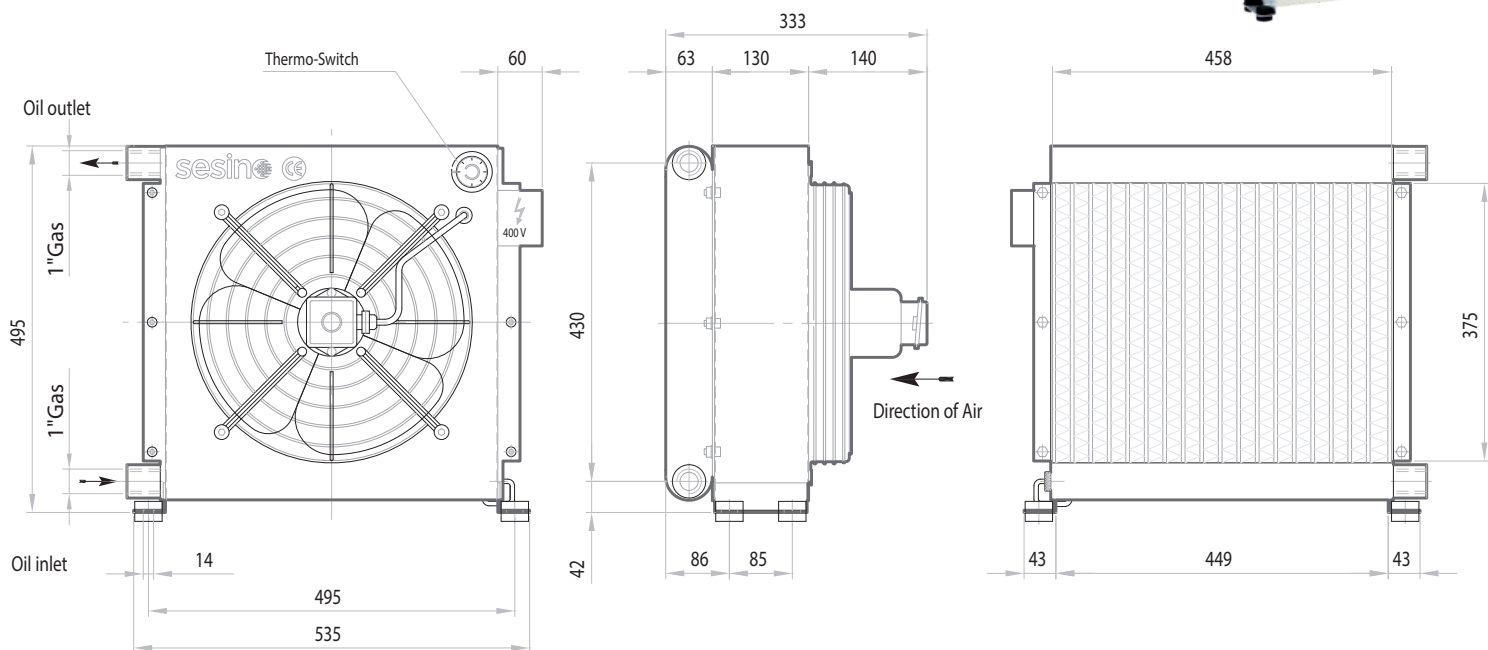

Static working pressure = 20 bar

Test pressure = 35 bar

OIL FLOW	CAPACITY	VOLTAGE	FREQUENCY	POWER	CURRENT	AIR FLOW	PROTECTION	NOISE LEVEL	WEIGHT	Ø FAN
l/min	l	V	hz	W	A	m ³ /h	IP	dB(A)	kg	mm
30-180	5,5	Δ 230 Y 400	50	95/190	0,60/0,35	2.700	55	72	24	400
30-180	5,5	Δ 265 Y 480	60	130/250	0,69/0,40	3.500	55	72	24	400

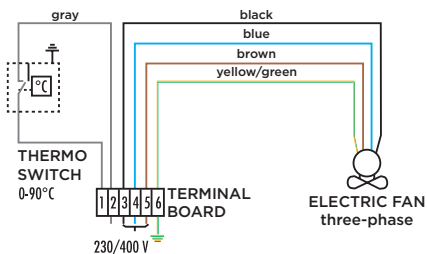
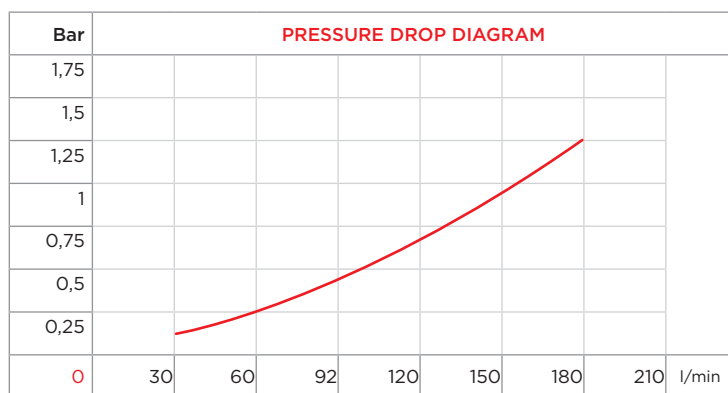
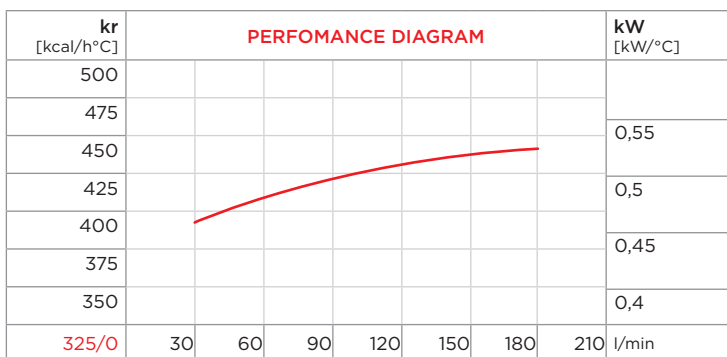

		CORRECTION FACTOR						
cSt	22	30	46	68	100	150	220	
f	0,6	1	1,5	2,3	3,5	5	7	

SPARE PARTS

Cooling element	3RNAP432E
Frame	1432CNV
Adjustable thermo-switch	1TRMO-90
Shock isolating mounting (4 pcs)	3KIT4511
Electric Fan for 3RAP432.1	1VNELCO43238DV2
Electric junction box for 3RAP432.1	1CSSDSAREL

PURCHASE CODES

AP 430 2/E three-phase	3RAP432.1
------------------------	-----------

AP 494 EB

AC MOTOR AIR-OIL HEAT EXCHANGERS
SCAMBIATORI ARIA-OLIO CON VENTILATORE A CORRENTE ALTERNATA



- Dimensions and technical characteristics are not binding

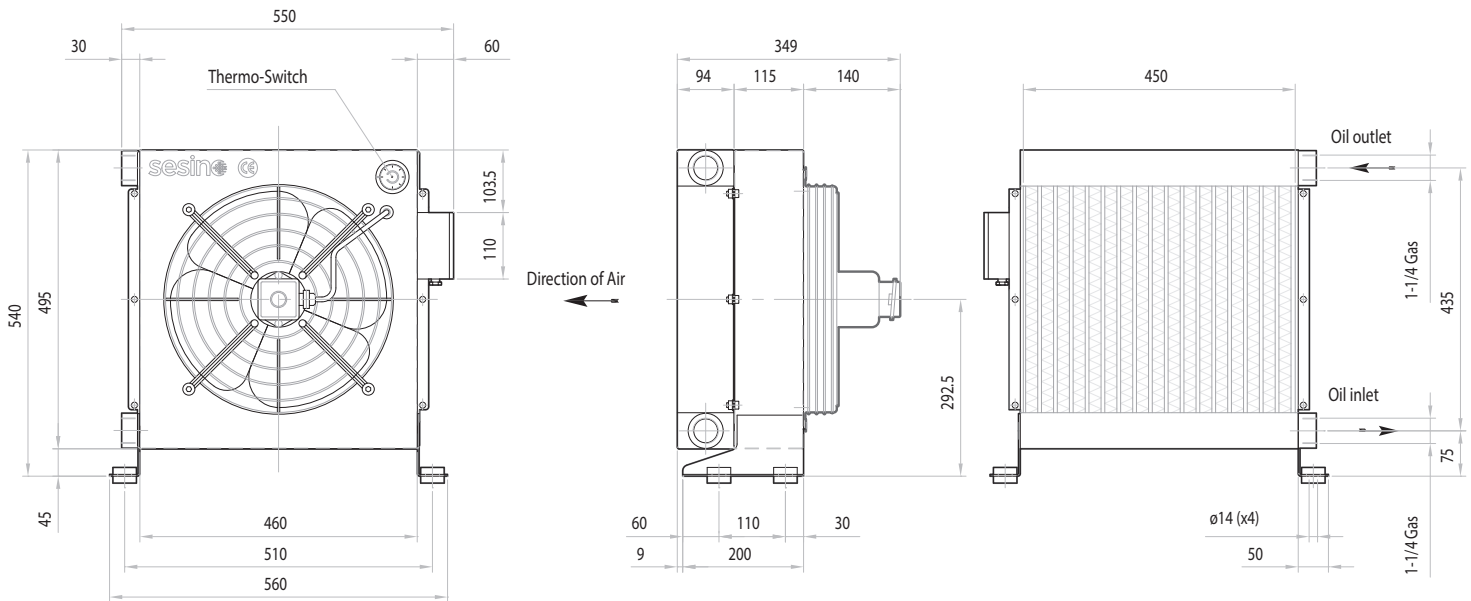

Static working pressure = 20 bar

Test pressure = 35 bar

OIL FLOW	CAPACITY	VOLTAGE	FREQUENCY	POWER	CURRENT	AIR FLOW	PROTECTION	NOISE LEVEL	WEIGHT	ø FAN
l/min	l	V	hz	W	A	m ³ /h	IP	dB(A)	kg	mm
30-240	8	Δ 230 Y 400	50	95/190	0,60/035	2.750	54	72	28	400
30-240	8	Δ 265 Y 480	60	130/250	0,69/0,40	3.300	54	73	28	400

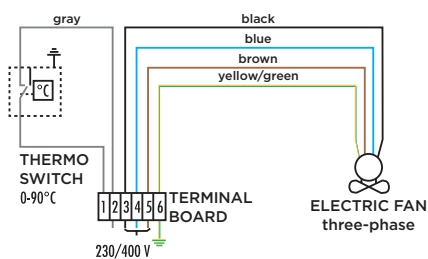
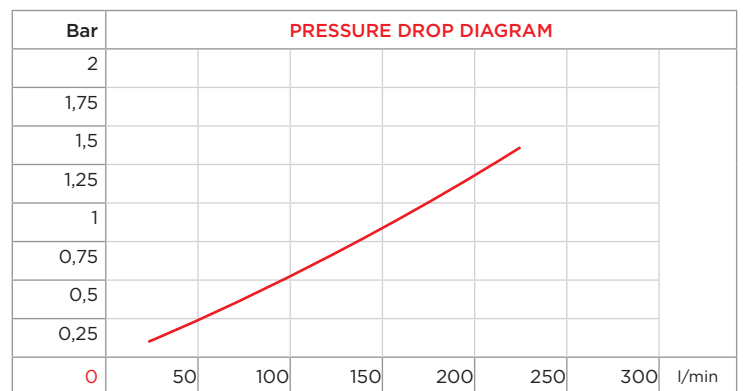
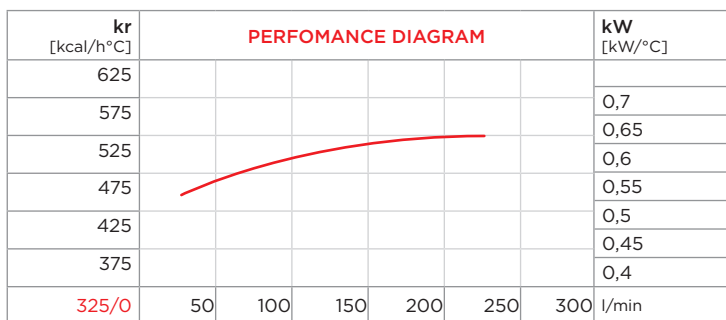

CORRECTION FACTOR							
cSt	22	30	46	68	100	150	220
f	0,6	1	1,5	2,3	3,5	5	7

PURCHASE CODES

AP 494 EB three-phase	3RAP494EB
-----------------------	------------------

SPARE PARTS

Adjustable thermo-switch	1TRMO-90
Shock isolating mounting (4 pcs)	3KIT4135
Electric junction box for	1CSSDSAREL
Frame	3CNAP494EB.1
Cooling element	1RO993321
Electric fan	1VNELCO4328DV2

AP 580 EB

AC MOTOR AIR-OIL HEAT EXCHANGERS
SCAMBIATORI ARIA-OLIO CON VENTILATORE A CORRENTE ALTERNATA



- Dimensions and technical characteristics are not binding

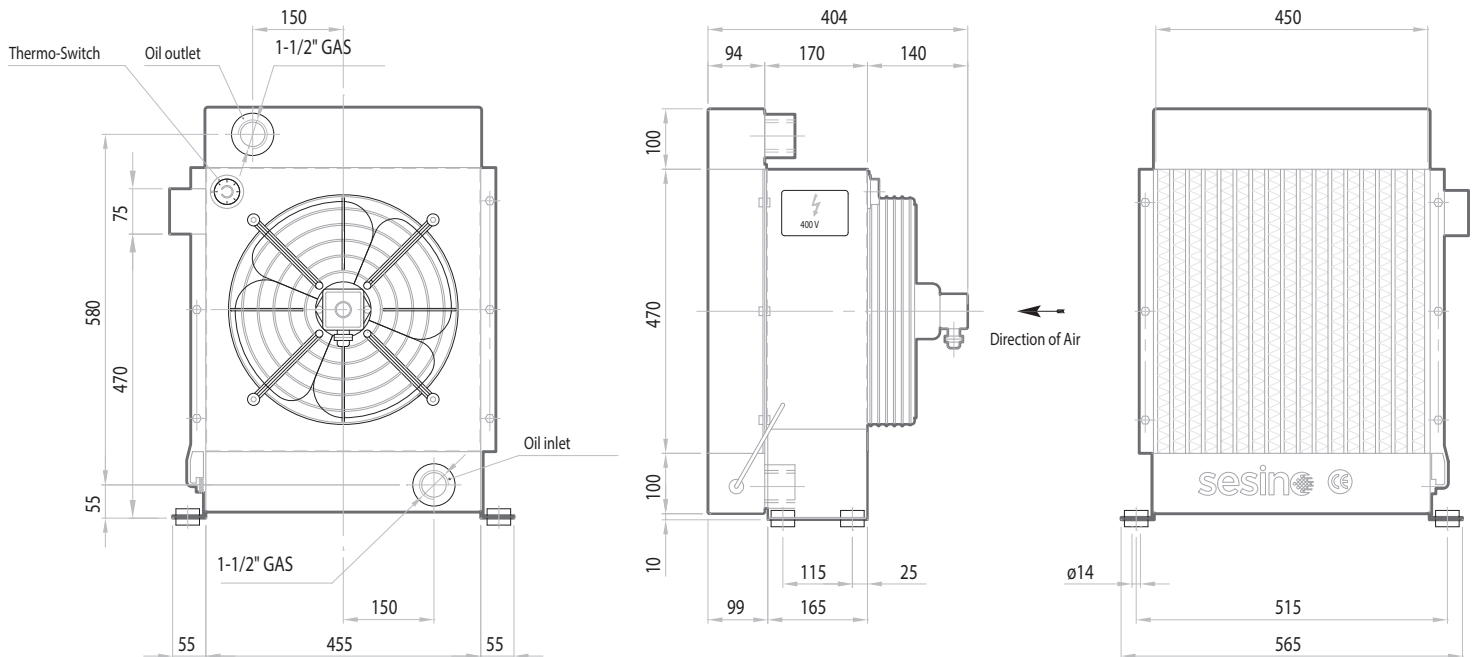

Static working pressure = 20 bar

Test pressure = 35 bar

OIL FLOW	CAPACITY	VOLTAGE	FREQUENCY	POWER	CURRENT	AIR FLOW	PROTECTION	NOISE LEVEL	WEIGHT	Ø FAN
l/min	l	V	hz	W	A	m ³ /h	IP	dB(A)	kg	mm
100-250	11,5	Δ 230 Y 400	50	95/190	0,60/0,35	3.500	55	72	40	400
100-250	11,5	Δ 265 Y 480	60	130/250	0,69/0,40	4.800	55	72	40	400

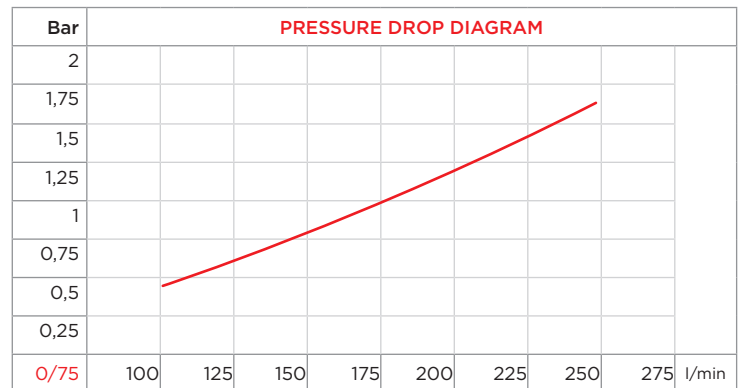
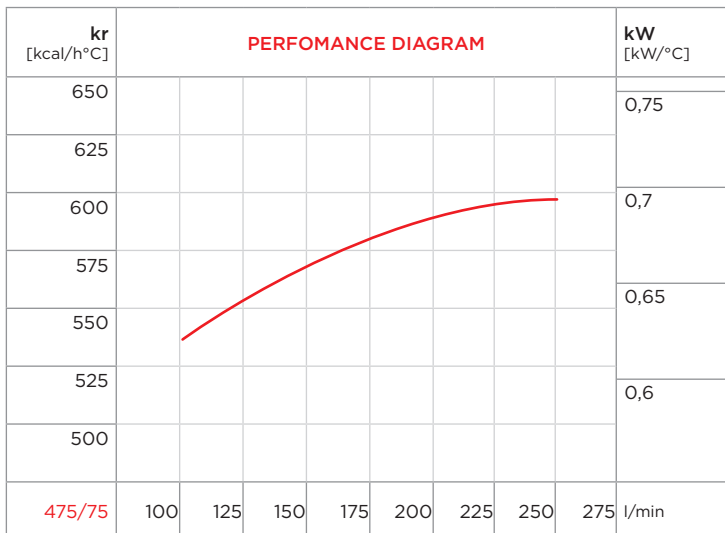

CORRECTION FACTOR

cSt	22	30	46	68	100	150	220
f	0,6	1	1,5	2,3	3,5	5	7

SPARE PARTS

Adjustable thermo-switch	1TRM0-90
Shock isolating mounting (4 pcs)	3KIT4135
Electric junction box for	1CSSDSAREL
Cooling element	3RNAP580E
Electric fan	1VNELCO4328DV2
Frame	3CNAP580EB.1

PURCHASE CODES

AP 580 EB three-phase	3RAP580EB
-----------------------	------------------

AP 680 EB

AC MOTOR AIR-OIL HEAT EXCHANGERS
SCAMBIATORI ARIA-OLIO CON VENTILATORE A CORRENTE ALTERNATA



- Dimensions and technical characteristics are not binding

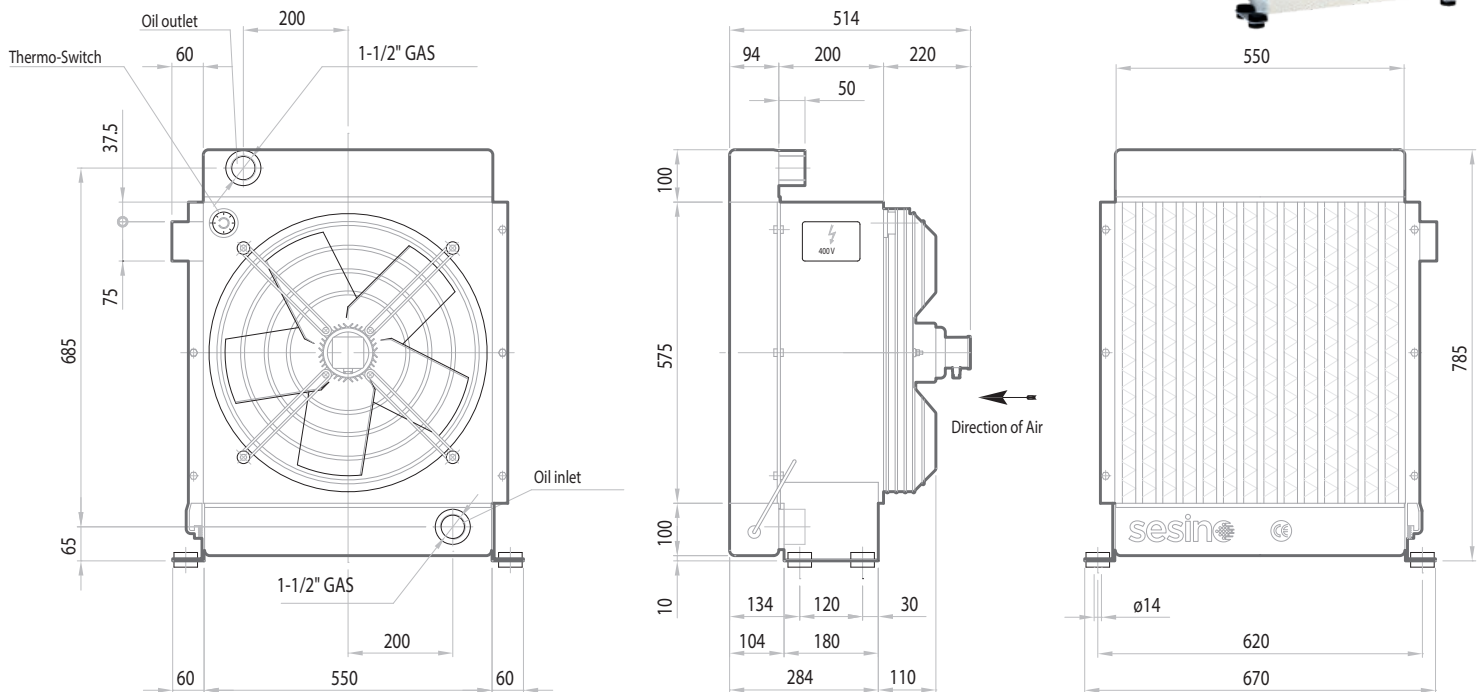

Static working pressure = 20 bar

Test pressure = 35 bar

OIL FLOW	CAPACITY	VOLTAGE	FREQUENCY	POWER	CURRENT	AIR FLOW	PROTECTION	NOISE LEVEL	WEIGHT	ϕ FAN
l/min	l	V	hz	W	A	m ³ /h	IP	dB(A)	kg	mm
100-300	15	230/400	50	598	2,19	6.300	55	72	62	500
100-300	15	266/460	60	941	2,63	8.800	55	75	62	500

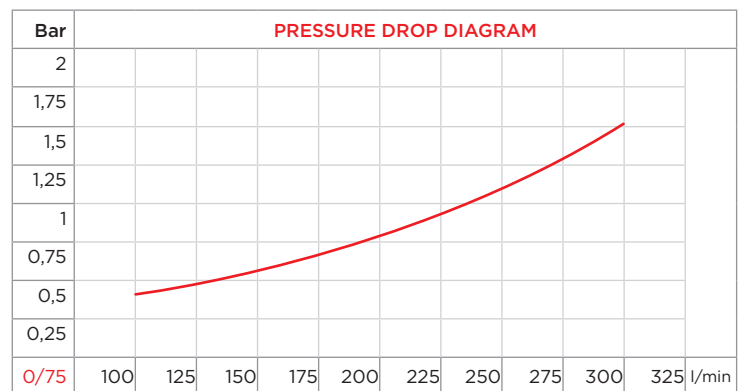
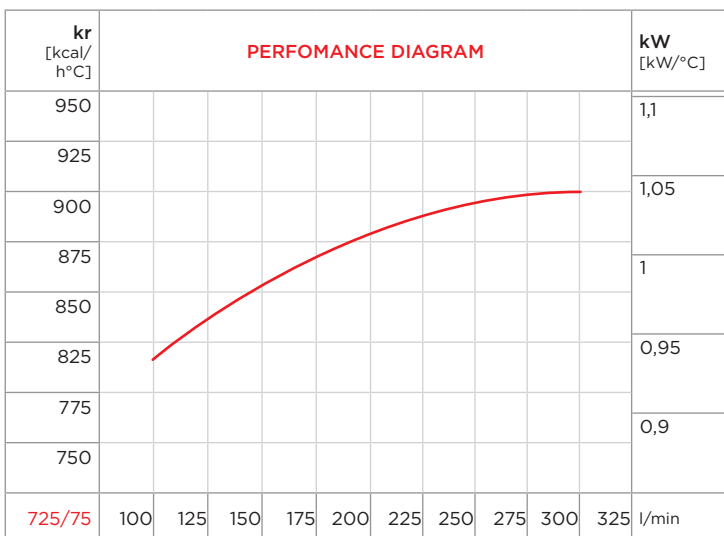

CORRECTION FACTOR

cSt	22	30	46	68	100	150	220
f	0,6	1	1,5	2,3	3,5	5	7

PURCHASE CODES

AP 680 EB three-phase	3RAP680EB
-----------------------	------------------

SPARE PARTS

Adjustable thermo-switch	1TRM0-90
Shock isolating mounting (4 pcs)	3KIT4135
Electric junction box	1CSSDSAREL
Cooling element	3RNAP680E
Electric fan	1VNAP680DV
Frame	3CNAP680EB.1



- Dimensions and technical characteristics are not binding

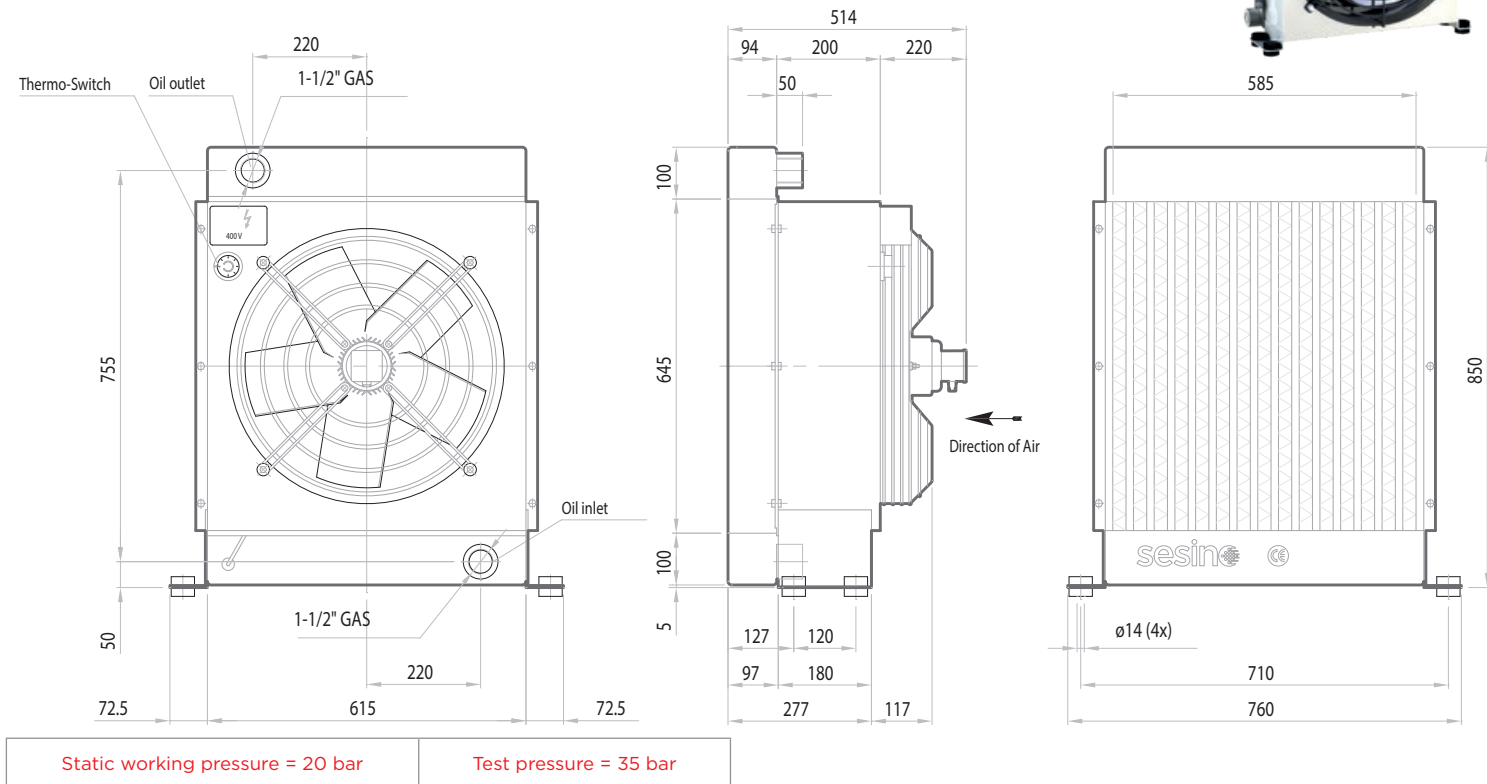

Static working pressure = 20 bar

Test pressure = 35 bar

OIL FLOW	CAPACITY	VOLTAGE	FREQUENCY	POWER	CURRENT	AIR FLOW	PROTECTION	NOISE LEVEL	WEIGHT	ø FAN
l/min	l	V	hz	W	A	m ³ /h	IP	dB(A)	kg	mm
100-300	15	230/400	50	598	2,19	6.300	55	72	62	500
100-300	15	266/460	60	941	2,63	8.800	55	75	62	500

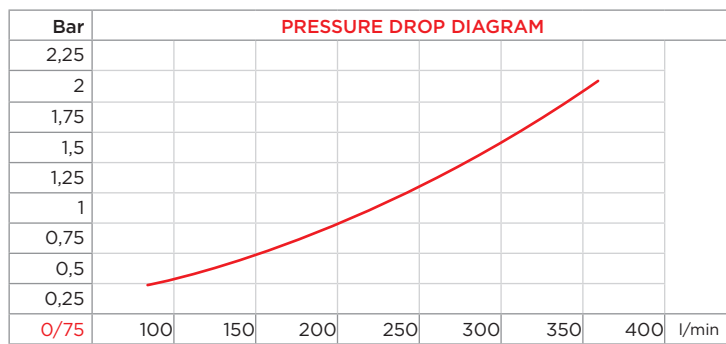
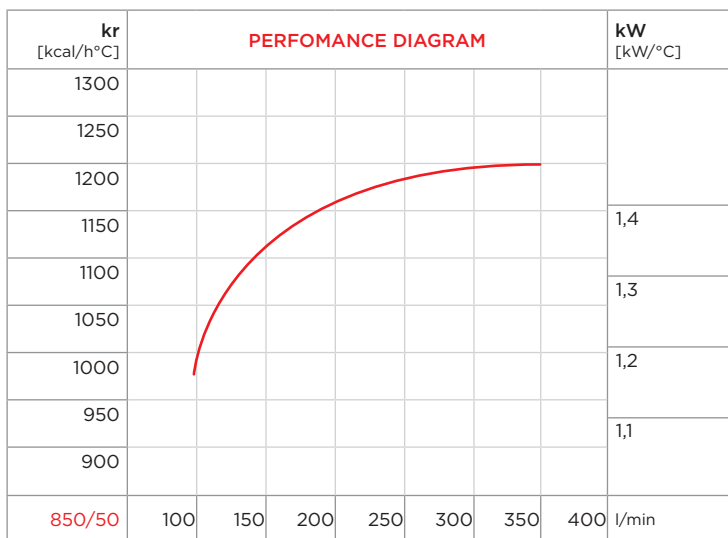

CORRECTION FACTOR							
cSt	22	30	46	68	100	150	220
f	0,6	1	1,5	2,3	3,5	5	7

PURCHASE CODES

AP 730 EB three-phase	3RAP730EB
-----------------------	------------------

SPARE PARTS

Adjustable thermo-switch	1TRMO-90
Shock isolating mounting (4 pcs)	3KIT4232
Electric junction box for	1CSSDSAREL
Cooling element	3RNAP730E
Electric fan	1VNAP680DV
Frame	3CNAP730EB.1

AP 830 EB

AC MOTOR AIR-OIL HEAT EXCHANGERS
SCAMBIATORI ARIA-OLIO CON VENTILATORE A CORRENTE ALTERNATA



- Dimensions and technical characteristics are not binding

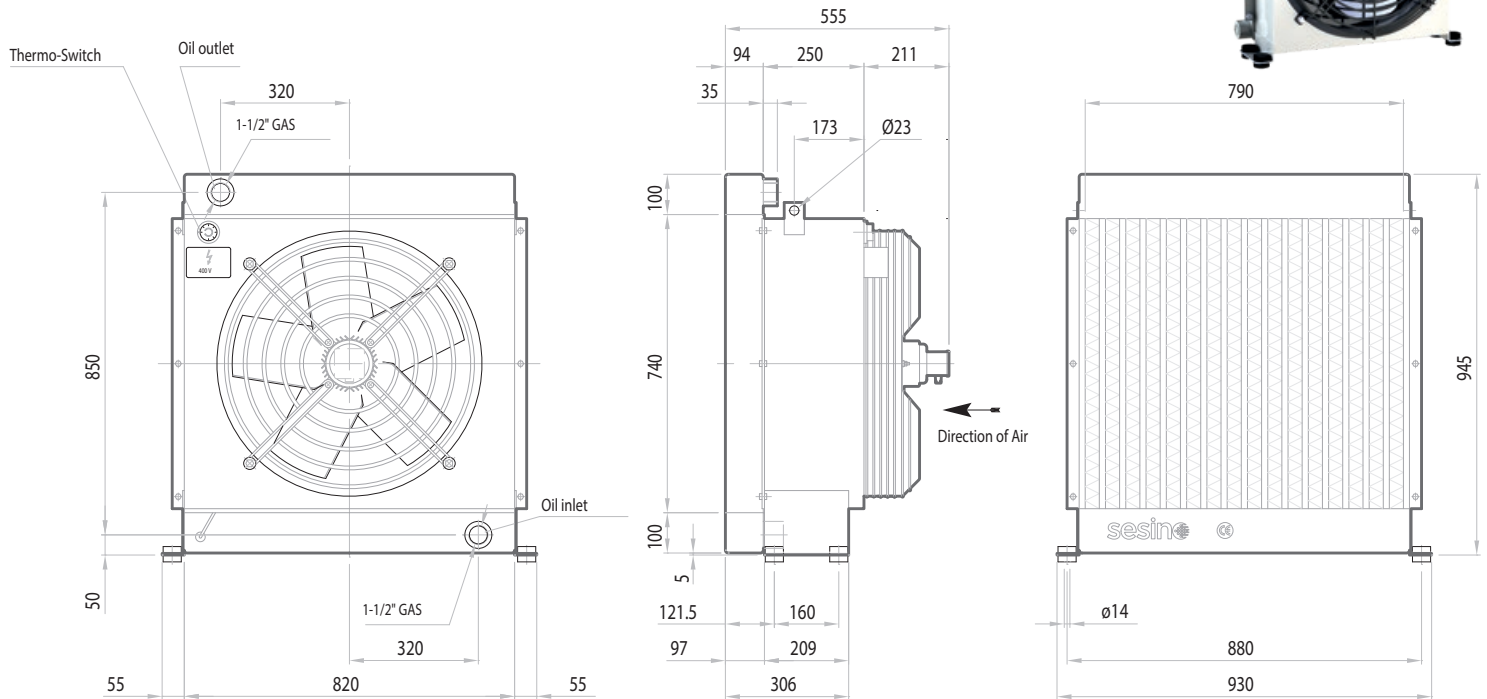

Static working pressure = 20 bar Test pressure = 35 bar

OIL FLOW	CAPACITY	VOLTAGE	FREQUENCY	POWER	CURRENT	AIR FLOW	PROTECTION	NOISE LEVEL	WEIGHT	Ø FAN
l/min	l	V	hz	W	A	m ³ /h	IP	dB(A)	kg	mm
150-400	20	400	50	719	1,42	9.500	55	73	83	560
150-400	20	460	60	1132	1,81	11.500	55	75	83	560

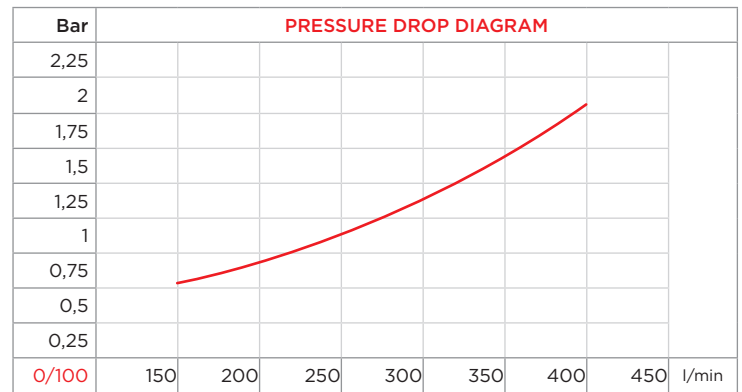
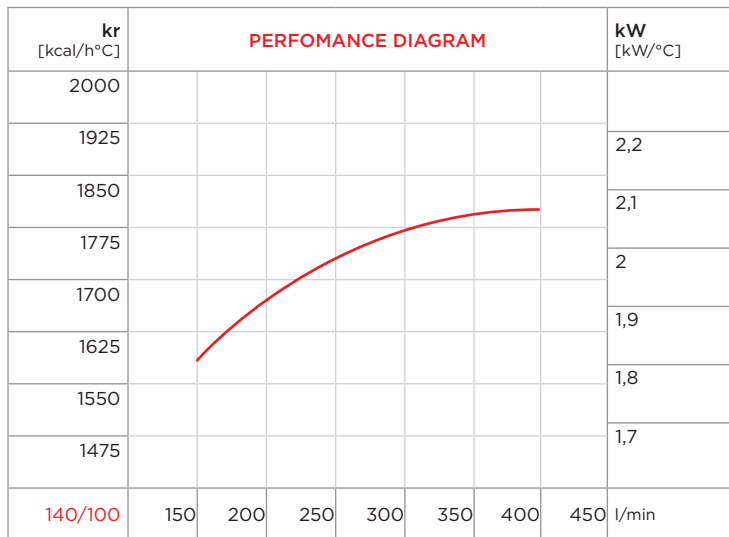

cSt	22	30	46	68	100	150	220
f	0,6	1	1,5	2,3	3,5	5	7

PURCHASE CODES

AP 830 EB three-phase	3RAP830EB
-----------------------	------------------

SPARE PARTS

Adjustable thermo-switch	1TRM0-90
Shock isolating mounting (4 pcs)	3KIT4232
Electric junction box for	1CSSDSAREL
Cooling element	3RNAP830E
Electric fan	1VNAP830DV
Frame	3CNAP830EB.1

AP 1200 EB

AC MOTOR AIR-OIL HEAT EXCHANGERS
SCAMBIATORI ARIA-OLIO CON VENTILATORE A CORRENTE ALTERNATA



- Dimensions and technical characteristics are not binding

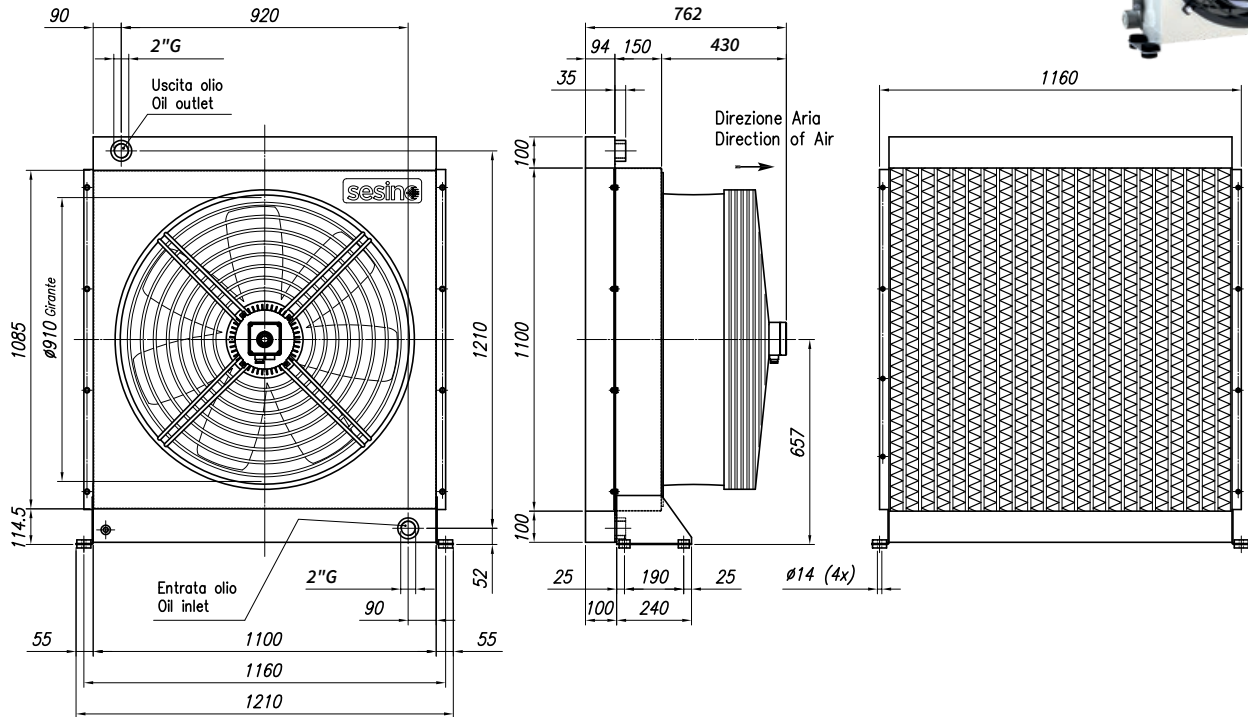

Static working pressure = 20 bar

Test pressure = 35 bar

OIL FLOW	CAPACITY	VOLTAGE	FREQUENCY	POWER	CURRENT	AIR FLOW	PROTECTION	NOISE LEVEL	WEIGHT	φ FAN
l/min	l	V	hz	W	A	m ³ /h	IP	dB(A)	kg	mm
250-150	35	Δ-Y	50	2414(Δ) /	4,6(Δ) / 2,44 (Y)	14.000	54	70	135	910

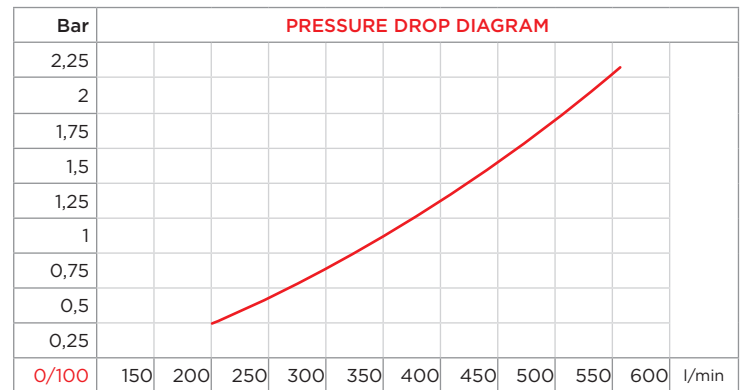
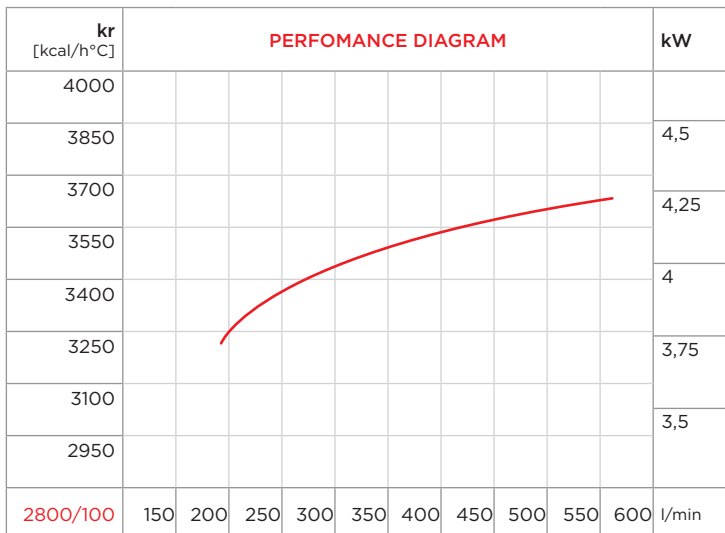

CORRECTION FACTOR							
cSt	22	30	46	68	100	150	220
f	0,6	1	1,5	2,3	3,5	5	7

PURCHASE CODES

AP 1200 EB three-phase	3RAP1200EB
------------------------	-------------------

SPARE PARTS

Frame	3CNEO08586.1
Shock isolating mounting (4 pcs)	3KIT4232
Cooling element	1RO08423
Electric fan	1VNEO08586.2

AP 2/680 EB

AC MOTOR AIR-OIL HEAT EXCHANGERS
SCAMBIATORI ARIA-OLIO CON VENTILATORE A CORRENTE ALTERNATA



- Dimensions and technical characteristics are not binding

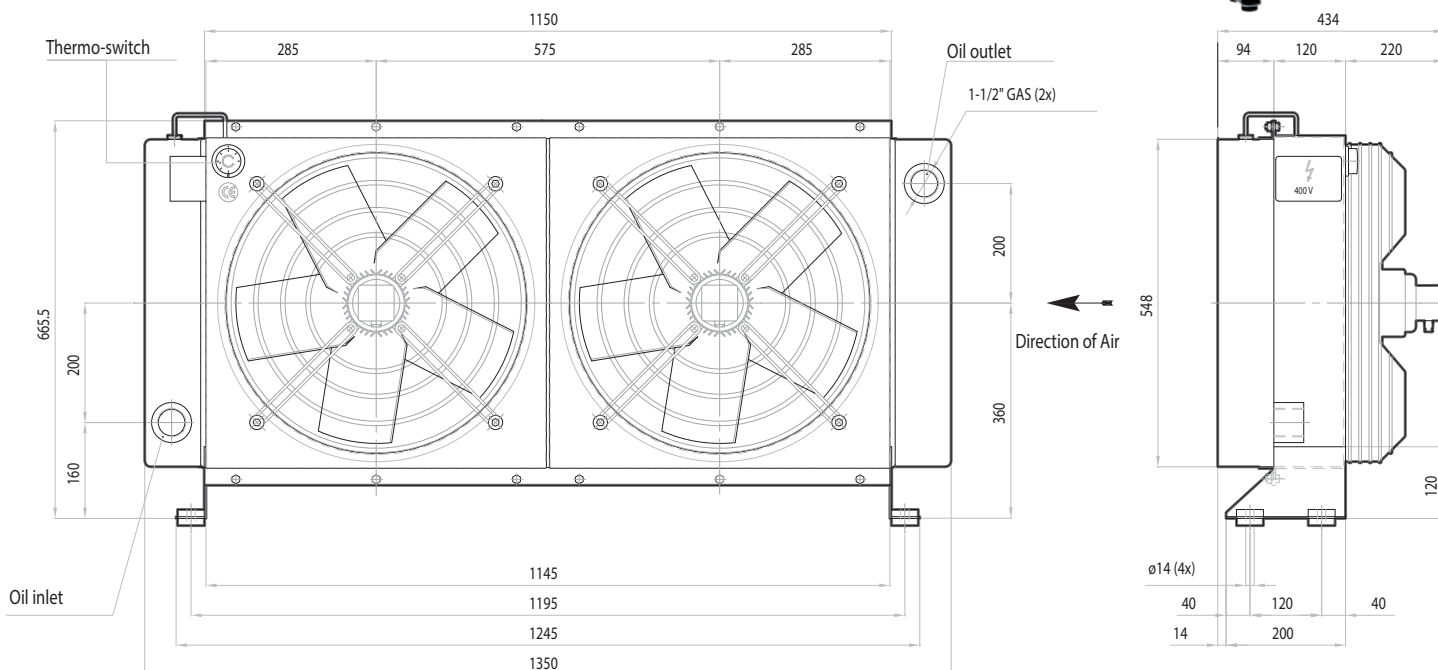

Static working pressure = 20 bar

Test pressure = 35 bar

OIL FLOW	CAPACITY	VOLTAGE	FREQUENCY	POWER	CURRENT	AIR FLOW	PROTECTION	NOISE LEVEL	WEIGHT	ø FAN
l/min	l	V	hz	W	A	m ³ /h	IP	dB(A)	kg	mm
100-300	28	230/400	50	2x 598	2x 2,19	2x 6.300	55	75	120	500
100-300	28	266/460	60	2x 941	2x 2,63	2x 8.800	55	77	120	500

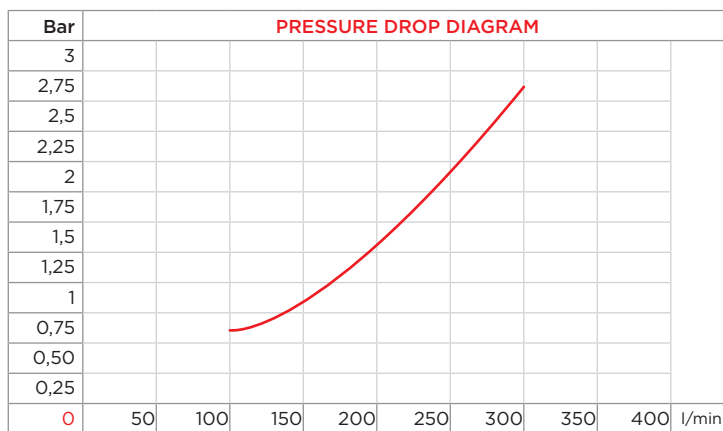
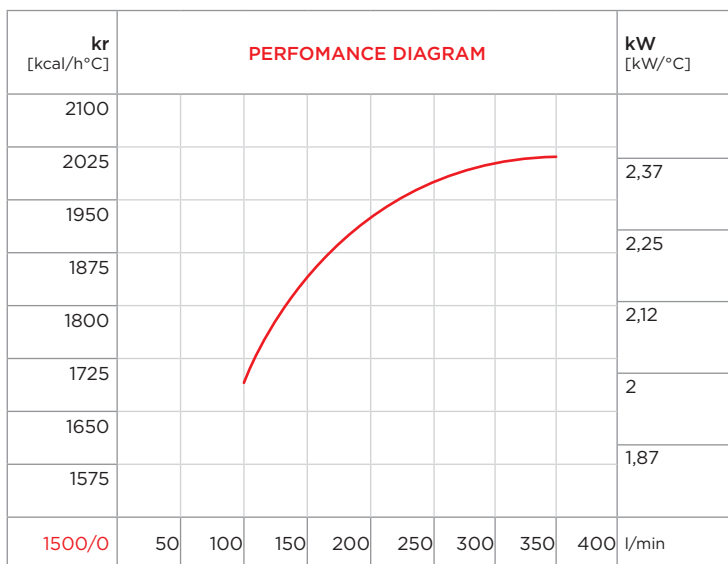

CORRECTION FACTOR

cSt	22	30	46	68	100	150	220
f	0,6	1	1,5	2,3	3,5	5	7

PURCHASE CODES

AP 2/680 EB three-phase	3RAP2/680EB
-------------------------	--------------------

SPARE PARTS

Thermo-switch	1TRM0-90
Shock isolating mounting (4 pcs)	3KIT4232
Electric junction box for	1CSSDSAREL
Cooling element	1RO01339
Electric fan	1VNAP680DV
Frame	3CNAP2/680EB.1

AP 2/730 EB

AC MOTOR AIR-OIL HEAT EXCHANGERS
SCAMBIATORI ARIA-OLIO CON VENTILATORE A CORRENTE ALTERNATA



- Dimensions and technical characteristics are not binding

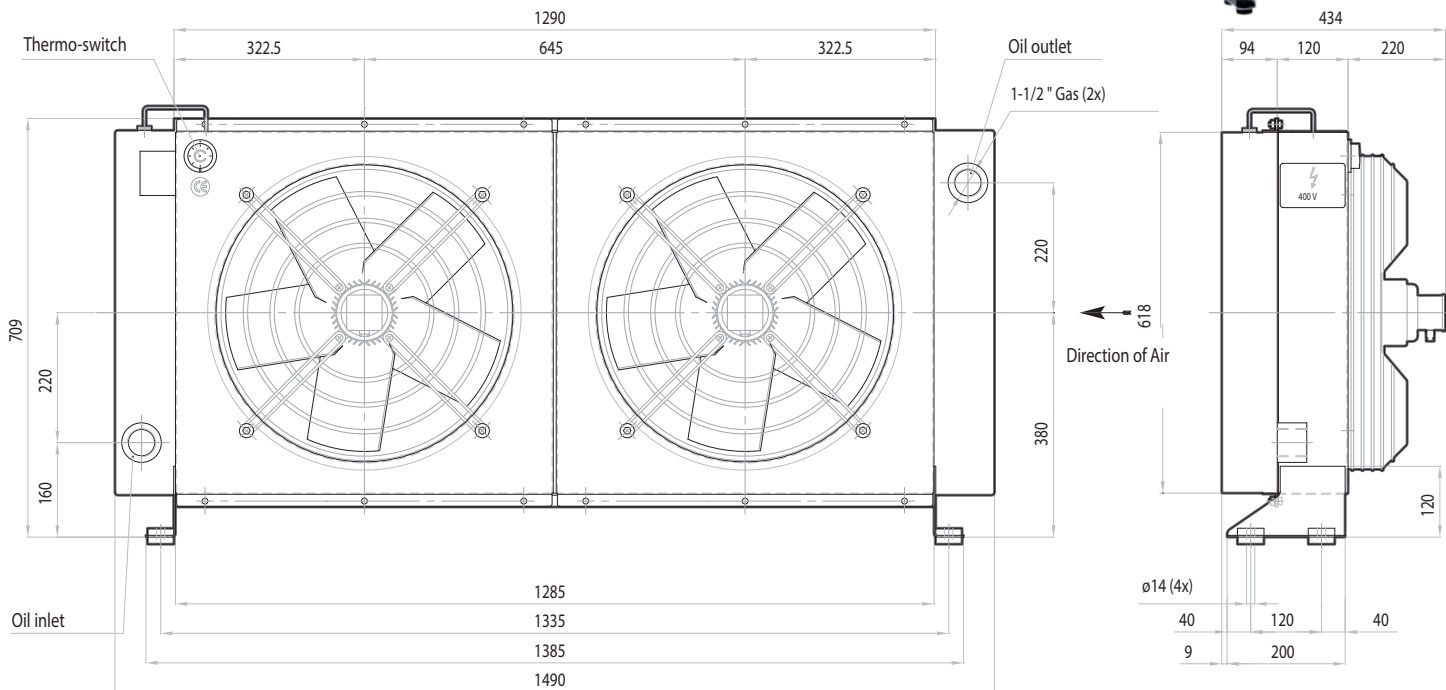

Static working pressure = 20 bar

Test pressure = 35 bar

OIL FLOW	CAPACITY	VOLTAGE	FREQUENCY	POWER	CURRENT	AIR FLOW	PROTECTION	NOISE LEVEL	WEIGHT	Ø FAN
l/min	l	V	hz	W	A	m ³ /h	IP	dB(A)	kg	mm
100-350	30	230/400	50	2x 598	2x 2,19	2x 6.300	55	75	140	500
100-350	30	266/460	60	2x 941	2x 2,63	2x 8.800	55	77	140	500

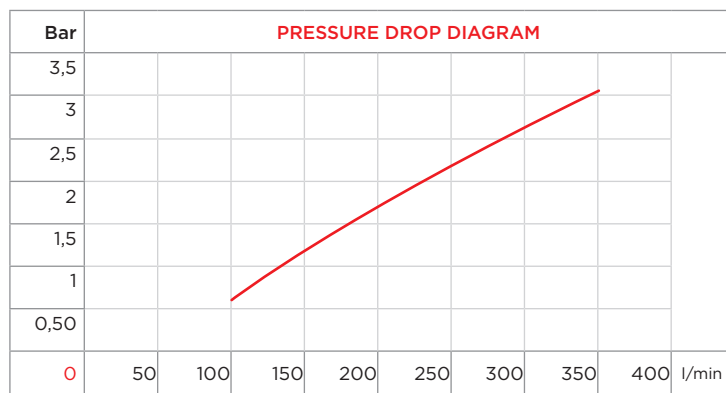
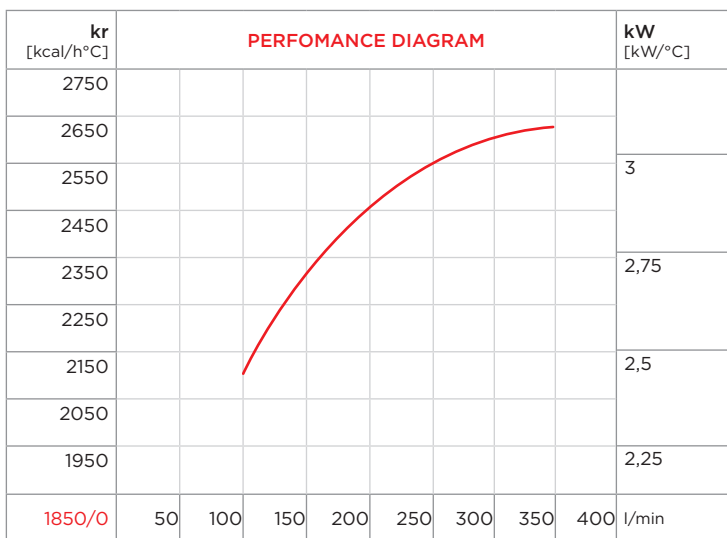

CORRECTION FACTOR

cSt	22	30	46	68	100	150	220
f	0,6	1	1,5	2,3	3,5	5	7

PURCHASE CODES

AP 2/730 EB three-phase	3RAP2/730EB
-------------------------	--------------------

SPARE PARTS

Thermo-switch	1TRM0-90
Shock isolating mounting (4 pcs)	3KIT4232
Electric junction box for	1CSSDSAREL
Cooling element	1RO02357
Electric fan	1VNAP680DV
Frame	3CNAP2/730EB.1

AP 2/830 EB

AC MOTOR AIR-OIL HEAT EXCHANGERS
SCAMBIATORI ARIA-OLIO CON VENTILATORE A CORRENTE ALTERNATA



- Dimensions and technical characteristics are not binding

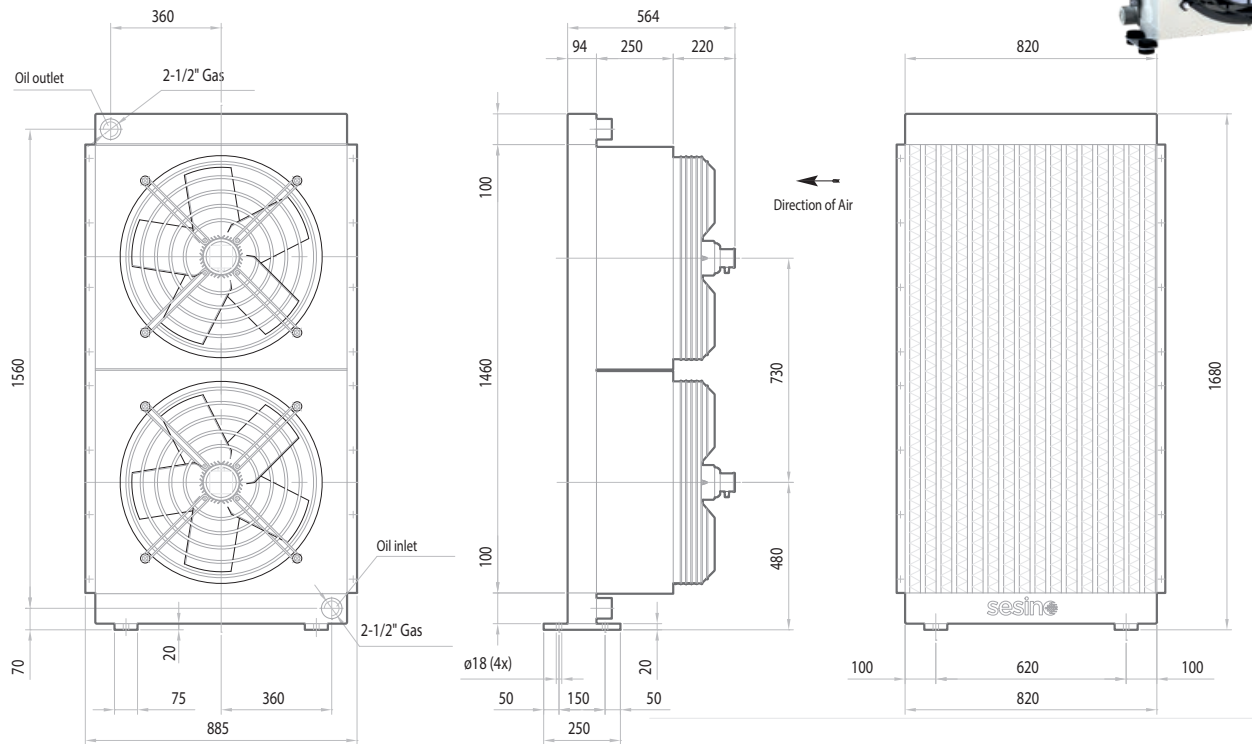

Static working pressure = 20 bar

Test pressure = 35 bar

OIL FLOW	CAPACITY	VOLTAGE	FREQUENCY	POWER	CURRENT	AIR FLOW	PROTECTION	NOISE LEVEL	WEIGHT	Ø FAN
l/min	l	V	hz	W	A	m ³ /h	IP	dB(A)	kg	mm
150-400	40	400	50	2x 719	2x 1,42	2x 9.500	55	73	180	560
upon request only	40	460	60	2x 1132	2x 1,81	2x 11.500	55	75	180	560

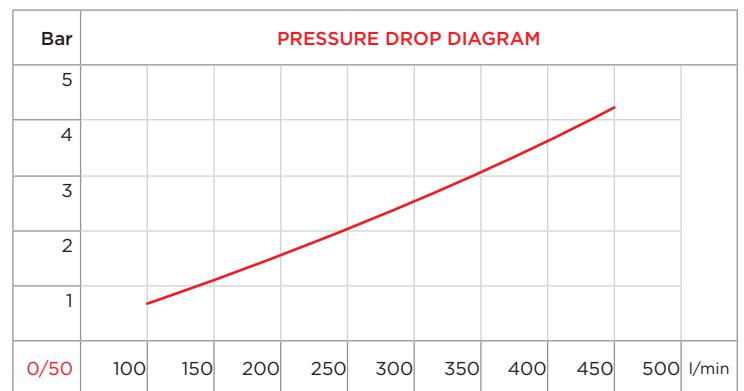
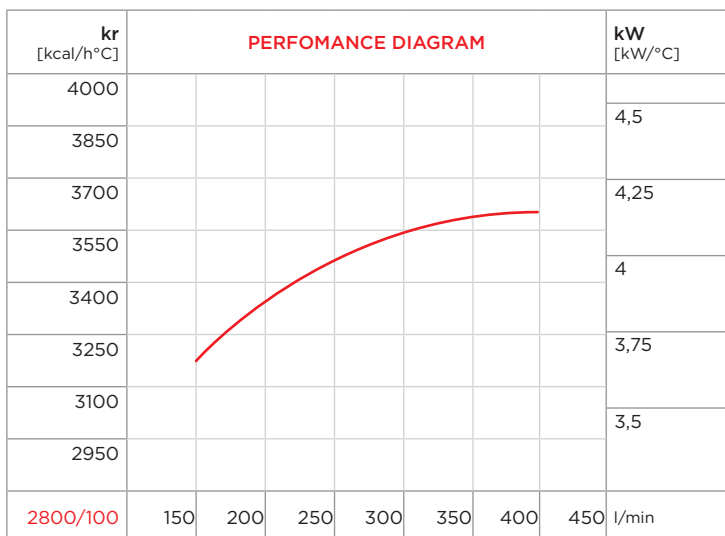

CORRECTION FACTOR

cSt	22	30	46	68	100	150	220
f	0,6	1	1,5	2,3	3,5	5	7

PURCHASE CODES

AP 2/830 EB three-phase	3REO91247
-------------------------	------------------

SPARE PARTS

Frame	3CNE091247.1
Cooling element	3RNE091247
Electric fan for 3REO91247	1VNAP830DV



- Dimensions and technical characteristics are not binding

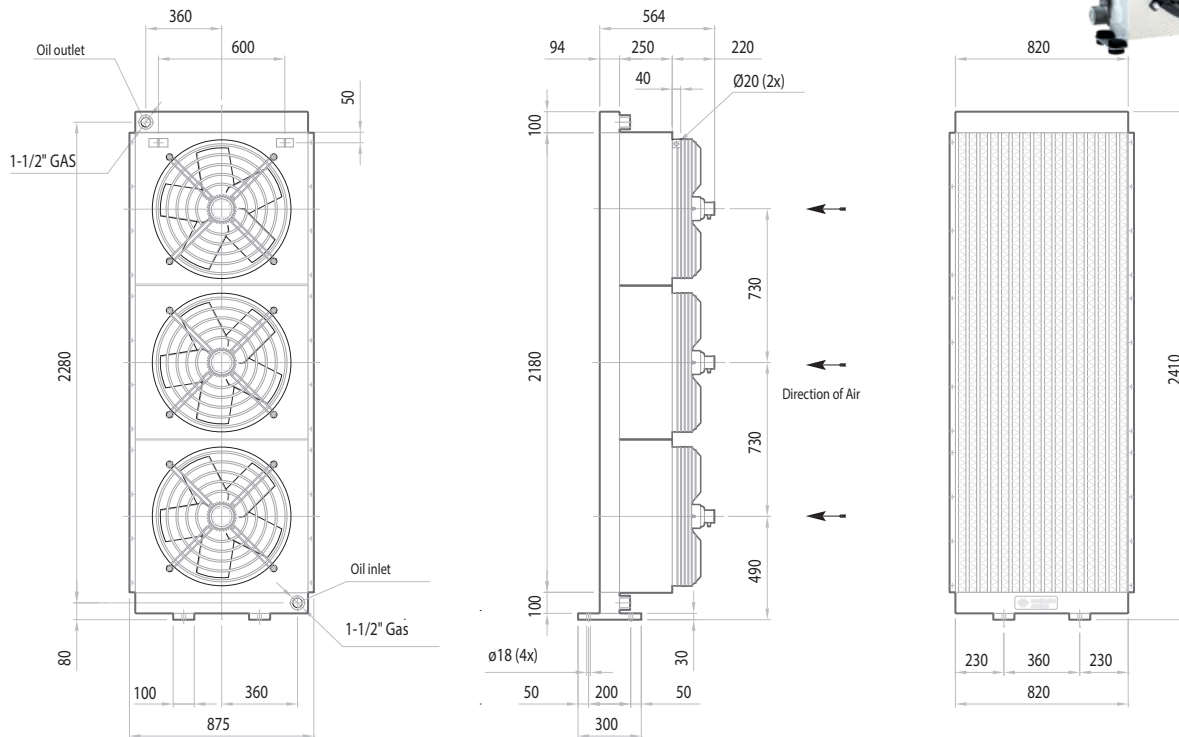

Static working pressure = 20 bar

Test pressure = 35 bar

OIL FLOW	CAPACITY	VOLTAGE	FREQUENCY	POWER	CURRENT	AIR FLOW	PROTECTION	NOISE LEVEL	WEIGHT	Ø FAN
l/min	l	V	hz	W	A	m ³ /h	IP	dB(A)	kg	mm
150-400	600	400	50	2x 719	2x 1,42	3x 9.500	55	78	260	560
upon request only	600	460	60	2x 1132	2x 1,81	3x 11.500	55	78	260	560

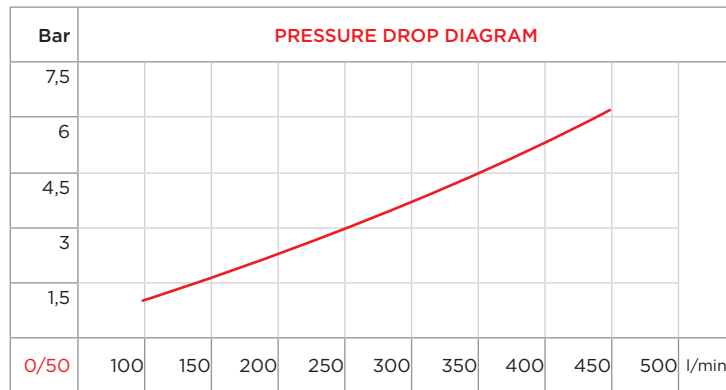
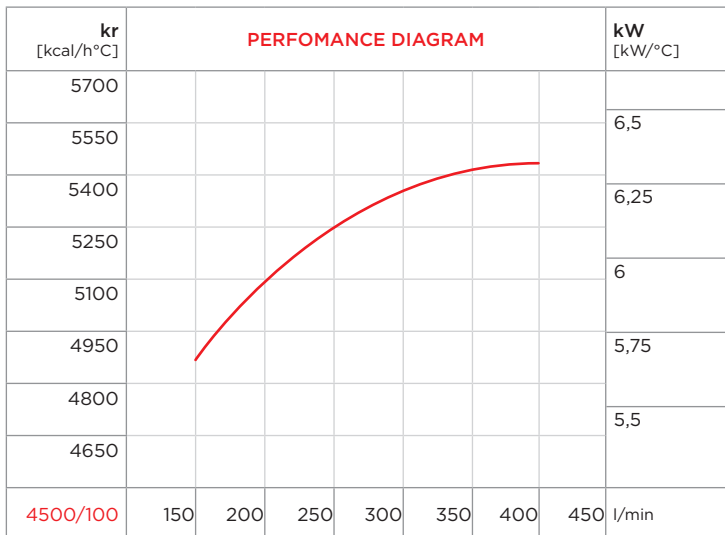

CORRECTION FACTOR

cSt	22	30	46	68	100	150	220
f	0,6	1	1,5	2,3	3,5	5	7

PURCHASE CODES

AP 3/830 EB three-phase	3RE091278
-------------------------	------------------

SPARE PARTS

Frame	3CNE091247.1 3CNE091278.1
Cooling element	3RNE091278
Electric fan	1VNAP830DV

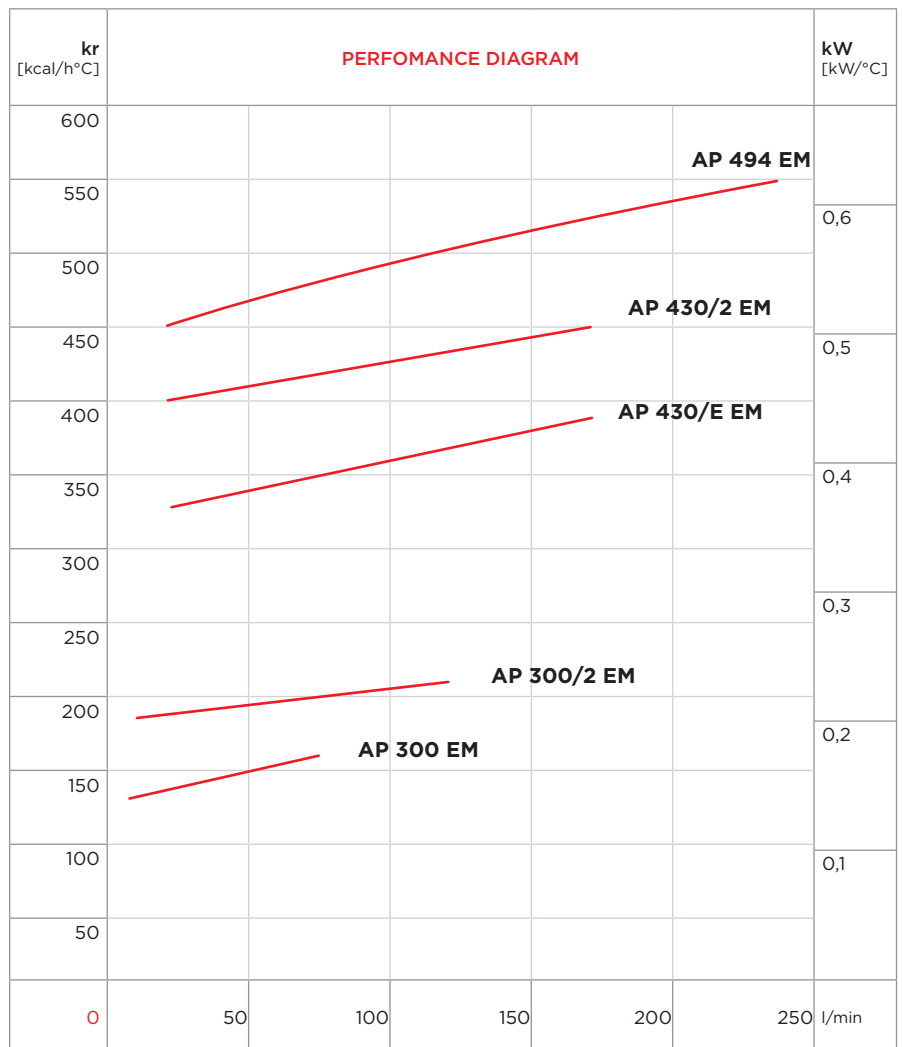
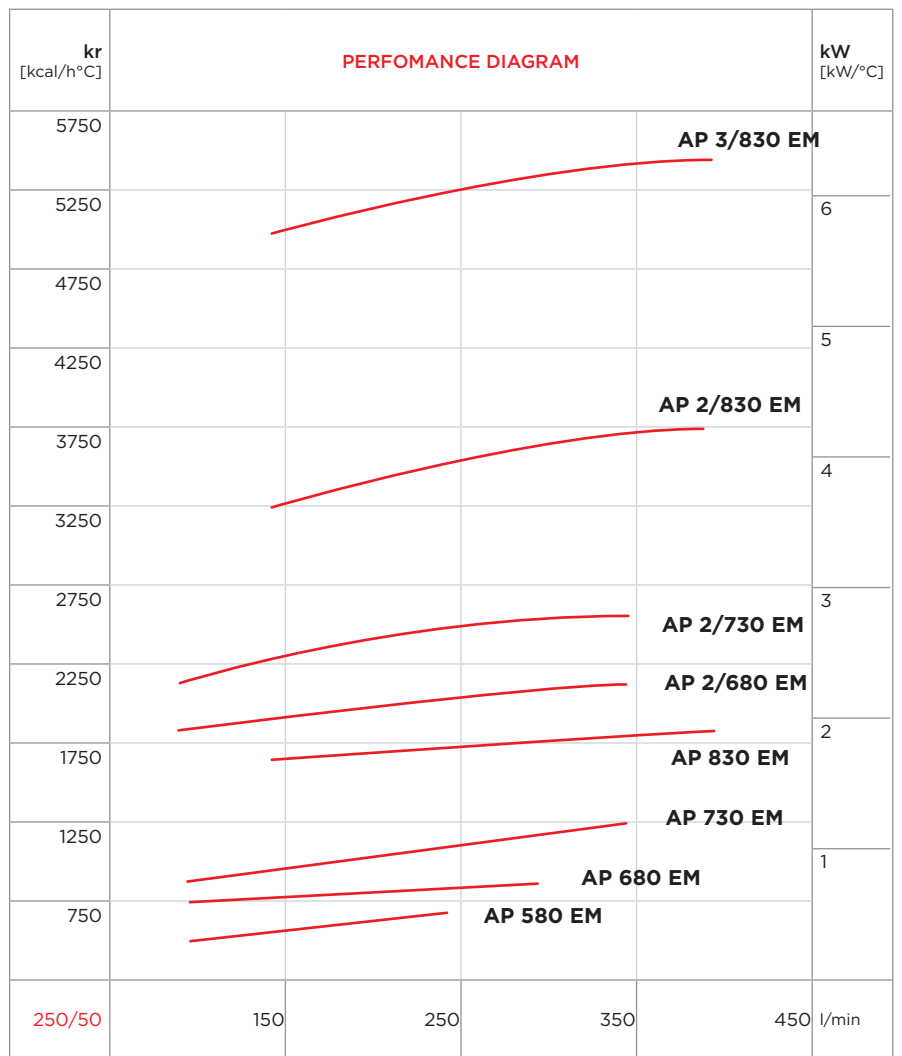

AC MOTOR AIR-OIL HEAT EXCHANGERS MARINE USE EM TYPE

SCAMBIATORI DI CALORE ARIA-OLIO CON VENTILATORE AC USO MARINO SERIE EM



The advantage of using air into the cooling of oleo hydraulic systems has its bases on the following facts:

- There is no need of water
- The system is independent of the connection to the water main
- Lower working costs in comparison with the water-oil exchangers, even if the starting investment is higher
- Possibility to use warm air to heat the room in winter.
- The particular structure of the cooling element allows great thermic performances and pressure resistance.

Maximum working static pressure: 20 bar; test pressure: 35 bar.

It is always recommended to assemble in parallel with the exchanger a by-pass valve to avoid extreme counter-pressures, particularly when the machine is started with cold oil. On the contrary, it is not useful to use a check valve as by-pass to protect the exchanger from pressure's peaks, since the inertia of the valve itself is too high in comparison with the speed of the pressure waves that occur into the oleo hydraulic systems.

The flow rates shown in the tables are the ones recommended for the exchanger proper working.

The efficiency curves show the specific exchange capacity in kcal/h°C or in kW/°C according to the different oil rates. To calculate the heat quantity the different exchangers are able to dissipate it is enough to multiply such capacity by the difference between the requested oil temperature and the summer room temperature.

The heat exchangers type EM have been designed to be used outdoors, in areas where the level of salinity in the air is high (off-shore application).

The components are the following:

- Aluminum cooling element with anodizing and corrosion proofing treatment (SWAAT test according to ASTM G 85-94 ANNEX A3)
- Coated AISI 304 STAINLESS STEEL AISI 304 frame
- Three-phase electric fan, 400V 50Hz or 480V 60Hz, with IP 56 protection degree and STAINLESS STEEL AISI 304 protection grill for off-shore application
- Fixed thermo-switch (47-36°C or 60-49°C) IP 65 protection degree

For the right calculation of air-oil heat exchangers, we supply our customers with a calculation software.

The air-oil heat exchangers can be used to cool other kind of fluids, which must be compatible with aluminum and its alloys.

However, for each use, with the exception of oil cooling, we recommend to consult our Technical Department.

Il vantaggio dell'utilizzo dell'aria nel raffreddamento di impianti oleoidraulici trova le sue ragioni nei seguenti fattori:

- Non necessità l'utilizzo di acqua
- Indipendenza della macchina dalle tubazioni di allacciamento alla rete idrica
- Inferiore costo di esercizio rispetto agli scambiatori acqua-olio, anche se maggiore è l'investimento iniziale
- Possibilità di utilizzare l'aria calda in uscita per riscaldare l'ambiente nella stagione invernale
- La particolare costruzione del radiatore consente di ottenere notevoli rese termiche e forte resistenza alla pressione.

Pressione massima statica di funzionamento: 20 bar; pressione di collaudo: 35 bar.

È sempre consigliabile montare in parallelo allo scambiatore una valvola di by-pass per evitare eccessive contropressioni soprattutto al momento dell'avviamento della macchina con olio freddo. Non è invece conveniente utilizzare una valvola di ritegno come by-pass per proteggere lo scambiatore dai picchi di pressione in quanto l'inerzia della valvola stessa è troppo alta rispetto alla velocità delle onde di pressione che si sviluppano all'interno dell'olio degli impianti oleoidraulici. Le portate olio indicate nelle tabelle sono quelle consigliate per il buon funzionamento dello scambiatore.

Le curve di rendimento forniscono la potenzialità di scambio specifica in kcal/h°C o in kW/h°C in funzione della portata olio; per calcolare la quantità di calore che i vari scambiatori sono in grado di disperdere, è sufficiente moltiplicare tale potenzialità per la differenza tra le temperature dell'olio desiderata e dell'aria ambiente massima estiva.

Gli scambiatori della serie EM sono stati concepiti per essere installati all'aperto in zone dove la concentrazione di salinità dell'aria è elevata (applicazioni off-shore).

I componenti sono i seguenti:

- Radiatore in alluminio con trattamento di anodizzazione anticorrosione (SWAAT test secondo norme ASTM G 85-94 ANNEX A3)
- Telaio in acciaio inossidabile AISI 304 verniciato
- Elettroventola trifase 400V 50Hz o 480V 60Hz con protezione IP 56 e rete in acciaio inossidabile adatta ad applicazioni off-shore
- Termostato taratura fissa (47-36°C o 60-49°C) protezione IP 65

Per il calcolo degli scambiatori aria-olio è disponibile un software.

Gli scambiatori aria-olio possono essere utilizzati per raffreddare altri tipi di fluidi, a condizione che essi siano compatibili con l'alluminio e le sue leghe.

Consigliamo comunque, per qualsiasi impiego che non sia il raffreddamento dell'olio, di contattare il nostro Ufficio Tecnico.

AP 300 EM

AIR-OIL HEAT EXCHANGERS MARINE USE EM TYPE
SCAMBIATORI ARIA-OLIO CON VENTILATORE AC USO MARINO SERIE EM



- Dimensions and technical characteristics are not binding

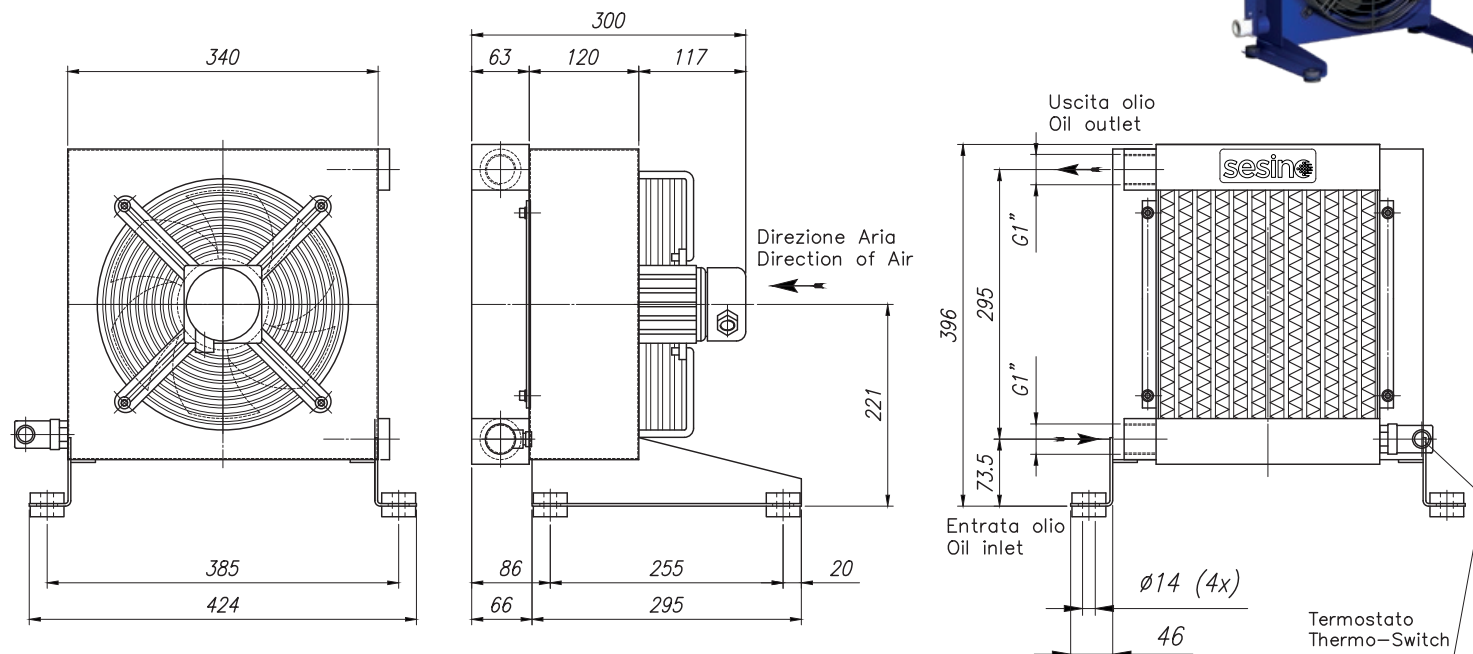

Static working pressure = 20 bar

Test pressure = 35 bar

CODE	OIL FLOW l/min	CAP. l	VOLT. V	FREQ. Hz	POWER W	CURRENT A	AIR FLOW m ³ /h	PROT. IP	NOISE LEV. dB(A)	W kg	φ FAN mm	TEMP. °C
3RAP300EM50ST	10-80	2	220-240(Δ) / 380-415 (Y)	50	180	0,4	1500	56	73	12	250	-20/+40
3RAP300EM60ST	10-80	2	460 (Y)	60	285	0,6	1580	56	73	12	250	-20/+40

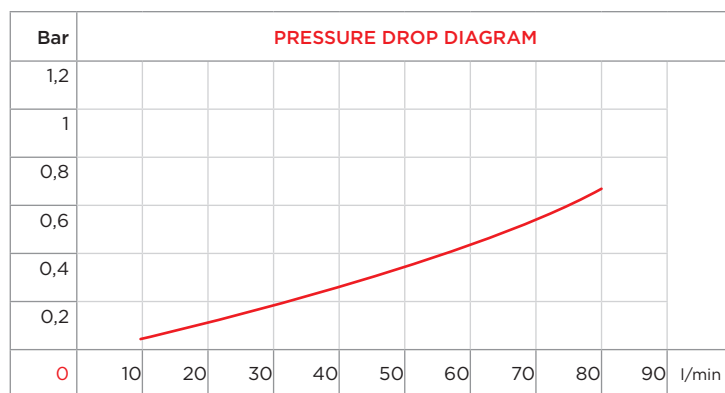
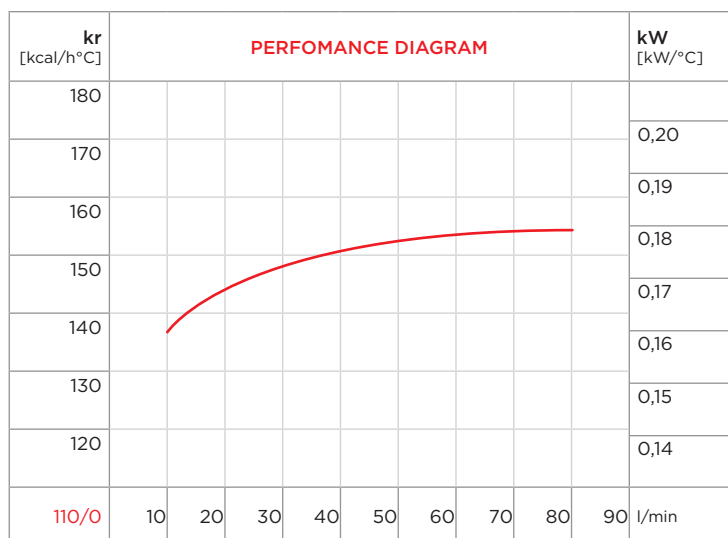

CORRECTION FACTOR							
cSt	22	30	46	68	100	150	220
f	0,6	1	1,5	2,3	3,5	5	7

PURCHASE CODES

AP 300 EM three-phase 380-415V 50Hz with thermo-switch	3RAP300EM50T247 3RA-P300EM50T260
AP 300 EM three-phase 460V 60 Hz with thermo-switch	3RAP300EM60T247 3RA-P300EM60T260
AP 300 EM three-phase 380-415V 50Hz without thermo-switch	3RAP300EM50ST
AP 300 EM three-phase 460V 60 Hz without thermo-switch	3RAP300EM60ST

SPARE PARTS

Cooling element	3RNL300A
Frame	3CNAP300EM.1
Electric fan 380-415V 50Hz	1VNAP300EM50
Electric fan 460V 60 Hz	1VNAP300EM60
Thermo-switch 47-36	1TRM 47-36
Thermo-switch 60-49	1TRM 60-49

AP 300/2 EM

AIR-OIL HEAT EXCHANGERS MARINE USE EM TYPE
SCAMBIATORI ARIA-OLIO CON VENTILATORE AC USO MARINO SERIE EM



- Dimensions and technical characteristics are not binding

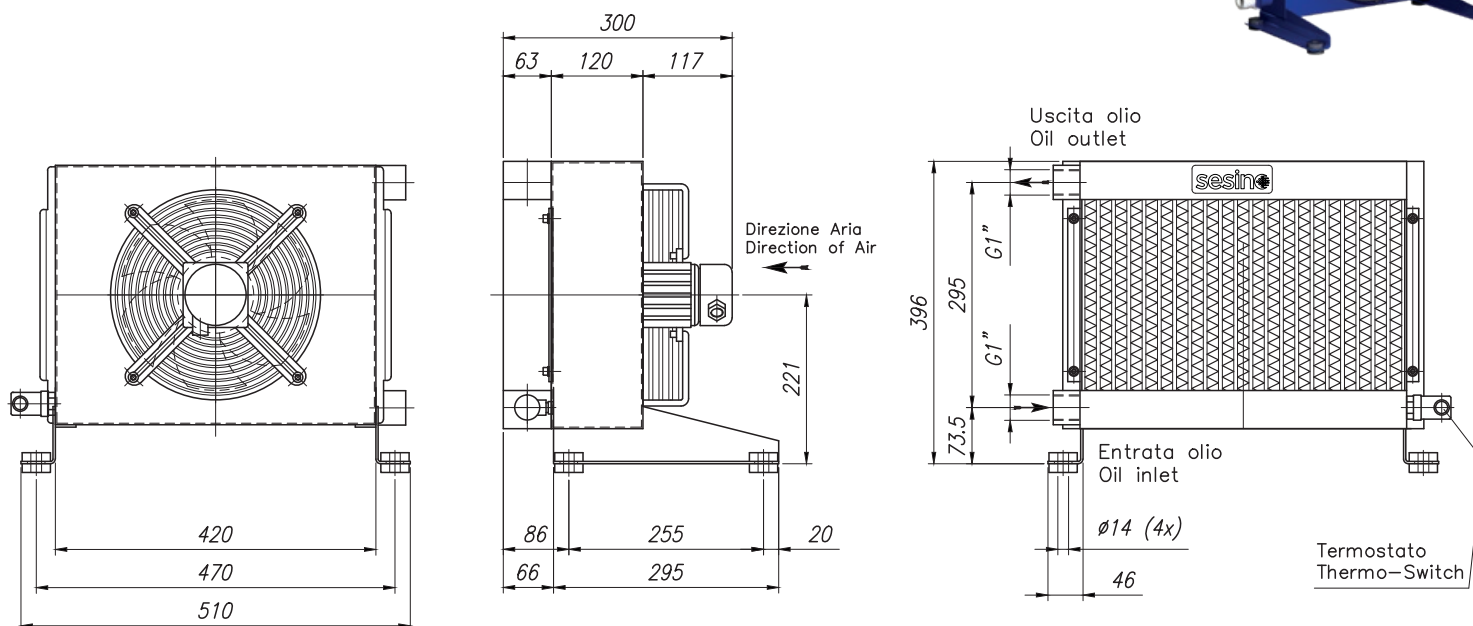

Static working pressure = 20 bar

Test pressure = 35 bar

CODE	OIL FLOW l/min	CAP. l	VOLT. V	FREQ. Hz	POWER W	CURRENT A	AIR FLOW m ³ /h	PROT. IP	NOISE LEV. dB(A)	W kg	ø FAN mm	TEMP. °C
3RAP302EM50ST	20-160	3,6	220-240(Δ) / 380-415	50	180	0,4	1700	56	73	17	250	-20/+40
3RAP302EM60ST	20-160	3,6	460 (Y)	60	285	0,6	1800	56	73	17	250	-20/+40

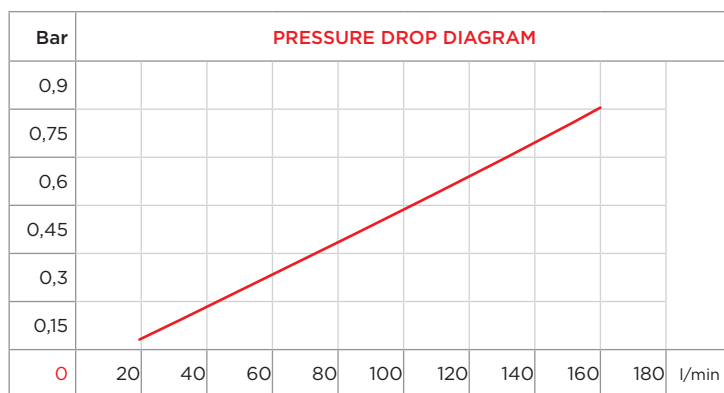
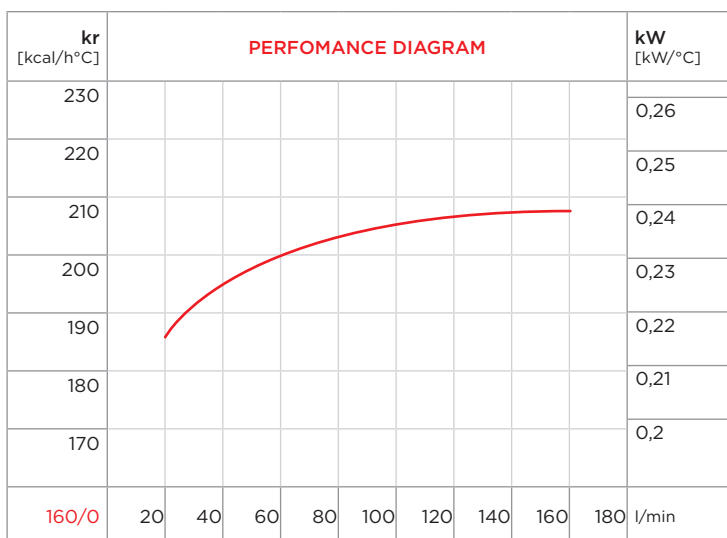

CORRECTION FACTOR

	22	30	46	68	100	150	220
cSt	0,6	1	1,5	2,3	3,5	5	7

PURCHASE CODES

AP 300 EM three-phase 380-415V 50Hz with thermo-switch	3RAP302EM50T247 3RAP302EM50T260
AP 300 EM three-phase 460V 60 Hz with thermo-switch	3RAP302EM60T247 3RAP302EM60T260
AP 300 EM three-phase 380-415V 50Hz without thermo-switch	3RAP302EM50ST
AP 300 EM three-phase 460V 60 Hz without thermo-switch	3RAP302EM60ST

SPARE PARTS

Cooling element	3RNL302A
Frame	3CNAP302EM.1
Electric fan 380-415V 50Hz	1VNAP300EM50
Electric fan 460V 60 Hz	1VNAP300EM60
Thermo-switch 47-36	1TRM 47-36
Thermo-switch 60-49	1TRM 60-49

AP 430 EM

AIR-OIL HEAT EXCHANGERS MARINE USE EM TYPE
SCAMBIATORI ARIA-OLIO CON VENTILATORE AC USO MARINO SERIE EM



- Dimensions and technical characteristics are not binding

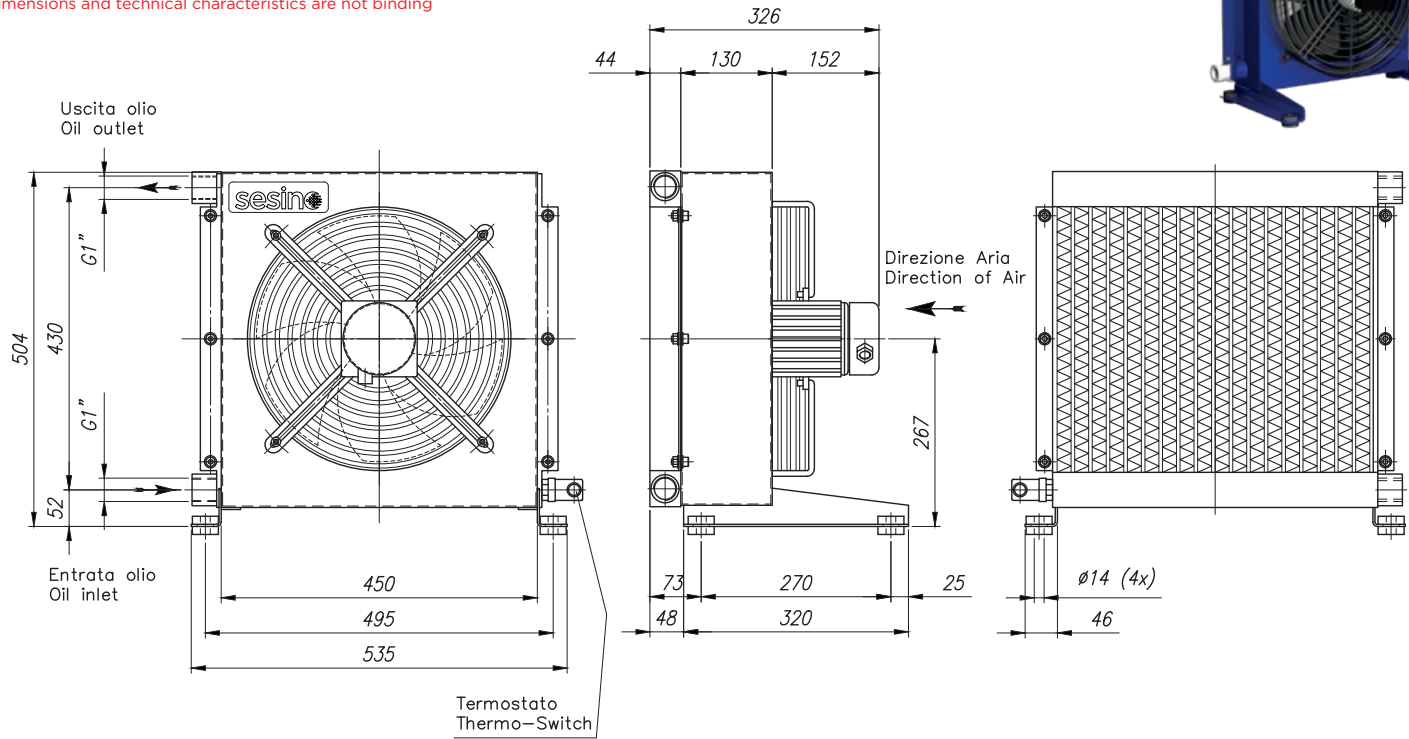

Static working pressure = 20 bar

Test pressure = 35 bar

CODE	OIL FLOW l/min	CAPACITY l	VOLT. V	FREQ. Hz	POWER W	CURRENT A	AIR FLOW m ³ /h	PROT. IP	NOISE LEV. dB(A)	W kg	ø FAN mm	TEMP. °C
3RAP430EM50ST	30-180	3,6	220-240(Δ) / 380-415	50	162	0,64	2600	56	73	20	350	-20/+40
3RAP430EM60ST	30-180	3,6	460 (Y)	60	241	0,62	2800	56	73	20	350	-20/+40

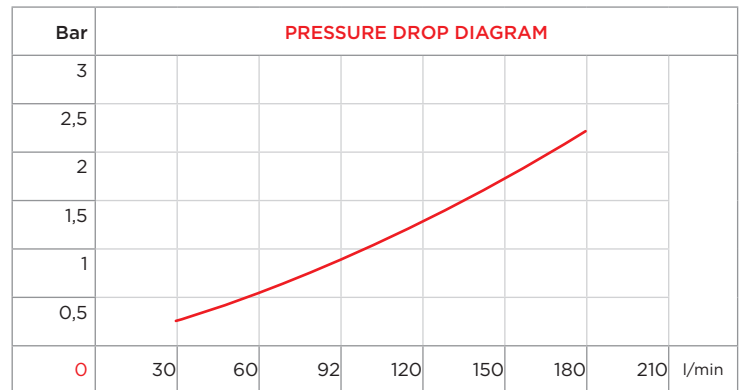
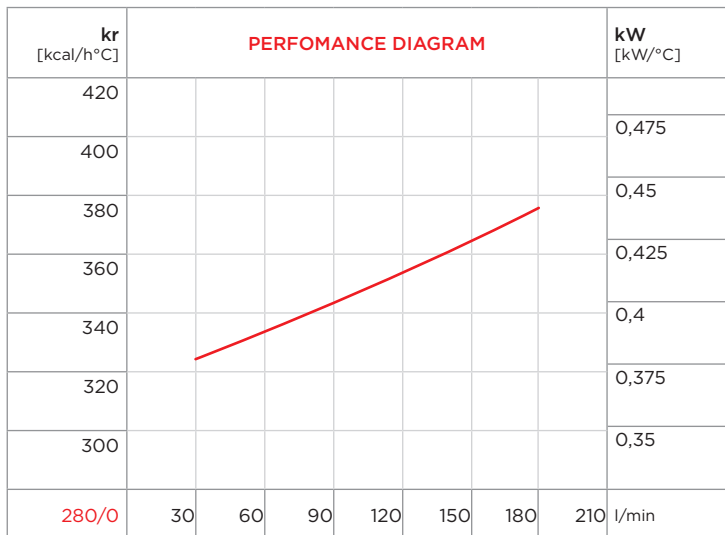

CORRECTION FACTOR

cSt	22	30	46	68	100	150	220
f	0,6	1	1,5	2,3	3,5	5	7

PURCHASE CODES

AP 430 EM three-phase 380-415V 50Hz with thermo-switch	3RAP430EM50T247 3RA-P430EM50T260
AP 430 EM three-phase 460V 60 Hz with thermo-switch	3RAP430EM60T247 3RA-P430EM60T260
AP 430 EM three-phase 380-415V 50Hz without thermo-switch	3RAP430EM50ST
AP 430 EM three-phase 460V 60 Hz without thermo-switch	3RAP430EM60ST

SPARE PARTS

Cooling element	3RNL430A
Frame	3CNAP430EM.1
Electric fan 380-415V 50Hz	1VNAP430EM50
Electric fan 460V 60 Hz	1VNAP430EM60
Thermo-switch 47-36	1TRM 47-36
Thermo-switch 60-49	1TRM 60-49

AP 430/2 EM

AIR-OIL HEAT EXCHANGERS MARINE USE EM TYPE
SCAMBIATORI ARIA-OLIO CON VENTILATORE AC USO MARINO SERIE EM



- Dimensions and technical characteristics are not binding

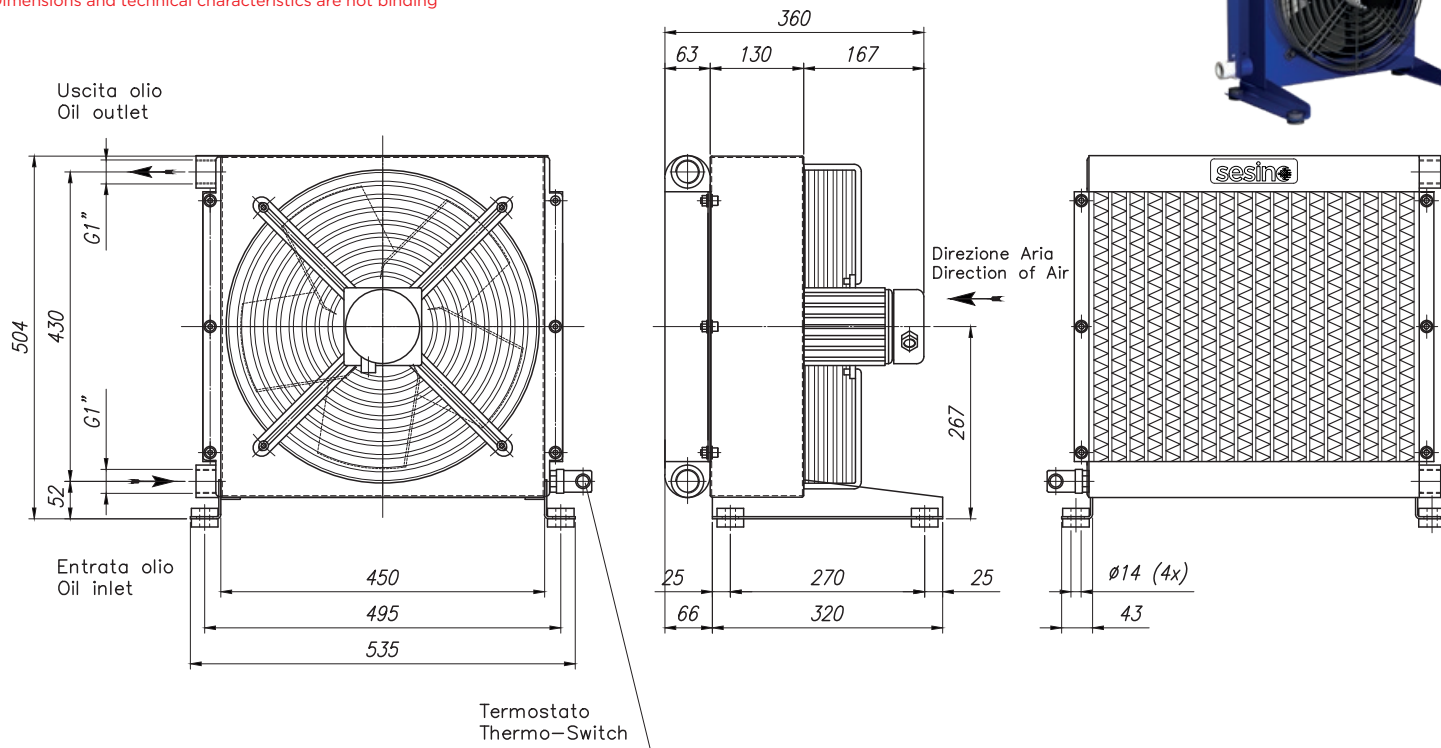

Static working pressure = 20 bar

Test pressure = 35 bar

CODE	OIL FLOW l/min	CAPACITY l	VOLT. V	FREQ. Hz	POWER W	CURRENT A	AIR FLOW m ³ /h	PROT. IP	NOISE LEV. dB(A)	W kg	ø FAN mm	TEMP. °C
3RAP432EM50ST	30-180	5,5	220-240(Δ) / 380-415	50	196	0,72	3500	56	72	28	400	-20/+40
3RAP432EM60ST	30-180	5,5	460 (Y)	60	261	0,72	3700	56	72	28	400	-20/+40

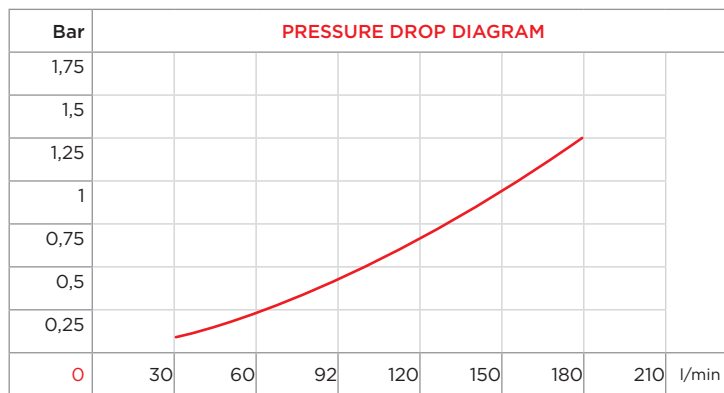
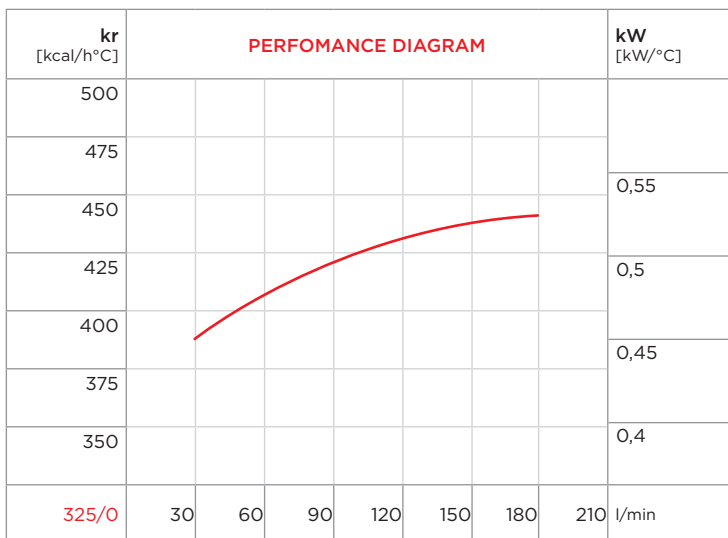

CORRECTION FACTOR

cSt	22	30	46	68	100	150	220
f	0,6	1	1,5	2,3	3,5	5	7

PURCHASE CODES

AP 430/2 EM three-phase 380-415V 50Hz with thermo-switch	3RAP432EM50T247 3RAP432EM50T260
AP 430/2 EM three-phase 460V 60 Hz with thermo-switch	3RAP432EM60T247 3RAP432EM60T260
AP 430/2 EM three-phase 380-415V 50Hz without thermo-switch	3RAP432EM50ST
AP 430/2 EM three-phase 460V 60 Hz without thermo-switch	3RAP432EM60ST

SPARE PARTS

Cooling element	3RNL432A
Frame	3CNAP432EM.1
Electric fan 380-415V 50Hz	1VNAP432EM50
Electric fan 460V 60 Hz	1VNAP432EM60
Thermo-switch 47-36	1TRM 47-36
Thermo-switch 60-49	1TRM 60-49

AP 494 EM

AIR-OIL HEAT EXCHANGERS MARINE USE EM TYPE
SCAMBIATORI ARIA-OLIO CON VENTILATORE AC USO MARINO SERIE EM



- Dimensions and technical characteristics are not binding

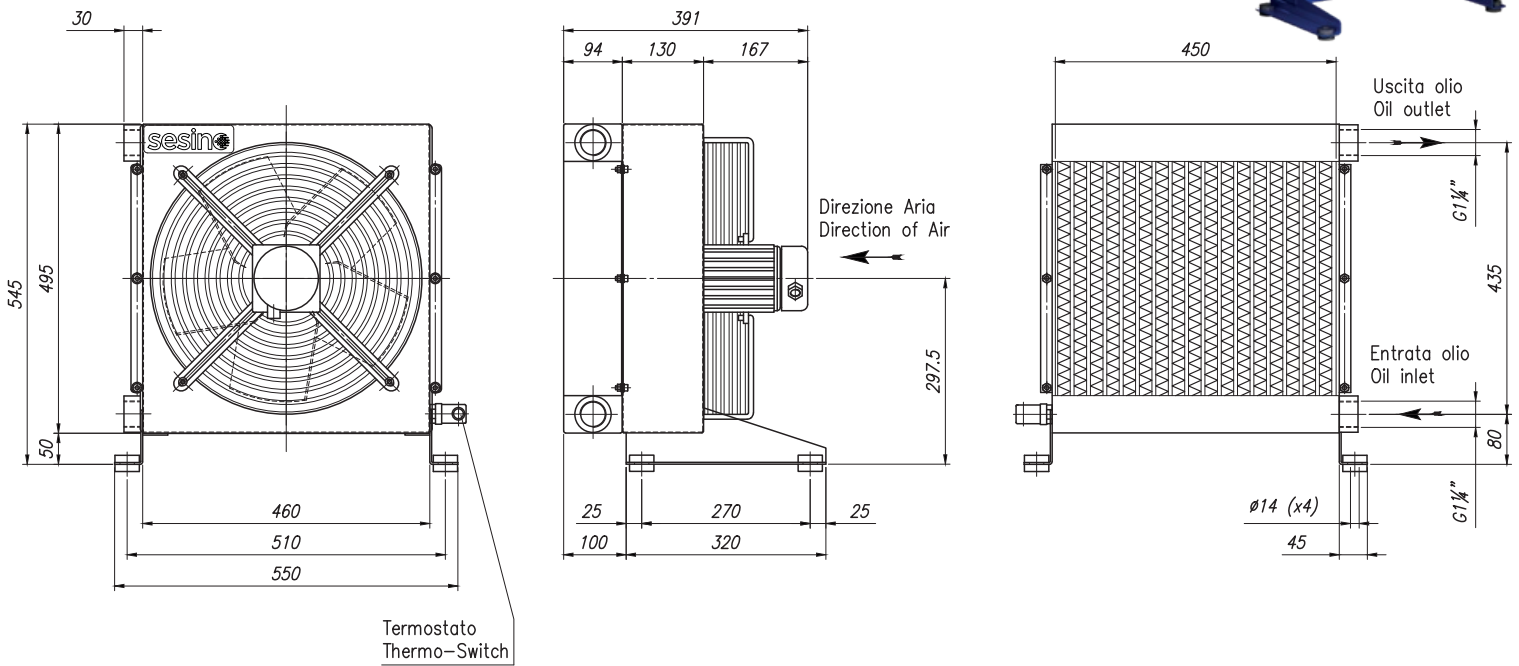

Static working pressure = 20 bar

Test pressure = 35 bar

CODE	OIL FLOW l/min	CAP. l	VOLT. V	FREQ. Hz	POWER W	CURRENT A	AIR FLOW m ³ /h	PROT. IP	NOISE LEV. dB(A)	WEIGHT kg	Ø FAN mm	TEMP. °C
3RAP494EM50ST	30-240	8	220-240(Δ) / 380-415	50	196	0,72	3300	56	73	30	400	-20/+40
3RAP494EM60ST	30-240	8	460 (Y)	60	261	0,72	3500	56	73	30	400	-20/+40

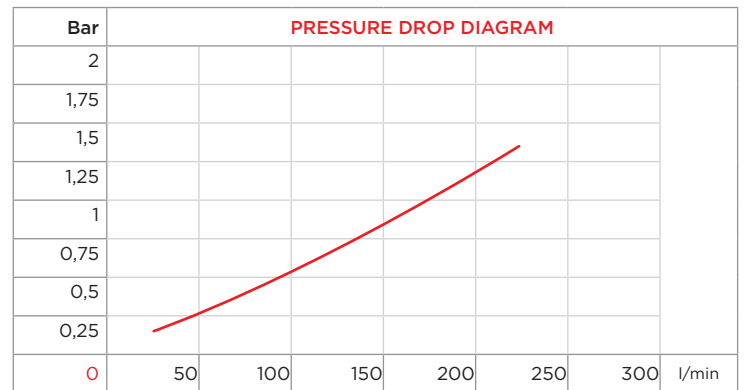
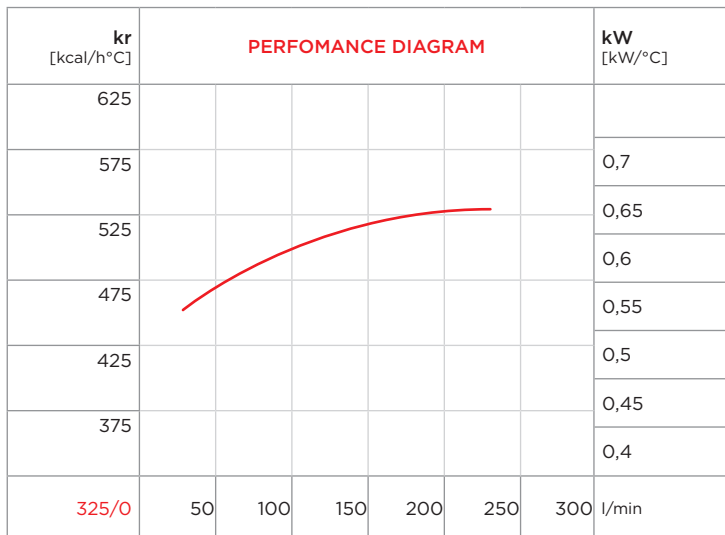

CORRECTION FACTOR							
cSt	22	30	46	68	100	150	220
f	0,6	1	1,5	2,3	3,5	5	7

PURCHASE CODES

AP 494 EM three-phase 380-415V 50Hz with thermo-switch	3RAP494EM50T247 3RAP494EM50T260
AP 494 EM three-phase 460V 60 Hz with thermo-switch	3RAP494EM60T247 3RAP494EM60T260
AP 494 EM three-phase 380-415V 50Hz without thermo-switch	3RAP494EM50ST
AP 494 EM three-phase 460V 60 Hz without thermo-switch	3RAP494EM60ST

SPARE PARTS

Cooling element	3RNL494A
Frame	3CNAP494EM.1
Electric fan 380-415V 50Hz	1VNAP432EM50
Electric fan 460V 60 Hz	1VNAP432EM60
Thermo-switch 47-36	1TRM 47-36
Thermo-switch 60-49	1TRM 60-49

AP 580 EM

AIR-OIL HEAT EXCHANGERS MARINE USE EM TYPE
SCAMBIATORI ARIA-OLIO CON VENTILATORE AC USO MARINO SERIE EM



- Dimensions and technical characteristics are not binding

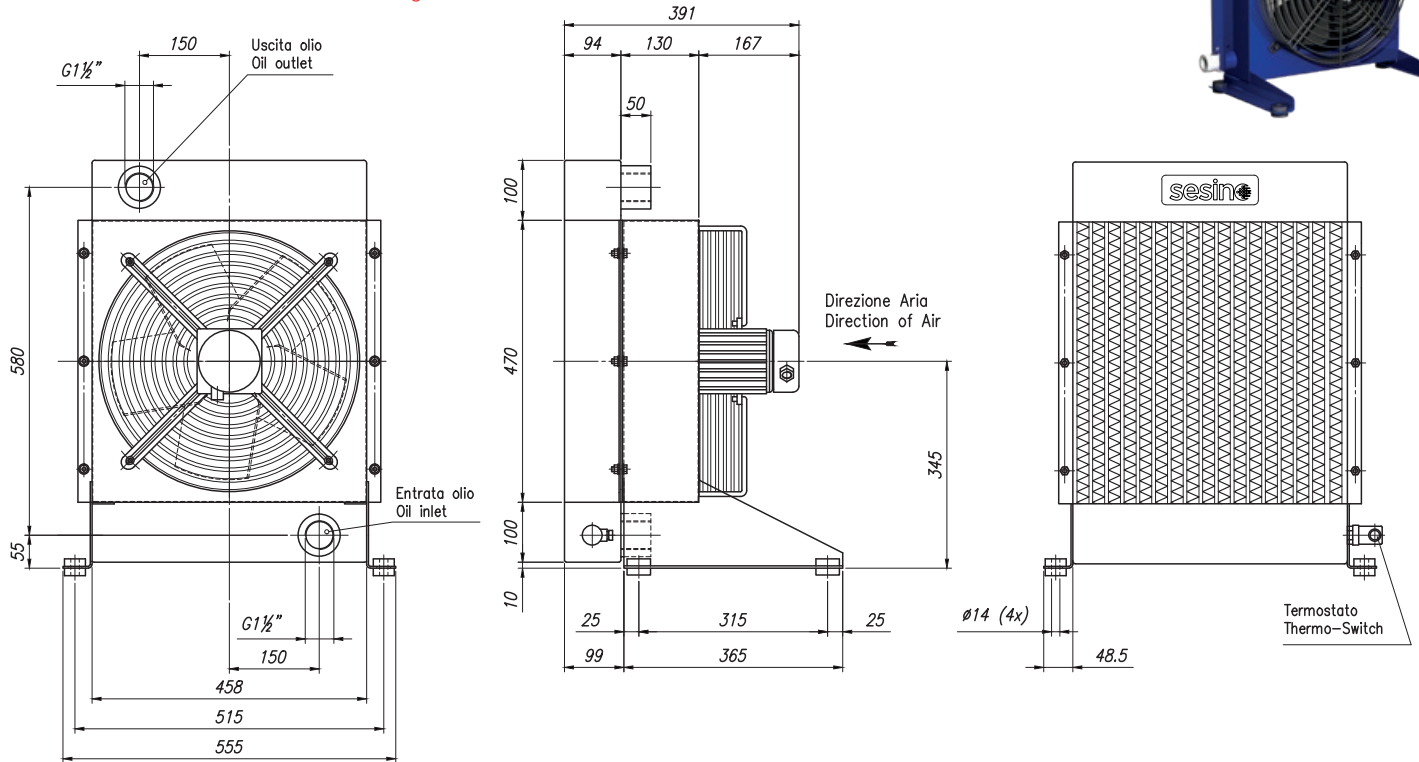

Static working pressure = 20 bar

Test pressure = 35 bar

CODE	OIL FLOW l/min	CAP. l	VOLT. V	FREQ. Hz	POWER W	CURRENT A	AIR FLOW m ³ /h	PROT. IP	NOISE LEV. dB(A)	WEIGHT kg	Ø FAN mm	TEMP. °C
3RAP580EM50ST	100-250	11,5	220-240(Δ) / 380-415	50	196	0,72	3500	56	72	45	400	-20/+40
3RAP580EM60ST	100-250	11,5	460 (Y)	60	261	0,72	3700	56	72	45	400	-20/+40

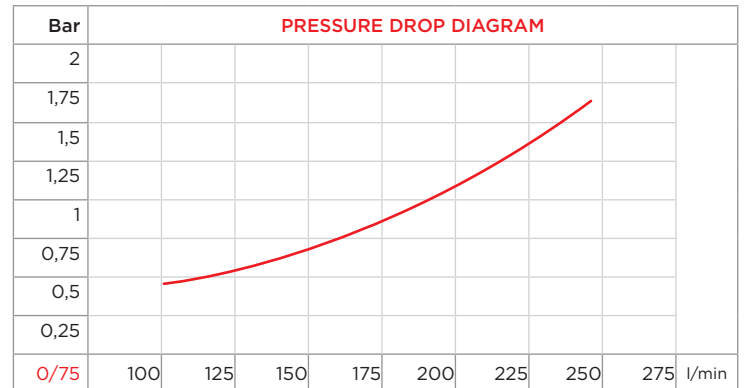
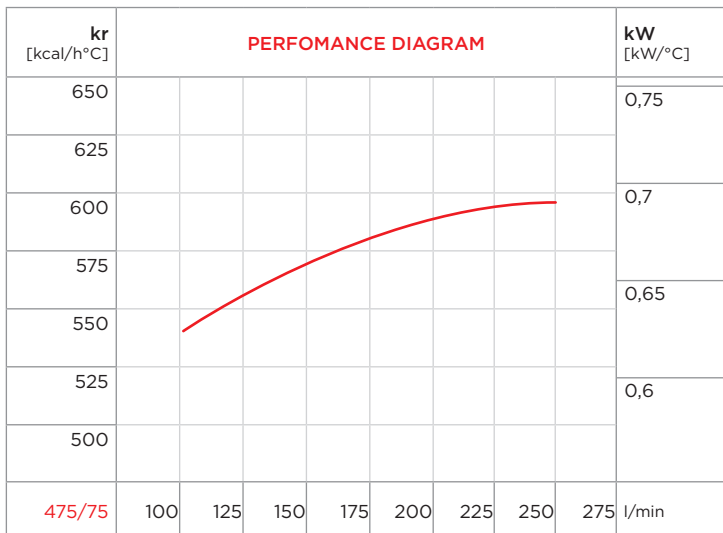

CORRECTION FACTOR

cSt	22	30	46	68	100	150	220
f	0,6	1	1,5	2,3	3,5	5	7

PURCHASE CODES

AP 580 EM three-phase 380-415V 50Hz with thermo-switch	3RAP580EM50T247 3RAP580EM50T260
AP 580 EM three-phase 460V 60 Hz with thermo-switch	3RAP580EM60T247 3RAP580EM60T260
AP 580 EM three-phase 380-415V 50Hz without thermo-switch	3RAP580EM50ST
AP 580 EM three-phase 460V 60 Hz without thermo-switch	3RAP580EM60ST

SPARE PARTS

Cooling element	3RNL580A
Frame	3CNAP580EM.1
Electric fan 380-415V 50Hz	1VNAP432EM50
Electric fan 460V 60 Hz	1VNAP432 EM60
Thermo-switch 47-36	1TRM 47-36
Thermo-switch 60-49	1TRM 60-49

AP 680 EM

AIR-OIL HEAT EXCHANGERS MARINE USE EM TYPE
SCAMBIATORI ARIA-OLIO CON VENTILATORE AC USO MARINO SERIE EM



- Dimensions and technical characteristics are not binding

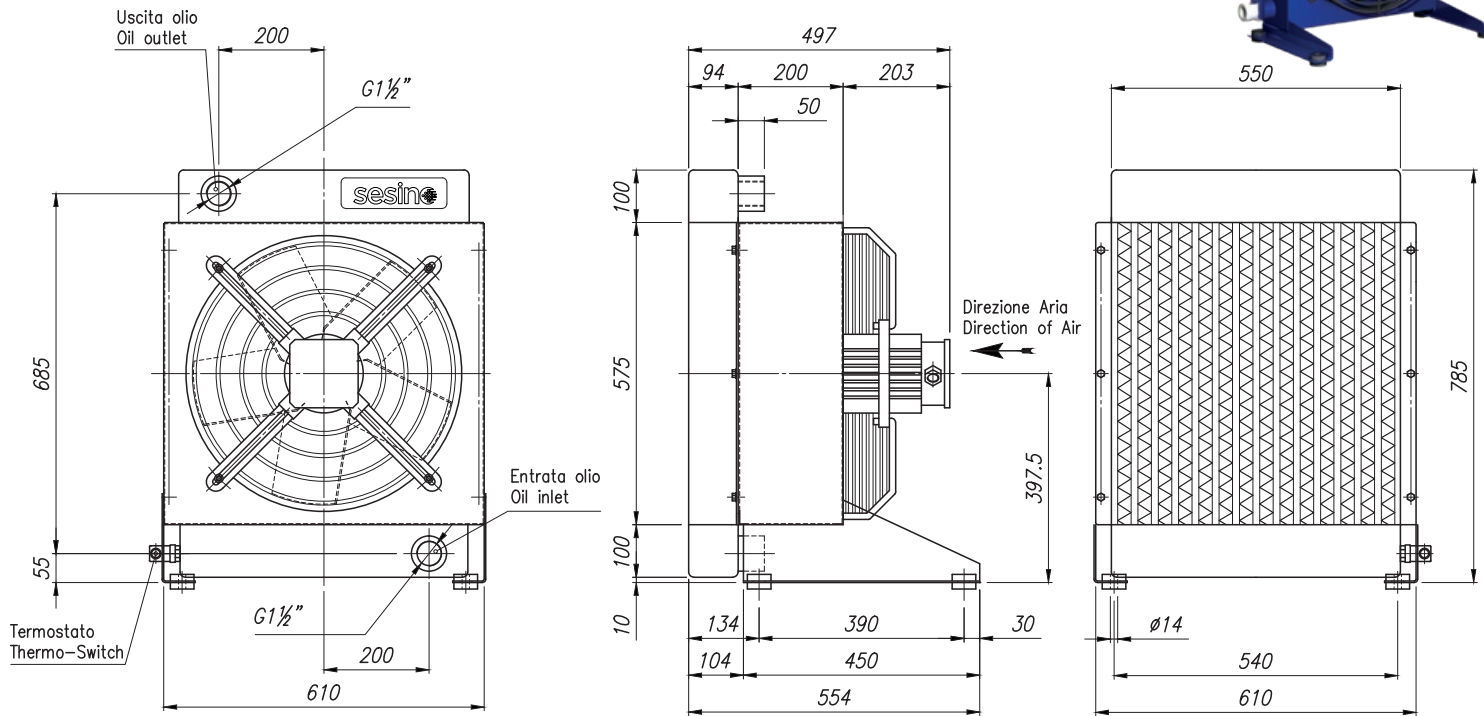

Static working pressure = 20 bar

Test pressure = 35 bar

CODE	OIL FLOW l/min	CAP. l	VOLT. V	FREQ. Hz	POWER W	CURRENT A	AIR FLOW m ³ /h	PROT. IP	NOISE LEV. dB(A)	WEIGHT kg	ø FAN mm	TEMP. °C
3RAP680EM50ST	100-300	15	220-240(Δ) / 380-415	50	725	1,34	7500	56	75	67	500	-20/+40
3RAP680EM60ST	100-300	15	460 (Y)	60	816	1,27	7900	56	75	67	500	-20/+40

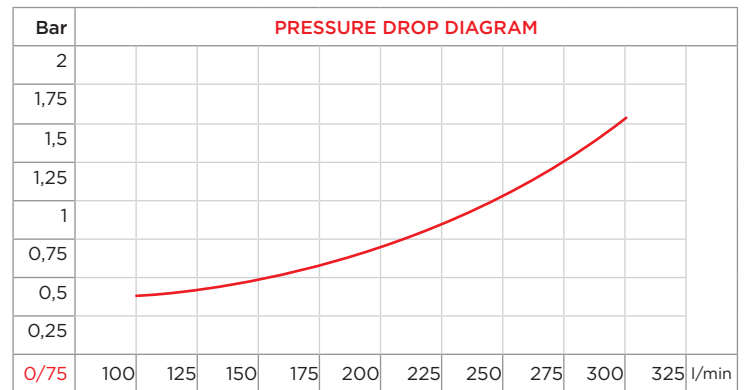
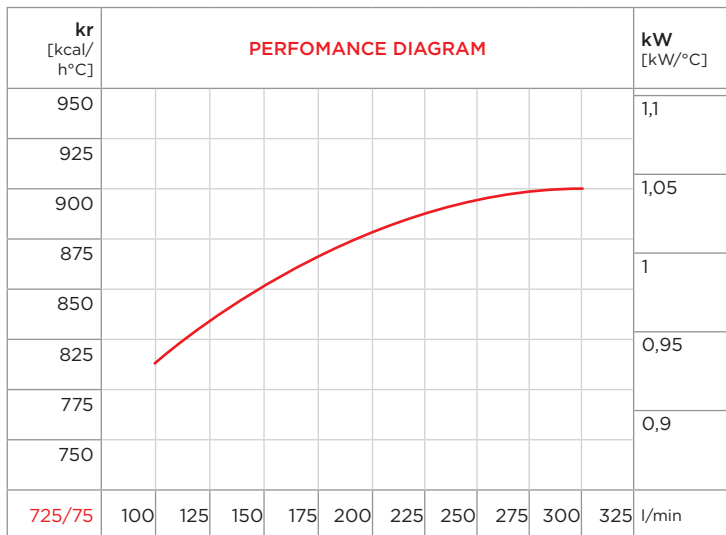

CORRECTION FACTOR							
cSt	22	30	46	68	100	150	220
f	0,6	1	1,5	2,3	3,5	5	7

PURCHASE CODES

AP 680 EM three-phase 380-415V 50Hz with thermo-switch	3RAP680EM50T247 3RAP680EM50T260
AP 680 EM three-phase 460V 60 Hz with thermo-switch	3RAP680EM60T247 3RAP680EM60T260
AP 680 EM three-phase 380-415V 50Hz without thermo-switch	3RAP680EM50ST
AP 680 EM three-phase 460V 60 Hz without thermo-switch	3RAP680EM60ST

SPARE PARTS

Cooling element	3RNL680A
Frame	3CNAP680EM.1
Electric fan 380-415V 50Hz	1VNAP680EM50
Electric fan 460V 60 Hz	1VNAP680EM60
Thermo-switch 47-36	1TRM 47-36
Thermo-switch 60-49	1TRM 60-49

AP 730 EM

AIR-OIL HEAT EXCHANGERS MARINE USE EM TYPE
SCAMBIATORI ARIA-OLIO CON VENTILATORE AC USO MARINO SERIE EM



- Dimensions and technical characteristics are not binding

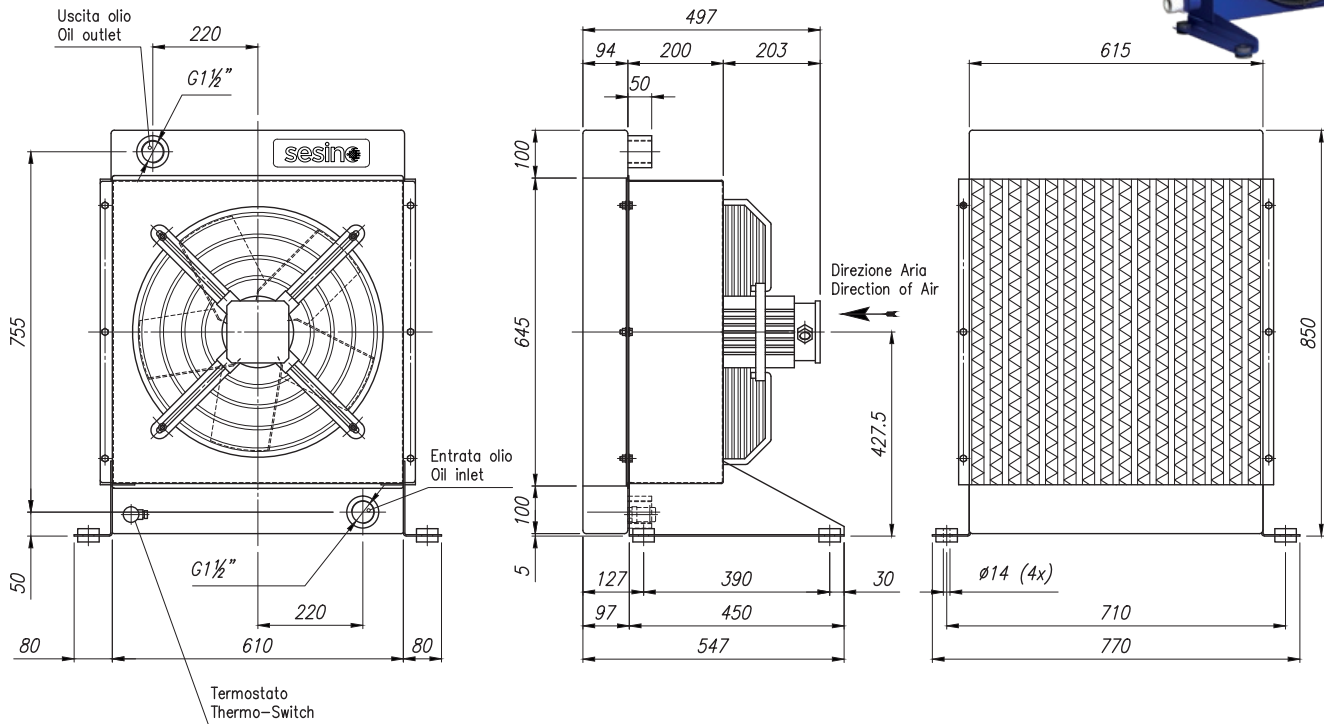

Static working pressure = 20 bar

Test pressure = 35 bar

CODE	OIL FLOW l/min	CAP. l	VOLT. V	FREQ. Hz	POWER W	CURRENT A	AIR FLOW m ³ /h	PROT. IP	NOISE LEV. dB(A)	WEIGHT kg	Ø FAN mm	TEMP. °C
3RAP730EM50ST	100-350	16	220-240(Δ) / 380-415	50	725	1,34	7800	56	75	78	500	-20/+40
3RAP730EM60ST	100-350	16	460 (Y)	60	816	1,27	8200	56	75	78	500	-20/+40

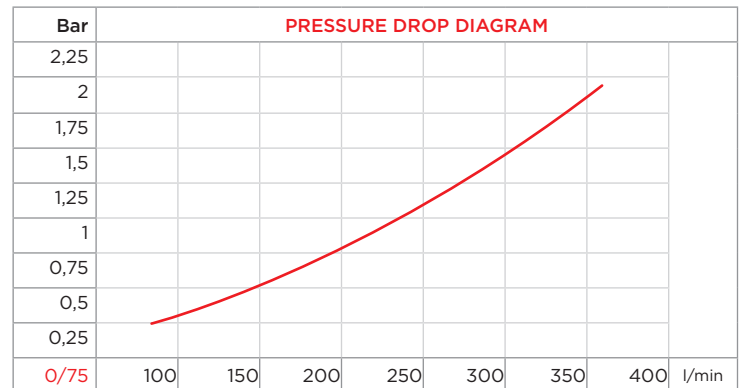
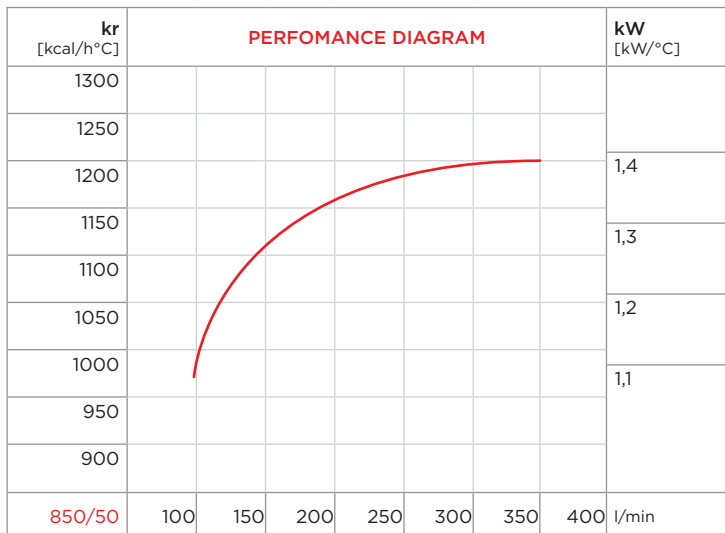

CORRECTION FACTOR

cSt	22	30	46	68	100	150	220
f	0,6	1	1,5	2,3	3,5	5	7

PURCHASE CODES

AP 730 EM three-phase 380-415V 50Hz with thermo-switch	3RAP730EM50T247 3RAP730EM50T260
AP 730 EM three-phase 460V 60 Hz with thermo-switch	3RAP730EM60T247 3RAP730EM60T260
AP 730 EM three-phase 380-415V 50Hz without thermo-switch	3RAP730EM50ST
AP 730 EM three-phase 460V 60 Hz without thermo-switch	3RAP730EM60ST

SPARE PARTS

Cooling element	3RNL730A
Frame	3CNAP730EM.1
Electric fan 380-415V 50Hz	1VNAP680EM50
Electric fan 460V 60 Hz	1VNAP680EM60
Thermo-switch 47-36	1TRM 47-36
Thermo-switch 60-49	1TRM 60-49

AP 830 EM

AIR-OIL HEAT EXCHANGERS MARINE USE EM TYPE
SCAMBIATORI ARIA-OLIO CON VENTILATORE AC USO MARINO SERIE EM



- Dimensions and technical characteristics are not binding

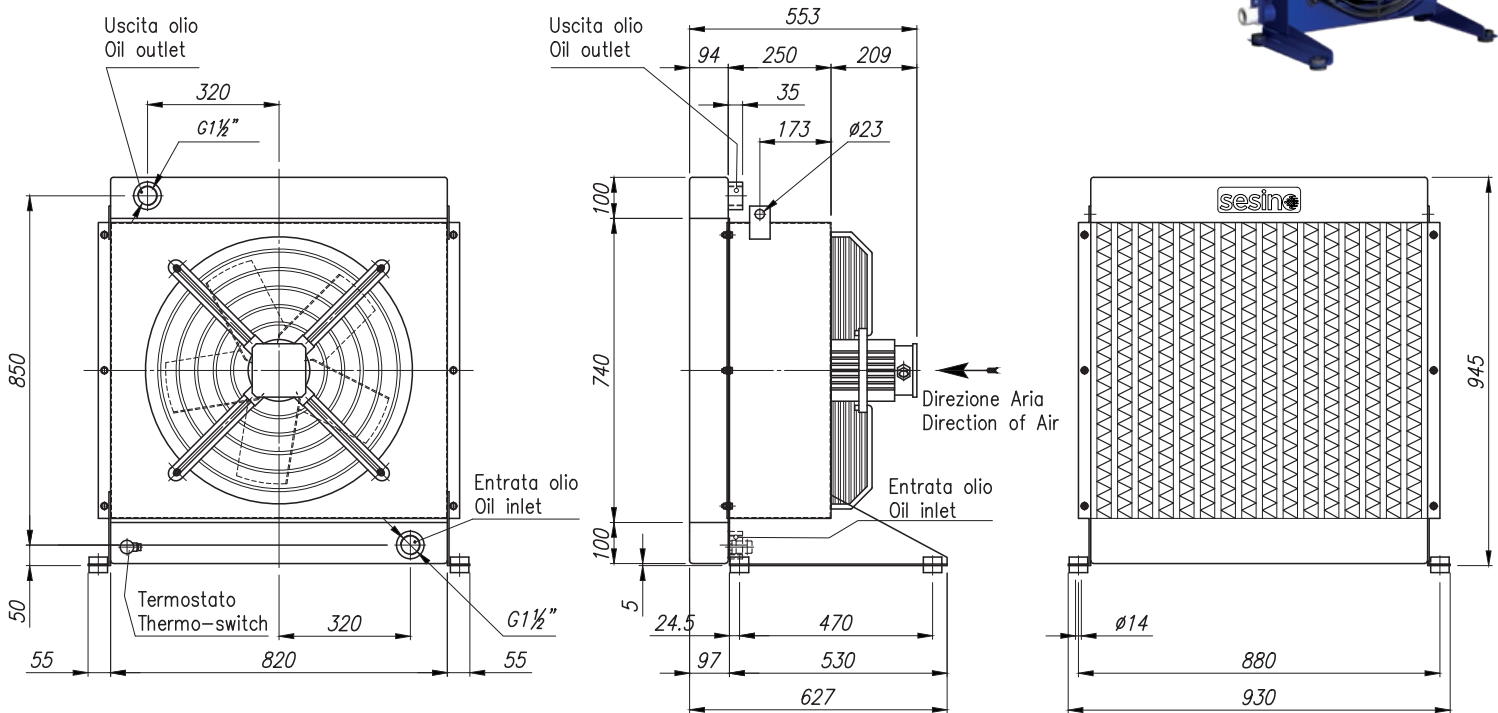

Static working pressure = 20 bar

Test pressure = 35 bar

CODE	OIL FLOW l/min	CAP. l	VOLT. V	FREQ. Hz	POWER W	CURRENT A	AIR FLOW m³/h	PROT. IP	NOISE LEV. dB(A)	WEIGHT kg	ø FAN mm	TEMP. °C
3RAP830EM50ST	150-400	20	220-240(Δ) / 380-415 (Y)	50	1050	2	10000	56	75	86	500	
3RAP830EM60ST	150-400	20	460 (Y)	60	1417	2,44	10600	56	75	86	500	

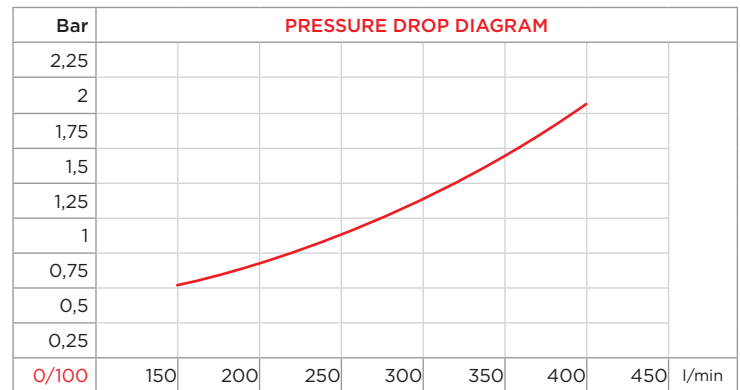
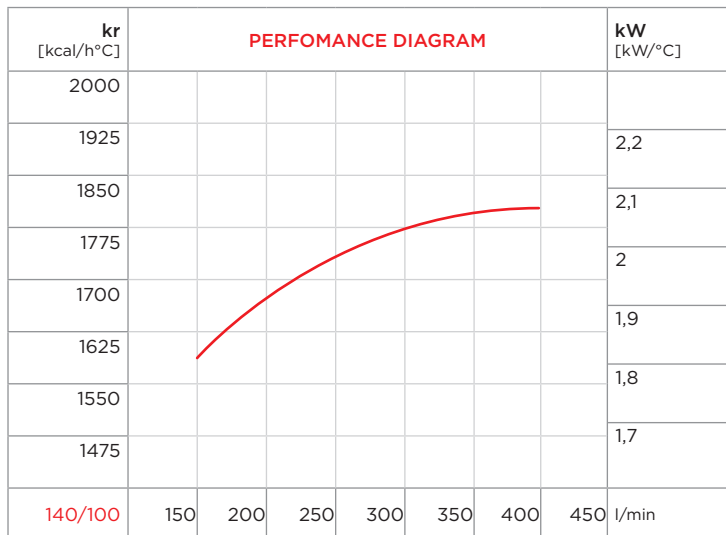

CORRECTION FACTOR

cSt	22	30	46	68	100	150	220
f	0,6	1	1,5	2,3	3,5	5	7

PURCHASE CODES

AP 830 EM three-phase 380-415V 50Hz with thermo-switch	3RAP830EM50T247 3RAP830EM50T260
AP 830 EM three-phase 460V 60 Hz with thermo-switch	3RAP830EM60T247 3RAP830EM60T260
AP 830 EM three-phase 380-415V 50Hz without thermo-switch	3RAP830EM50ST
AP 830 EM three-phase 460V 60 Hz without thermo-switch	3RAP830EM60ST

SPARE PARTS

Cooling element	3RNL830A
Frame	3CNAP830EM.1
Electric fan 380-415V 50Hz	1VNAP830EM50
Electric fan 460V 60 Hz	1VNAP830EM60
Thermo-switch 47-36	1TRM 47-36
Thermo-switch 60-49	1TRM 60-49

AP 2/680 EM

AIR-OIL HEAT EXCHANGERS MARINE USE EM TYPE
SCAMBIATORI ARIA-OLIO CON VENTILATORE AC USO MARINO SERIE EM



- Dimensions and technical characteristics are not binding

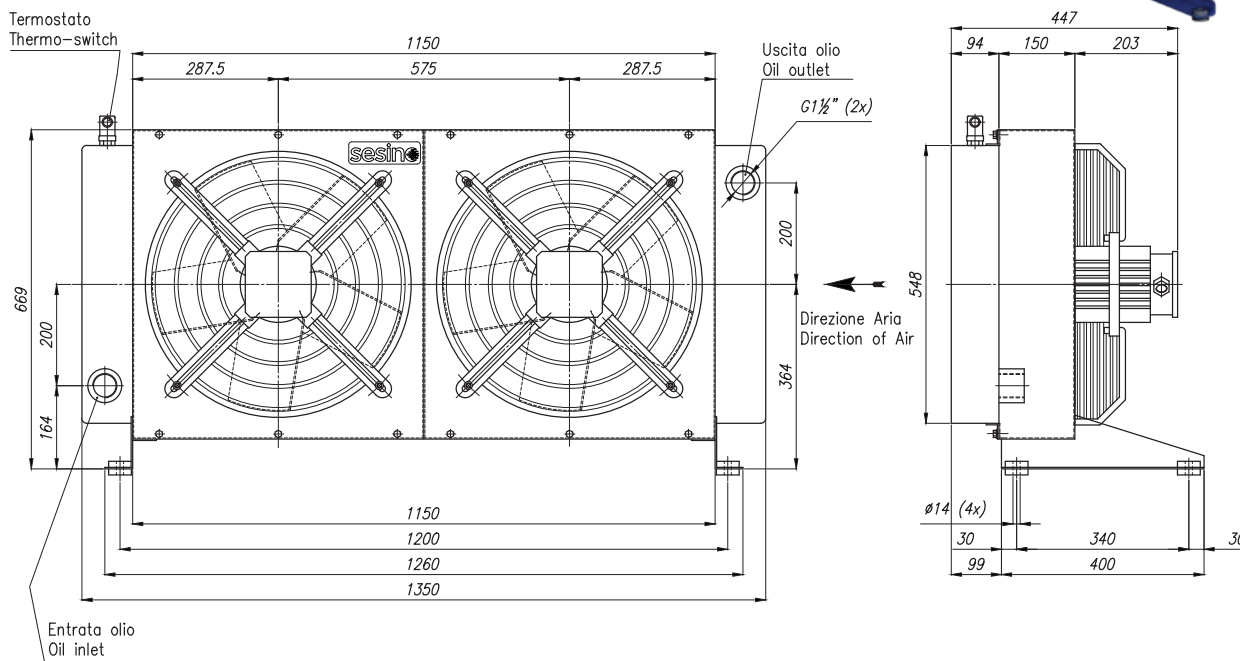

Static working pressure = 20 bar

Test pressure = 35 bar

CODE	OIL FLOW l/min	CAP. l	VOLT. V	FREQ. Hz	POWER W	CURRENT A	AIR FLOW m³/h	PROT. IP	NOISE LEV. dB(A)	WEIGHT kg	Ø FAN mm	TEMP. °C
3RAP2/680EM50ST	100-300	28	220-240(Δ) / 380-415	50	2x 725	2x 1,34	2x 7500	56	77	125	500	-20/+40
3RAP2/680EM60ST	100-300	28	460 (Y)	60	2x 816	2x 1,27	2x 7900	56	77	125	500	-20/+40

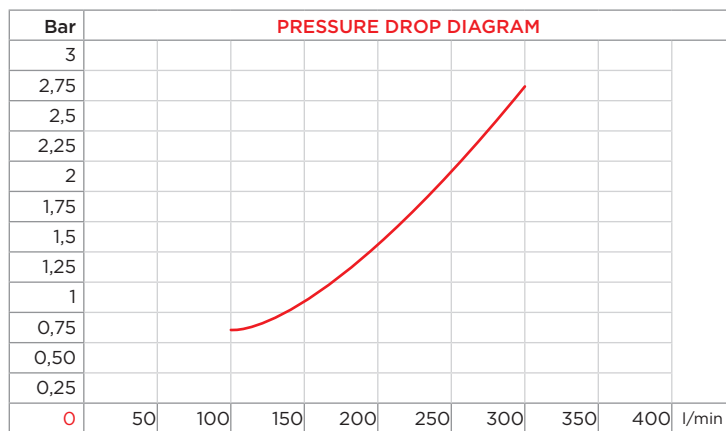
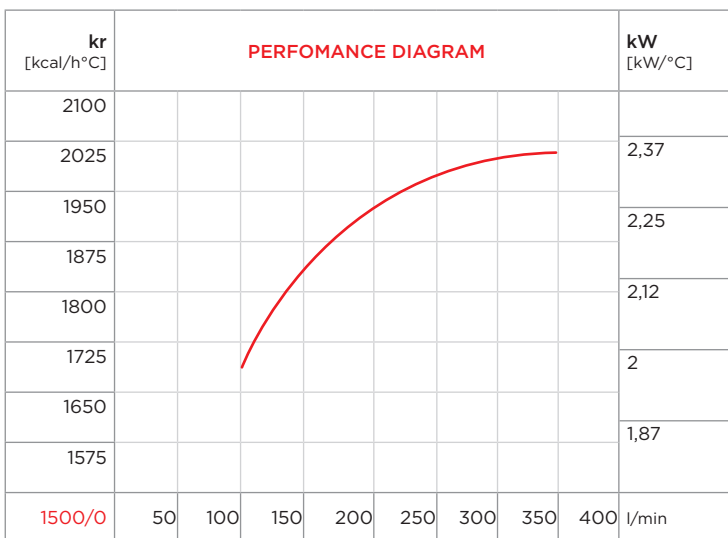

CORRECTION FACTOR

cSt	22	30	46	68	100	150	220
f	0,6	1	1,5	2,3	3,5	5	7

PURCHASE CODES

AP 2/680 EM three-phase 380-415V 50Hz with thermo-switch	3RAP2680EM50T47 3RAP2680EM50T60
AP 2/680 EM three-phase 460V 60 Hz with thermo-switch	3RAP2680EM60T47 3RAP2680EM60T60
AP 2/680 EM three-phase 380-415V 50Hz without thermo-switch	3RAP2/680EM50ST
AP 2/680 EM three-phase 460V 60 Hz without thermo-switch	3RAP2/680EM60ST

SPARE PARTS

Cooling element	3RNL2/680A
Frame	3CNAP2/680EM.1
Electric fan 380-415V 50Hz	1VNAP680EM50
Electric fan 460V 60 Hz	1VNAP680EM60
Thermo-switch 47-36	1TRM 47-36
Thermo-switch 60-49	1TRM 60-49



AP 2/730 EM

AIR-OIL HEAT EXCHANGERS MARINE USE EM TYPE
SCAMBIATORI ARIA-OLIO CON VENTILATORE AC USO MARINO SERIE EM



- Dimensions and technical characteristics are not binding

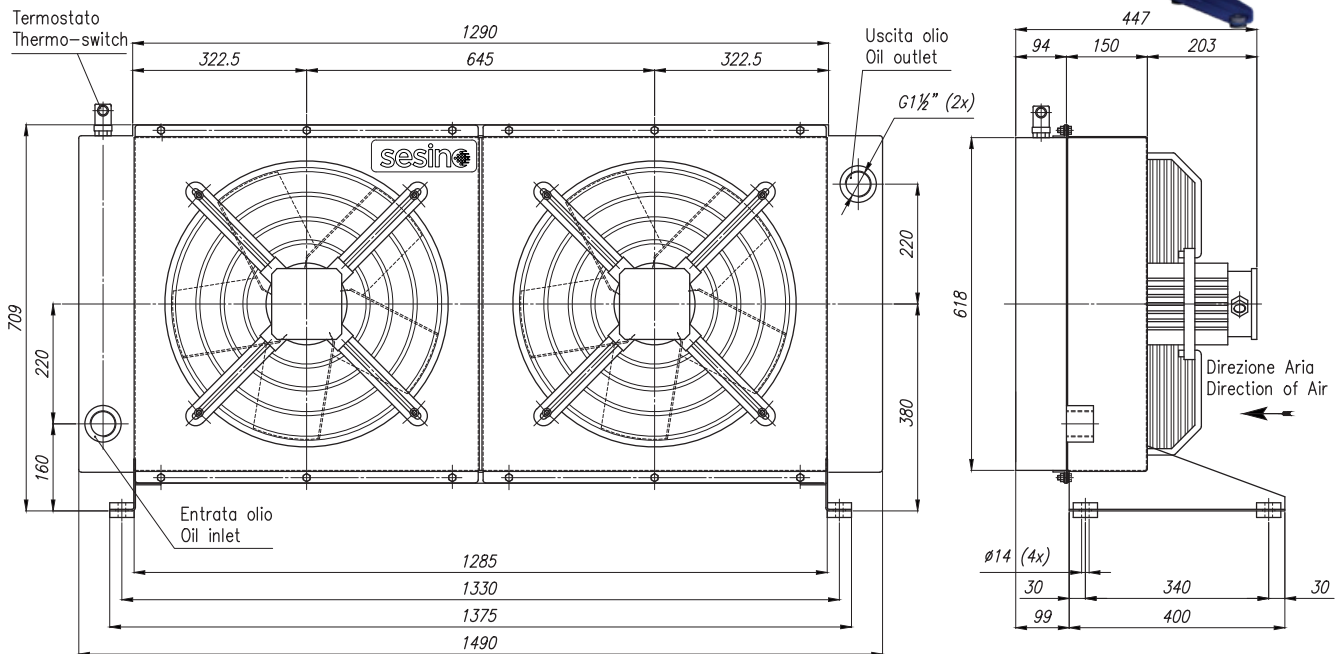

Static working pressure = 20 bar	Test pressure = 35 bar
----------------------------------	------------------------

CODE	OIL FLOW l/min	CAP. l	VOLT. V	FREQ. Hz	POWER W	CURRENT A	AIR FLOW m ³ /h	PROT. IP	NOISE LEV. dB(A)	WEIGHT kg	ø FAN mm	TEMP. °C
3RAP2/730EM50ST	100-350	30	220-240(Δ) / 380-415	50	2x 725	2x 1,34	2x 7800	56	77	145	500	-20/+40
3RAP2/730EM60ST	100-350	30	460 (Y)	60	2x 816	2x 1,27	2x 8200	56	77	145	500	-20/+40

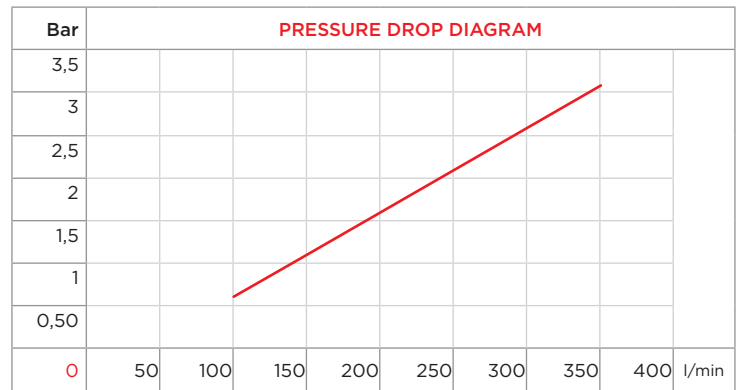
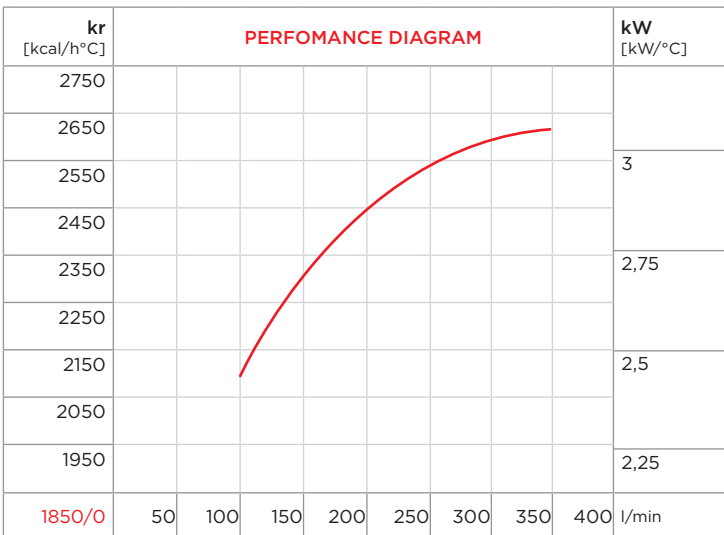

CORRECTION FACTOR							
cSt	22	30	46	68	100	150	220
f	0,6	1	1,5	2,3	3,5	5	7

PURCHASE CODES

AP 2/730 EM three-phase 380-415V 50Hz with thermo-switch	3RAP2730EM50T47 3RAP2730EM50T60
AP 2/730 EM three-phase 460V 60HZ with thermo-switch	3RAP2730EM60T47 3RAP2730EM60T60
AP 2/730 EM three-phase 380-415V 50Hz without thermo-switch	3RAP2/730EM50ST
AP 2/730 EM three-phase 460V 60HZ without thermo-switch	3RAP2/730EM60ST

SPARE PARTS

Cooling element	3RNL2/730A
Frame	3CNAP2/730EM.1
Electric fan 380-415V 50Hz	1VNAP680EM50
Electric fan 460V 60Hz	1VNAP680EM60
Thermo-switch 47-36	1TRM 47-36
Thermo-switch 60-49	1TRM 60-49

AP 2/830 EM

AIR-OIL HEAT EXCHANGERS MARINE USE EM TYPE
SCAMBIATORI ARIA-OLIO CON VENTILATORE AC USO MARINO SERIE EM



- Dimensions and technical characteristics are not binding

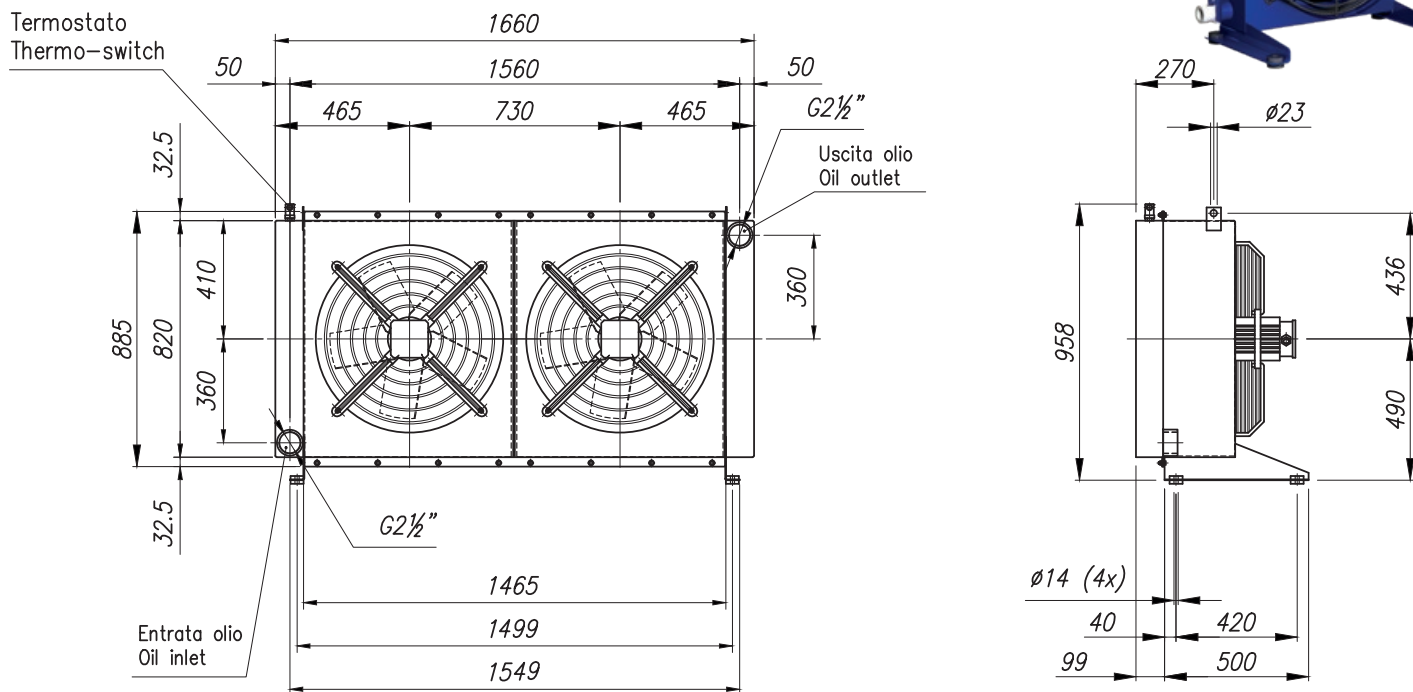

Static working pressure = 20 bar

Test pressure = 35 bar

CODE	OIL FLOW	CAP.	VOLT.	FREQ.	POWER	CURRENT	AIR FLOW	PROT.	NOISE LEV.	WEIGHT	ø FAN	TEMP.
	l/min	l	V	Hz	W	A	m ³ /h	IP	dB(A)	kg	mm	°C
3RAP2/830EM5OST	150-400	40	220-240(Δ) / 380-415	50	2x 1050	2x 2	2x 10000	56	75	186	560	-20/+40
3RAP2/830EM6OST	150-400	40	460 (Y)	60	2x 1417	2x 2,44	2x 10600	56	75	186	560	-20/+40

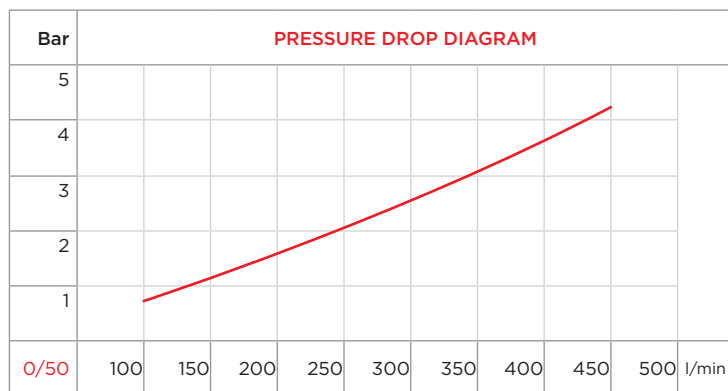
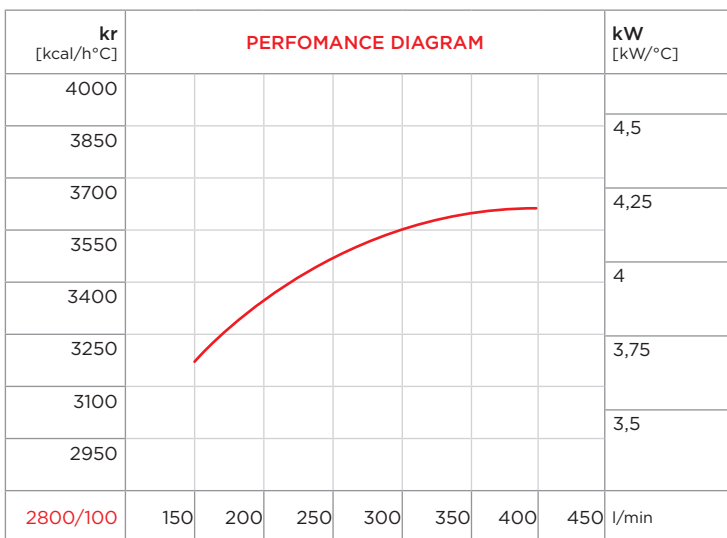

CORRECTION FACTOR							
cSt	22	30	46	68	100	150	220
f	0,6	1	1,5	2,3	3,5	5	7

PURCHASE CODES

AP 2/830 EM three-phase 380-415V 50Hz with thermo-switch	3RAP2830EM50T47 3RAP2830EM50T60
AP 2/830 EM three-phase 460V 60HZ with thermo-switch	3RAP2830EM60T47 3RAP2830EM60T60
AP 2/830 EM three-phase 380-415V 50Hz without thermo-switch	3RAP2/830EM5OST
AP 2/830 EM three-phase 460V 60HZ without thermo-switch	3RAP2/830EM6OST

SPARE PARTS

Cooling element	3RNL2/830A
Frame	3CNAP2/830EM.1
Electric fan 380-415V 50Hz	1VNAP830EM50
Electric fan 460V 60Hz	1VNAP830EM60
Thermo-switch 47-36	1TRM 47-36
Thermo-switch 60-49	1TRM 60-49



AP 3/830 EM

AIR-OIL HEAT EXCHANGERS MARINE USE EM TYPE
SCAMBIATORI ARIA-OLIO CON VENTILATORE AC USO MARINO SERIE EM



- Dimensions and technical characteristics are not binding

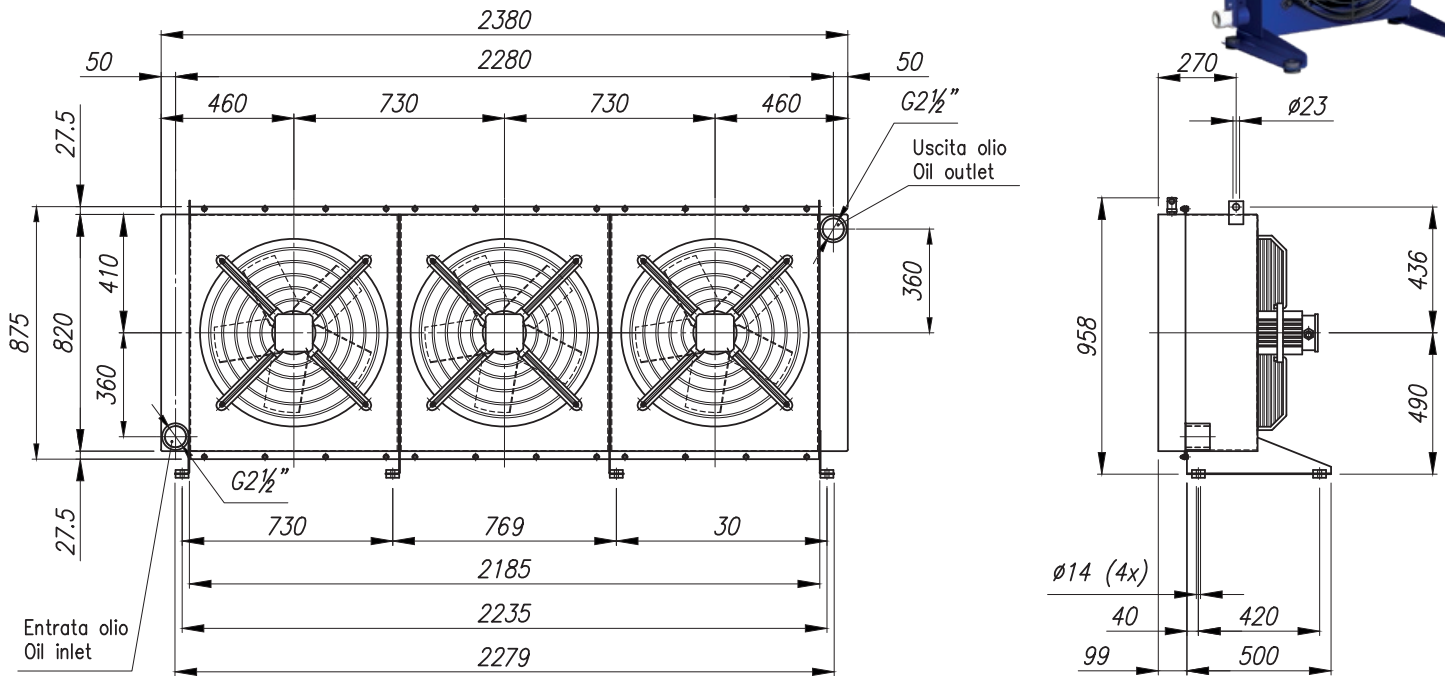

Static working pressure = 20 bar

Test pressure = 35 bar

CODE	OIL FLOW l/min	CAP. l	VOLT. V	FREQ. Hz	POWER W	CURRENT A	AIR FLOW m ³ /h	PROT. IP	NOISE LEV. dB(A)	WEIGHT kg	Ø FAN mm	TEMP. °C
3RAP3/830EM50ST	150-400	60	220-240(Δ) / 380-415	50	3x 1050	3x 2	3x 10000	56	78	268	560	-20/+40
3RAP3/830EM60ST	150-400	60	460 (Y)	60	3x 1417	3x 2,44	3x 10600	56	78	268	560	-20/+40

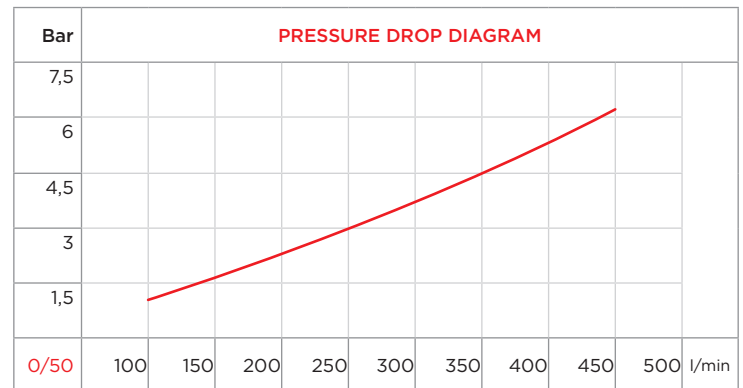
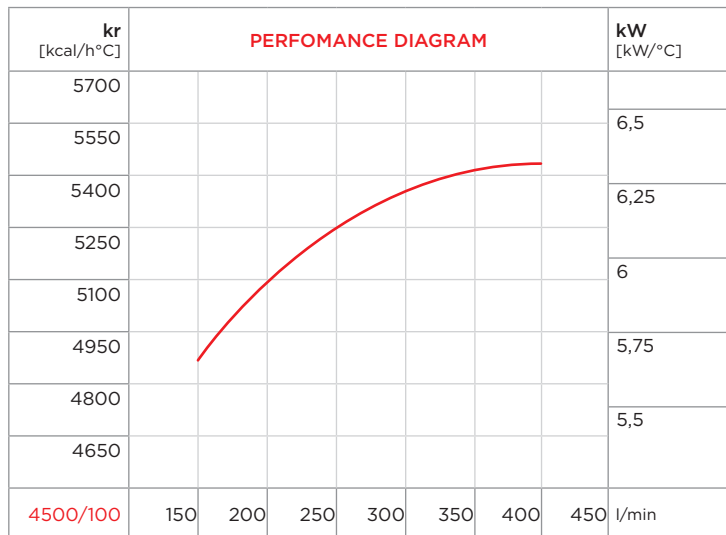

CORRECTION FACTOR

cSt	22	30	46	68	100	150	220
f	0,6	1	1,5	2,3	3,5	5	7

PURCHASE CODES

AP 3/830 EM three-phase 380-415V 50Hz with thermo-switch	3RAP3830EM50T47 3RAP3830EM50T60
AP 3/830 EM three-phase 460V 60HZ with thermo-switch	3RAP3830EM60T47 3RAP3830EM60T60
AP 3/830 EM three-phase 380-415V 50Hz without thermo-switch	3RAP3/830EM50ST
AP 3/830 EM three-phase 460V 60HZ without thermo-switch	3RAP3/830EM60ST

SPARE PARTS

Cooling element	3RNL3/830A
Frame	3CNAP3 /830EM.1
Electric fan 380-415V 50Hz	1VNAP830EM50
Electric fan 460V 60Hz	1VNAP830EM60
Thermo-switch 47-36	1TRM 47-36
Thermo-switch 60-49	1TRM 60-49



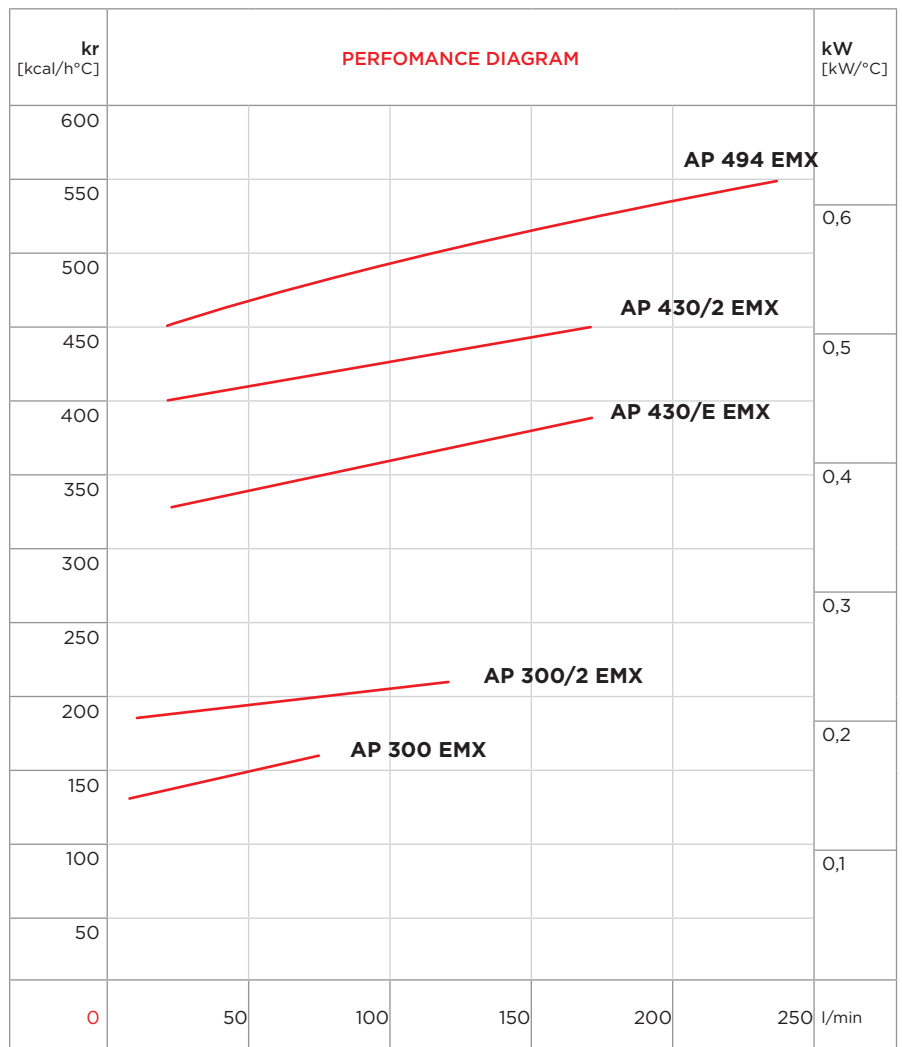
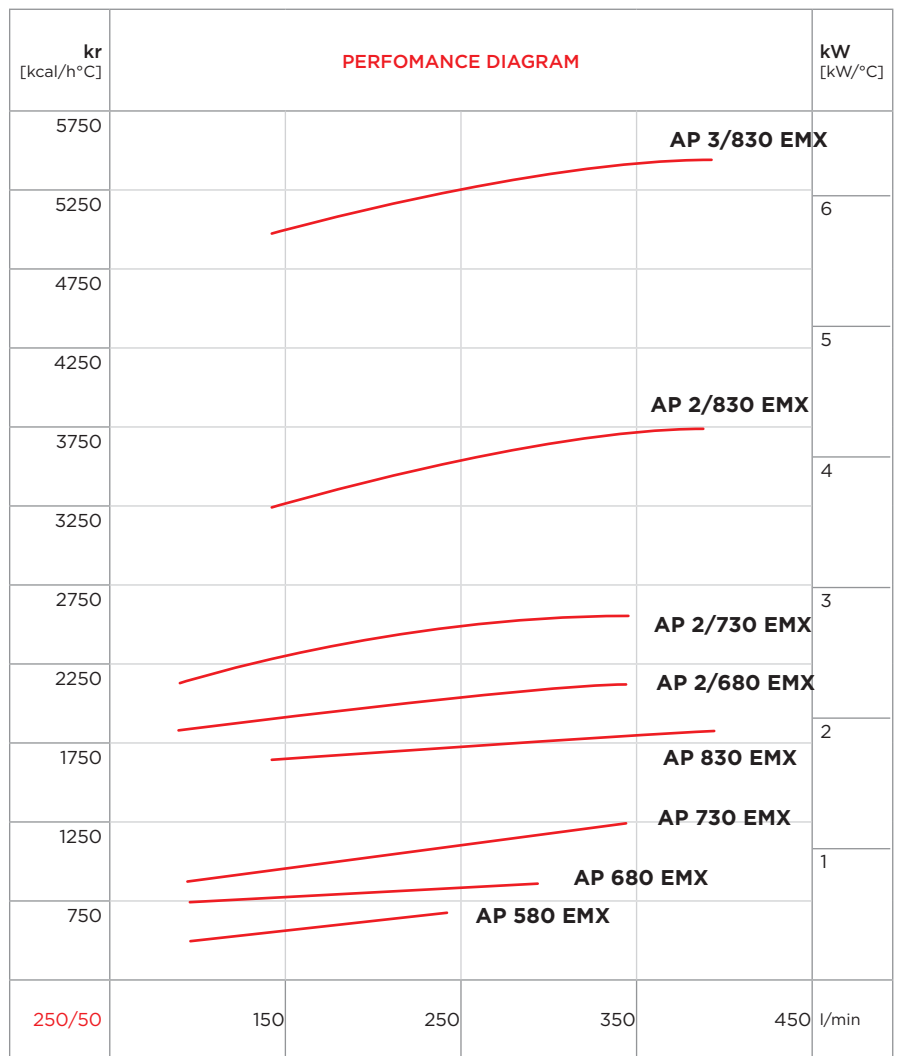

AC MOTOR AIR-OIL HEAT EXCHANGERS MARINE USE AND ATEX REGULATION EMX TYPE

SCAMBIATORI DI CALORE ARIA OLIO CON VENTILATORE A CORRENTE ALTERNATA
USO MARINO NORME ATEX SERIE EMX



The advantage of using air into the cooling of oleo hydraulic systems has its bases on the following facts:

- There is no need of water
- The system is independent of the connection to the water main
- Lower working costs in comparison with the water-oil exchangers, even if the starting investment is higher
- Possibility to use warm air to heat the room in winter.
- The particular structure of the cooling element allows great thermic performances and pressure resistance.

Maximum working static pressure: 20 bar; test pressure: 35 bar.

It is always recommended to assemble in parallel with the exchanger a by-pass valve to avoid extreme counter-pressures, particularly when the machine is started with cold oil. On the contrary, it is not useful to use a check valve as by-pass to protect the exchanger from pressure's peaks, since the inertia of the valve itself is too high in comparison with the speed of the pressure waves that occur into the oleo hydraulic systems.

The flow rates shown in the tables are the ones recommended for the exchanger proper working.

The efficiency curves show the specific exchange capacity in kcal/h°C or in kW/°C according to the different oil rates. To calculate the heat quantity the different exchangers are able to dissipate it is enough to multiply such capacity by the difference between the requested oil temperature and the summer room temperature.

The heat exchangers type EMX have been designed to be used outdoors, in areas where the level of salinity in the air and the explosion risks are high.

The components are the following:

- Aluminum cooling element with anodizing and corrosion proofing treatment (SWAAT test according to ASTM G 85-94 ANNEX A3)
- Coated AISI 304 STAINLESS STEEL AISI 304 frame
- Three-phase electric fan, 400V 50Hz or 460V 60Hz according to ATEX IP 56 Category 2G, protection Ex-d class T4 Group IIB and STAINLESS STEEL AISI 304 protection grill.

For the right calculation of air-oil heat exchangers, we supply our customers with a calculation software.

The air-oil heat exchangers can be used to cool other kind of fluids, which must be compatible with aluminum and its alloys.

However, for each use, with the exception of oil cooling, we recommend to consult our Technical Department.

Il vantaggio dell'utilizzo dell'aria nel raffreddamento di impianti oleoidraulici trova le sue ragioni nei seguenti fattori:

- Non necessità l'utilizzo di acqua
- Indipendenza della macchina dalle tubazioni di allacciamento alla rete idrica
- Inferiore costo di esercizio rispetto agli scambiatori acqua-olio, anche se maggiore è l'investimento iniziale
- Possibilità di utilizzare l'aria calda in uscita per riscaldare l'ambiente nella stagione invernale
- La particolare costruzione del radiatore consente di ottenere notevoli rese termiche e forte resistenza alla pressione.

Pressione massima statica di funzionamento: 20 bar; pressione di collaudo: 35 bar.

È sempre consigliabile montare in parallelo allo scambiatore una valvola di by-pass per evitare eccessive contropressioni soprattutto al momento dell'avviamento della macchina con olio freddo. Non è invece conveniente utilizzare una valvola di ritegno come by-pass per proteggere lo scambiatore dai picchi di pressione in quanto l'inerzia della valvola stessa è troppo alta rispetto alla velocità delle onde di pressione che si sviluppano all'interno dell'olio degli impianti oleoidraulici. Le portate olio indicate nelle tabelle sono quelle consigliate per il buon funzionamento dello scambiatore.

Le curve di rendimento forniscono la potenzialità di scambio specifica in kcal/h°C o in kW/h°C in funzione della portata olio; per calcolare la quantità di calore che i vari scambiatori sono in grado di disperdere, è sufficiente moltiplicare tale potenzialità per la differenza tra le temperature dell'olio desiderata e dell'aria ambiente massima estiva.

Gli scambiatori della serie EMX sono stati concepiti per essere installati all'aperto in zone dove la concentrazione di salinità dell'aria è elevata ed è alto il rischio di esplosione

I componenti sono i seguenti:

- Radiatore in alluminio con trattamento di anodizzazione anticorrosione (SWAAT test secondo norme ASTM G 85-94 ANNEX A3)
- Telaio in acciaio inossidabile AISI 304 verniciato
- Motore elettrico trifase 400V 50Hz o 460V 60Hz norme ATEX IP 56 Categoria 2G protezione Ex-d classe T4 Gruppo IIB e rete di protezione in acciaio inossidabile

Per il calcolo degli scambiatori aria-olio è disponibile il nostro software. Gli scambiatori aria-olio possono essere utilizzati per raffreddare altri tipi di fluidi, a condizione che essi siano compatibili con l'alluminio e le sue leghe.

Consigliamo comunque, per qualsiasi impiego che non sia il raffreddamento dell'olio, di contattare il nostro Ufficio Tecnico.

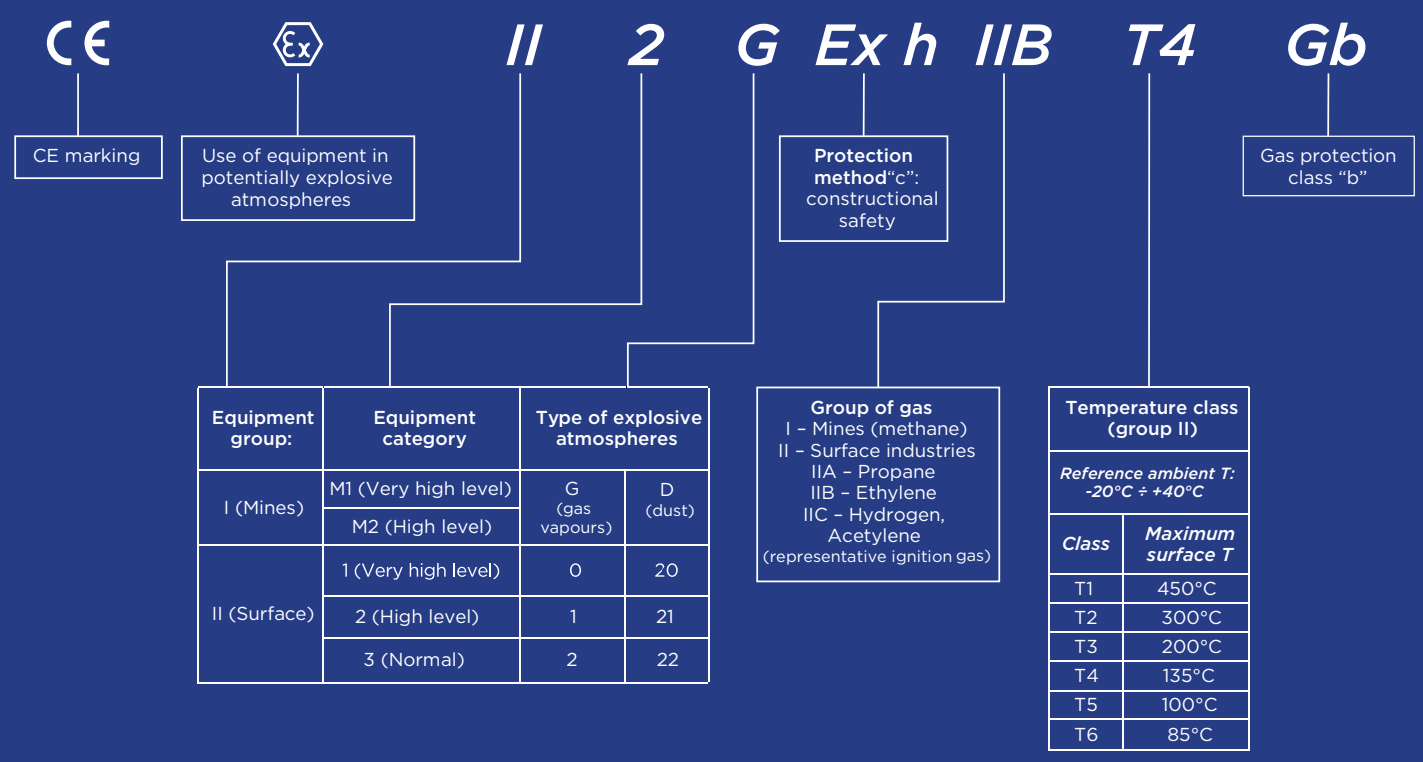
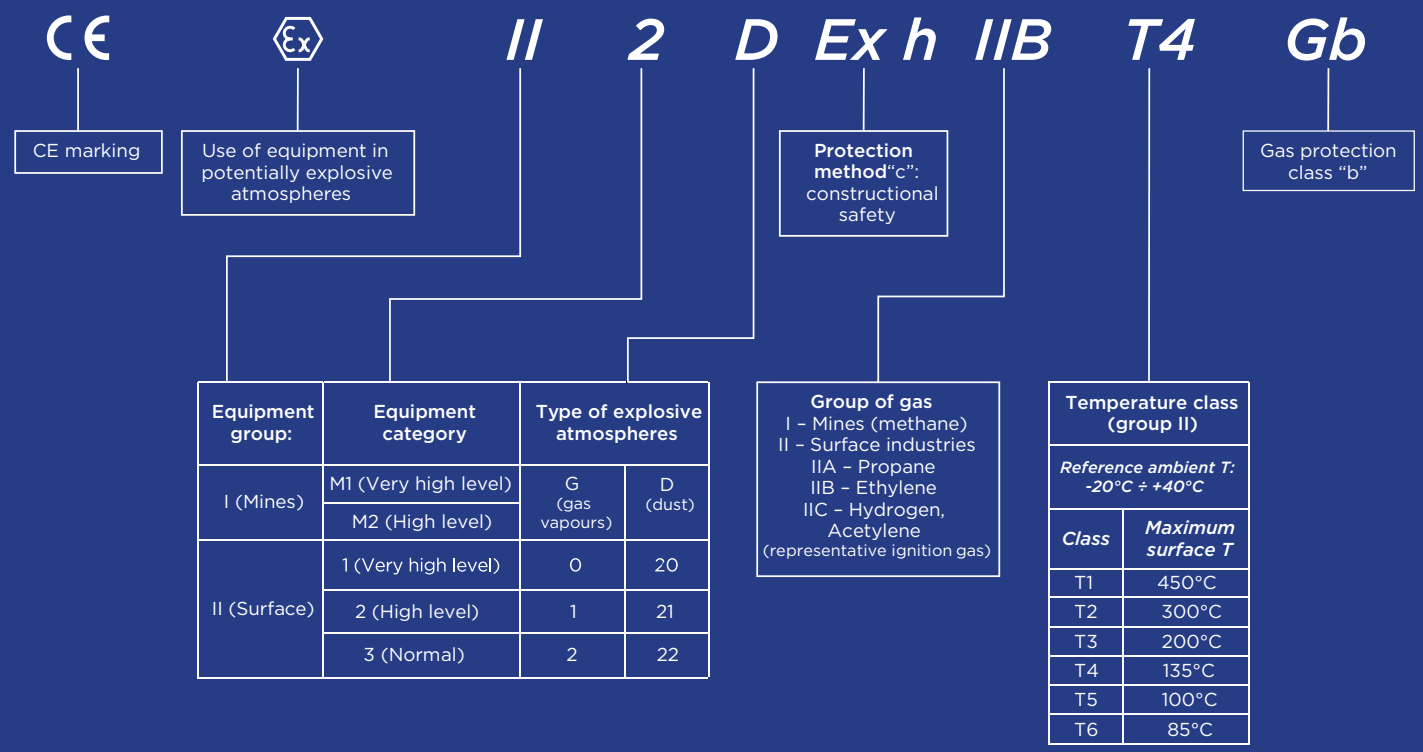
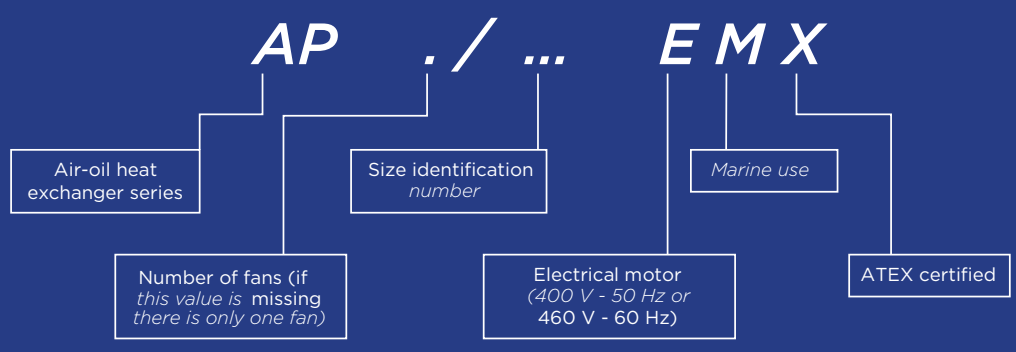

AP 300 EMX

AC MOTOR AIR-OIL HEAT EXCHANGERS
MARINE USE AND ATEX REGULATION EMX TYPE
SCAMBIATORI DI CALORE ARIA OLIO CON VENTILATORE A
CORRENTE ALTERNATA USO MARINO NORME ATEX SERIE EMX



- Dimensions and technical characteristics are not binding

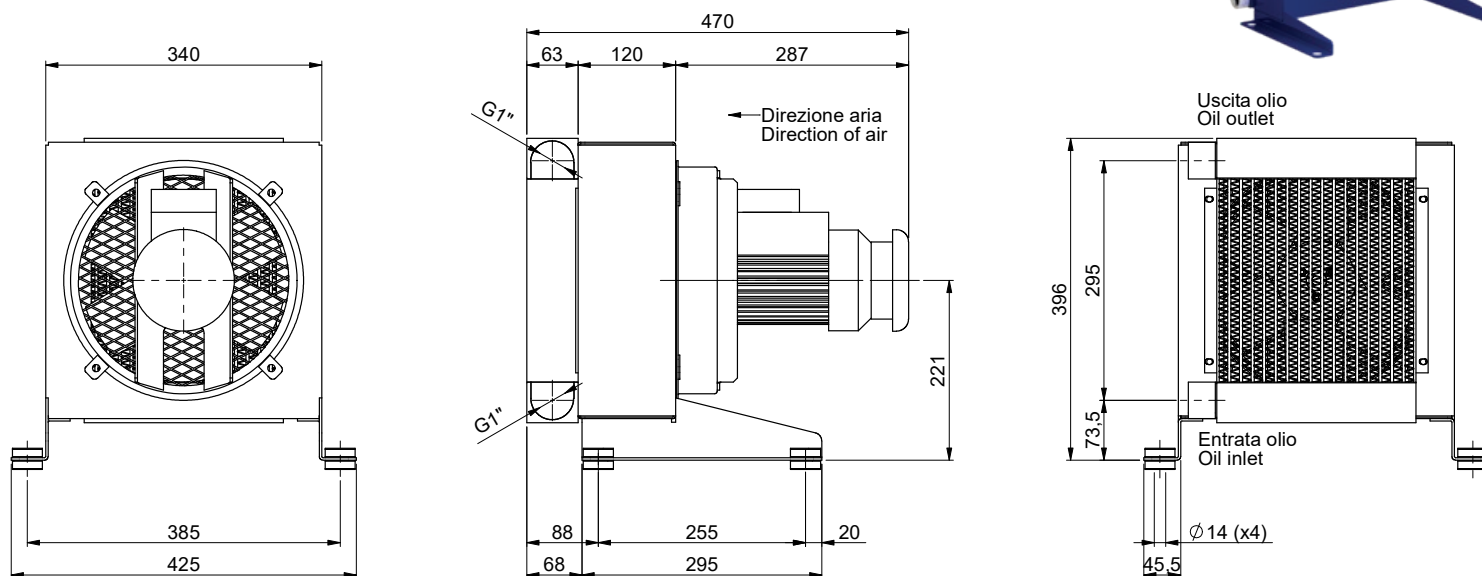

Static working pressure = 20 bar

Test pressure = 35 bar

CODE	OIL FLOW l/min	CAP. l	VOLT. V	FREQ. Hz	POWER W	CURRENT A	AIR FLOW m³/h	PROT. IP	NOISE LEV. dB(A)	WEIGHT kg	ø FAN mm	TEMP. °C
3RAP300EMX50	10-80	2	220-240(Δ) / 380-415 (Y)	50	180	0,75	1500	56	81	30	250	-20/+40
3RAP300EMX60	10-80	2	460 (Y)	60	285	0,6	1580	56	83	30	250	-20/+40

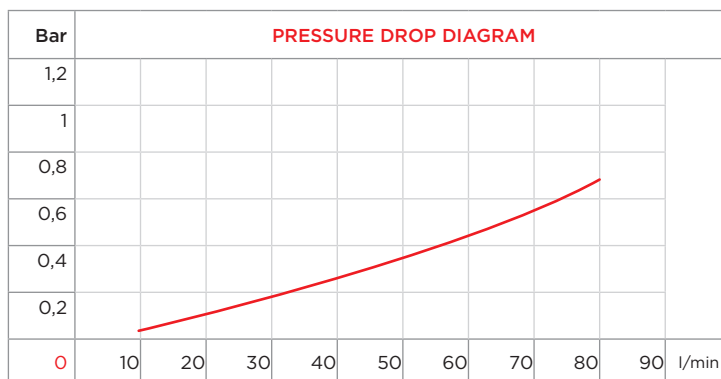
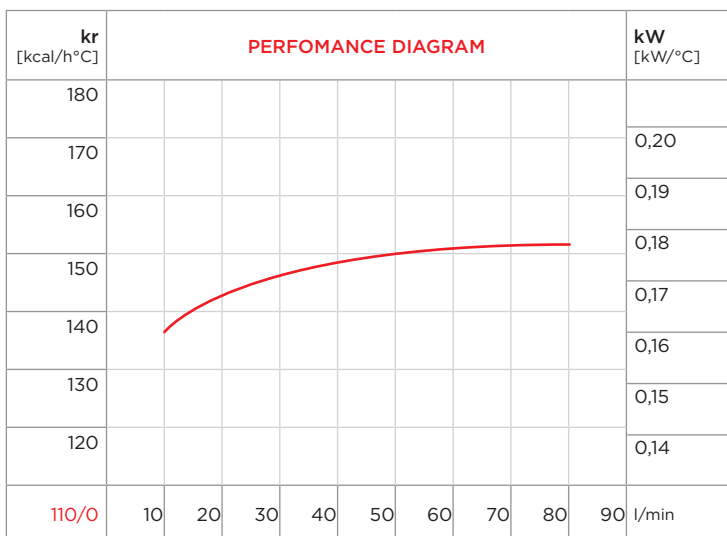

CORRECTION FACTOR

cSt	22	30	46	68	100	150	220
f	0,6	1	1,5	2,3	3,5	5	7

PURCHASE CODES

AP 300 EMX three-phase 380-415V 50Hz	3RAP300EMX50
AP 300 EMX three-phase 460V 60HZ	3RAP300EMX60

SPARE PARTS

Cooling element	3RNL300A
Frame	3CNAP300EMX.1
Electric fan 380-415V 50Hz	1VNAP300EMX50
Electric fan 460V 60Hz	1VNAP300EMX60



AP 300/2 EMX

AC MOTOR AIR-OIL HEAT EXCHANGERS
MARINE USE AND ATEX REGULATION EMX TYPE
SCAMBIATORI DI CALORE ARIA OLIO CON VENTILATORE A
CORRENTE ALTERNATA USO MARINO NORME ATEX SERIE EMX



- Dimensions and technical characteristics are not binding

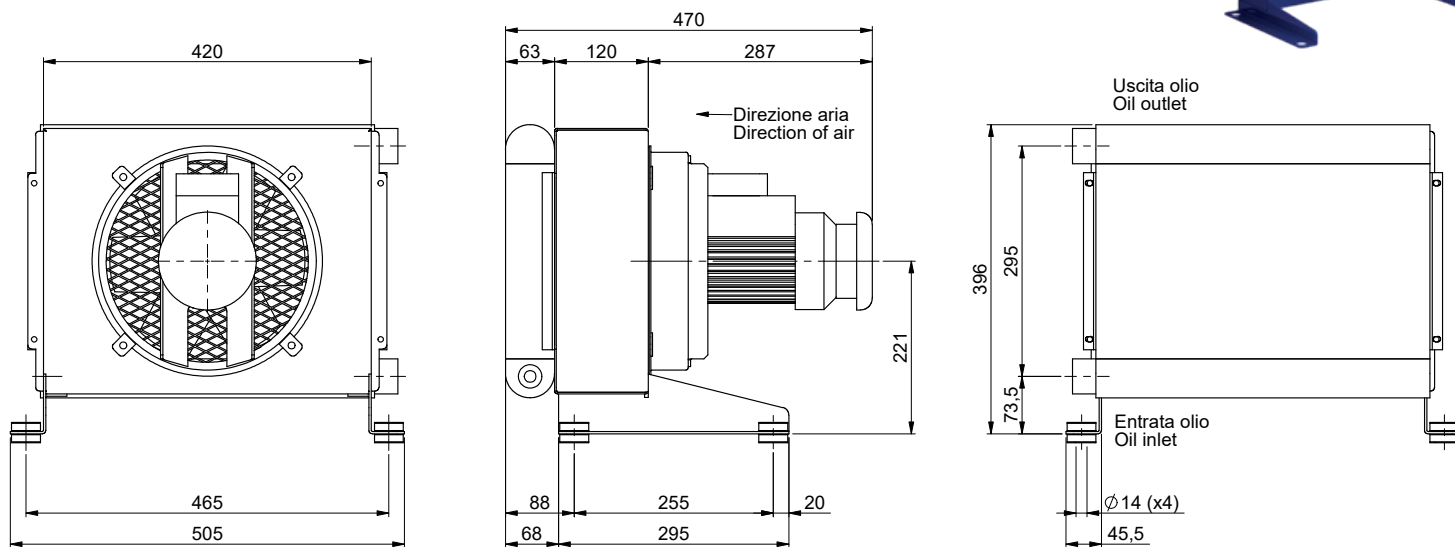

Static working pressure = 20 bar

Test pressure = 35 bar

CODE	OIL FLOW l/min	CAP. l	VOLT. V	FREQ. Hz	POWER W	CURRENT A	AIR FLOW m ³ /h	PROT. IP	NOISE LEV. dB(A)	WEIGHT kg	Ø FAN mm	TEMP. °C
3RAP302EMX50	20-160	3,6	220-240(Δ) / 380-415 (Y)	50	180	0,75	1700	56	80	35	250	-20/+40
3RAP302EMX60	20-160	2	460 (Y)	60	285	0,6	1800	56	82	35	250	-20/+40

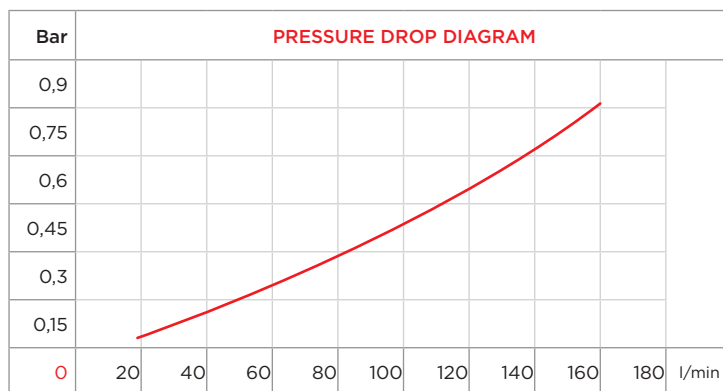
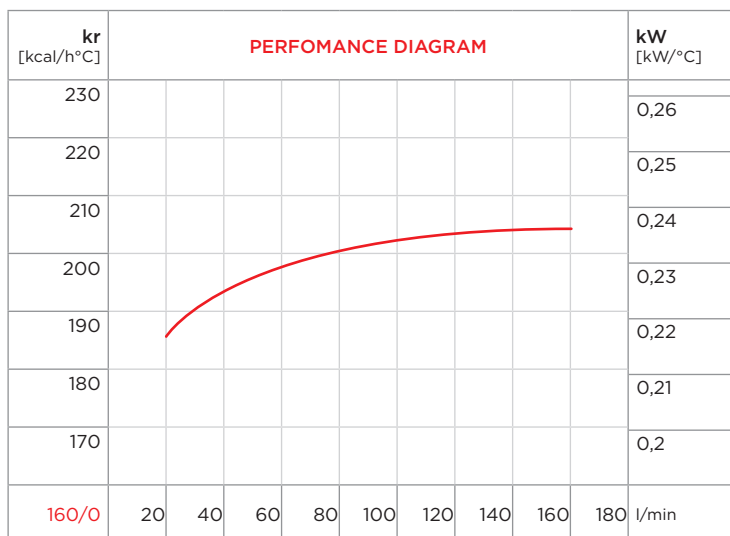

CORRECTION FACTOR

cSt	22	30	46	68	100	150	220
f	0,6	1	1,5	2,3	3,5	5	7

PURCHASE CODES

AP 300/2 EMX three-phase 380-415V 50Hz	3RAP302EMX50
AP 300/2 EMX three-phase 460V 60Hz	3RAP302EMX60

SPARE PARTS

Cooling element	3RNL302A
Frame	3CNAP302EMX.1
Electric fan 380-415V 50Hz	1VNAP300EMX50
Electric fan 460V 60Hz	1VNAP300EMX60

AP 430 EMX

AC MOTOR AIR-OIL HEAT EXCHANGERS
MARINE USE AND ATEX REGULATION EMX TYPE
SCAMBIATORI DI CALORE ARIA OLIO CON VENTILATORE A
CORRENTE ALTERNATA USO MARINO NORME ATEX SERIE EMX



- Dimensions and technical characteristics are not binding

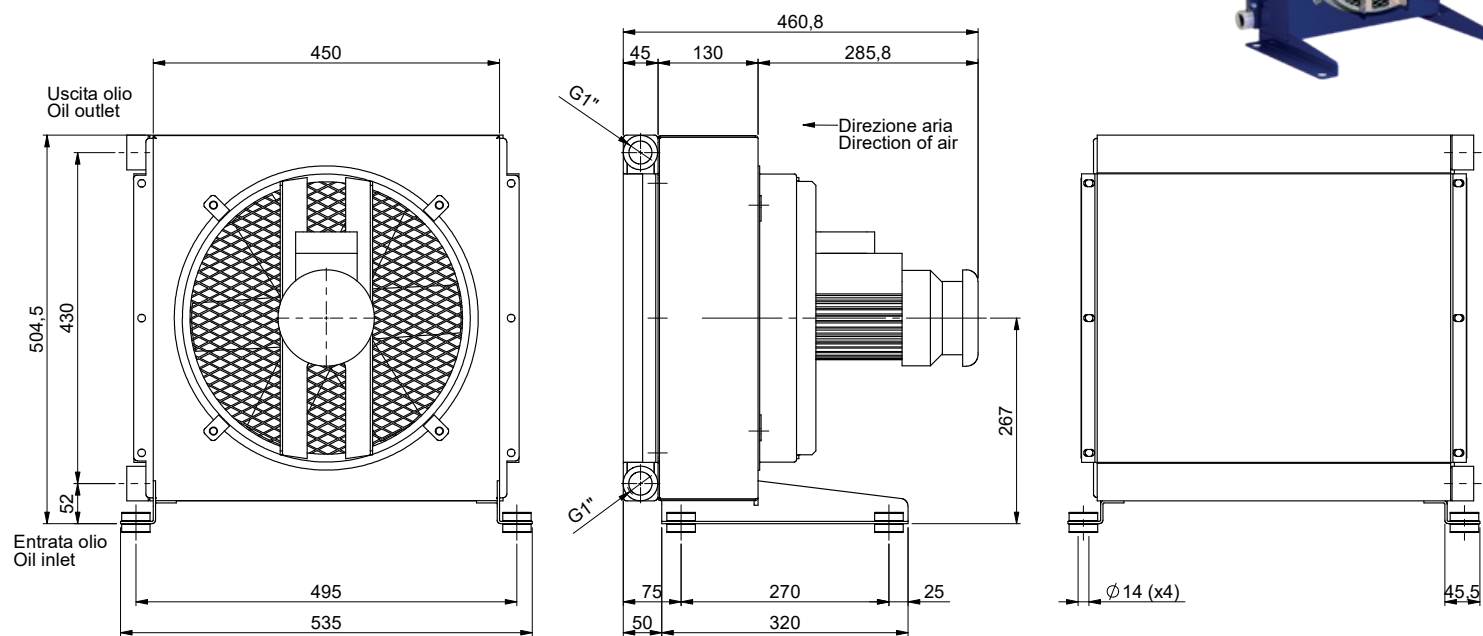

Static working pressure = 20 bar

Test pressure = 35 bar

CODE	OIL FLOW l/min	CAP. l	VOLT. V	FREQ. Hz	POWER W	CURRENT A	AIR FLOW m ³ /h	PROT. IP	NOISE LEV. dB(A)	WEIGHT kg	Ø FAN mm	TEMP. °C
3RAP430EMX50	30-180	3,6	220-240(Δ) / 380-415 (Y)	50	120	0,62	2600	56	81	38	350	-20/+40
3RAP430EMX60	30-180	3,6	460 (Y)	60	170	0,54	2800	56	83	38	350	-20/+40

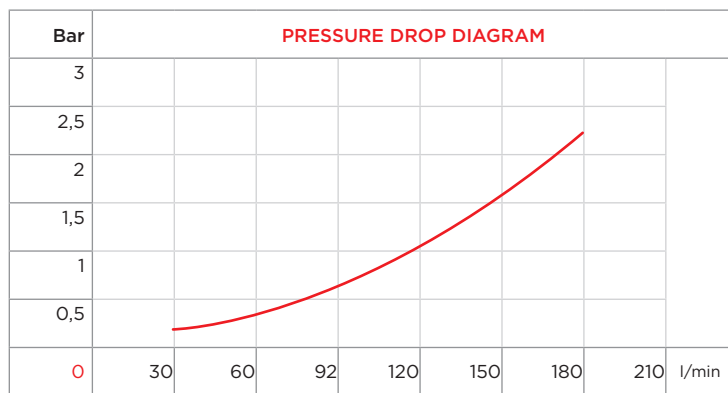
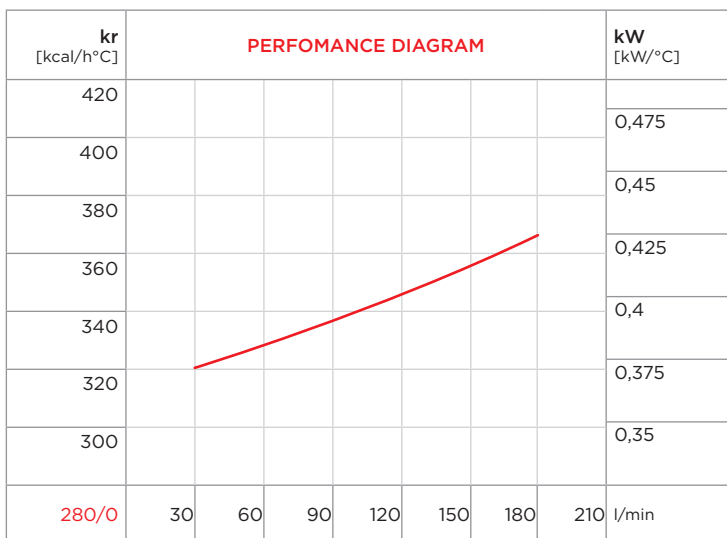

CORRECTION FACTOR

cSt	22	30	46	68	100	150	220
f	0,6	1	1,5	2,3	3,5	5	7

PURCHASE CODES

AP 430 EMX three-phase 380-415V 50Hz	3RAP430EMX50
AP 430 EMX three-phase 460V 60HZ	3RAP430EMX60

SPARE PARTS

Cooling element	3RNL430A
Frame	3CNAP430EMX.1
Electric fan 380-415V 50Hz	1VNAP430EMX50
Electric fan 460V 60Hz	1VNAP430EMX60



AP 430/2 EMX

AC MOTOR AIR-OIL HEAT EXCHANGERS
MARINE USE AND ATEX REGULATION EMX TYPE
SCAMBIATORI DI CALORE ARIA OLIO CON VENTILATORE A
CORRENTE ALTERNATA USO MARINO NORME ATEX SERIE EMX



- Dimensions and technical characteristics are not binding

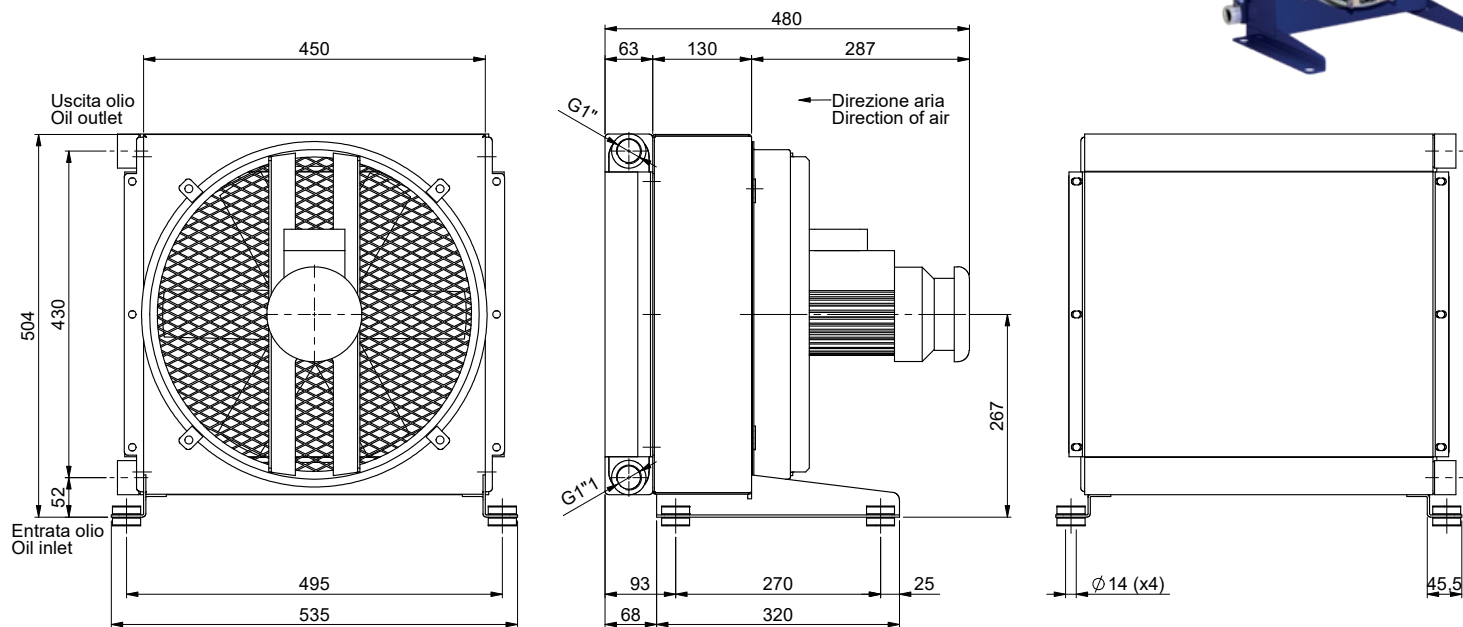

Static working pressure = 20 bar

Test pressure = 35 bar

CODE	OIL FLOW l/min	CAP. l	VOLT. V	FREQ. Hz	POWER W	CURRENT A	AIR FLOW m ³ /h	PROT. IP	NOISE LEV. dB(A)	WEIGHT kg	Ø FAN mm	TEMP. °C
3RAP432EMX50	30-180	5,5	220-240(Δ) / 380-415 (Y)	50	180	0,67	3500	56	79	40	400	-20/+40
3RAP432EMX60	30-180	5,5	460 (Y)	60	180	0,58	3700	56	81	40	400	-20/+40

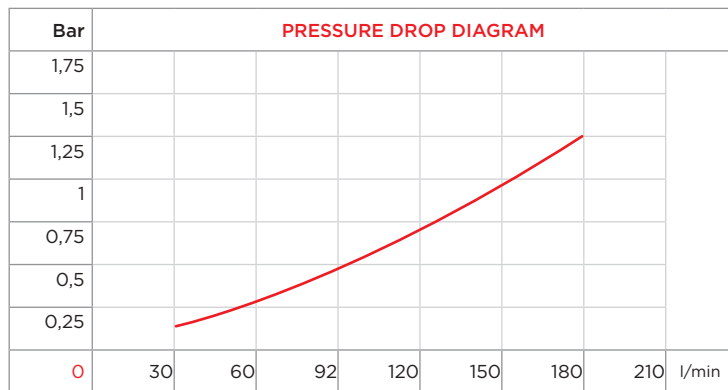
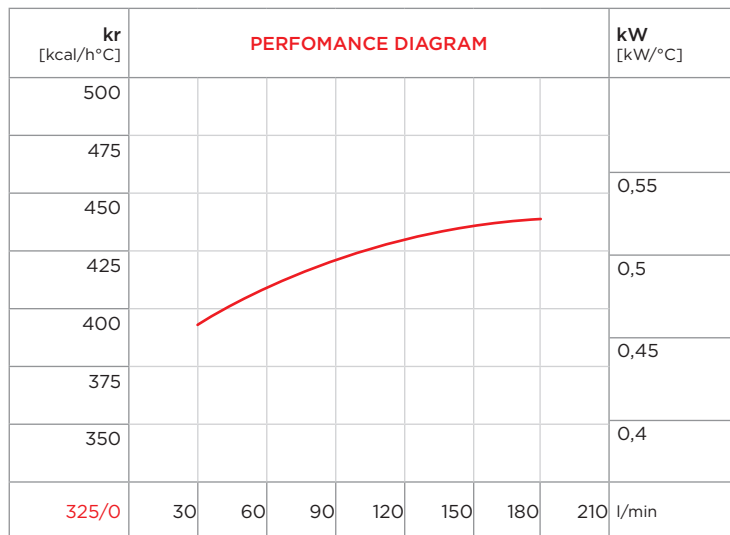

CORRECTION FACTOR

cSt	22	30	46	68	100	150	220
f	0,6	1	1,5	2,3	3,5	5	7

PURCHASE CODES

AP 430/2 EMX three-phase 380-415V 50Hz	3RAP432EMX50
AP 430/2 EMX three-phase 460V 60HZ	3RAP432EMX60

SPARE PARTS

Cooling element	3RNL432A
Frame	3CNAP432EMX.1
Electric fan 380-415V 50Hz	1VNAP432EMX50
Electric fan 460V 60Hz	1VNAP432EMX60

AP 494 EMX

AC MOTOR AIR-OIL HEAT EXCHANGERS
MARINE USE AND ATEX REGULATION EMX TYPE
SCAMBIATORI DI CALORE ARIA OLIO CON VENTILATORE A
CORRENTE ALTERNATA USO MARINO NORME ATEX SERIE EMX



- Dimensions and technical characteristics are not binding

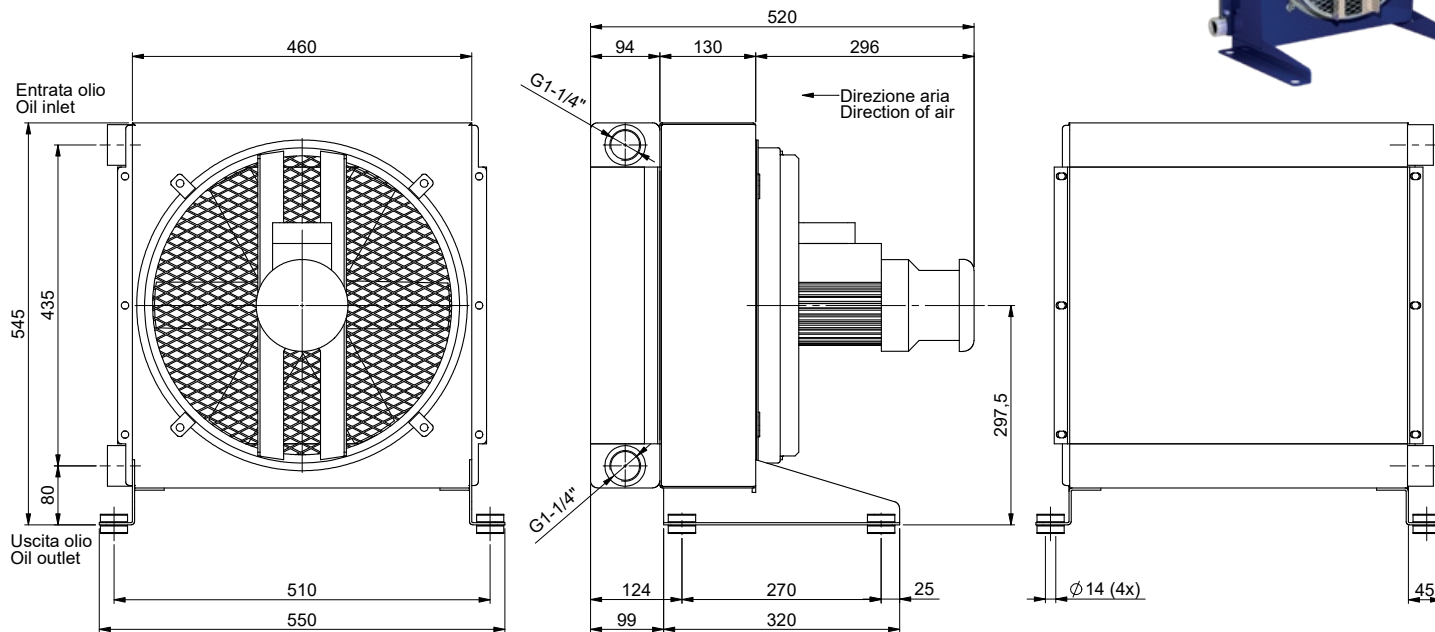

Static working pressure = 20 bar

Test pressure = 35 bar

CODE	OIL FLOW l/min	CAP. l	VOLT. V	FREQ. Hz	POWER W	CURRENT A	AIR FLOW m ³ /h	PROT. IP	NOISE LEV. dB(A)	WEIGHT kg	ø FAN mm	TEMP. °C
3RAP494EMX50	30-240	8	220-240(Δ) / 380-415	50	180	0,67	3300	56	80	50	400	-20/+40
3RAP494EMX60	30-240	8	460 (Y)	60	180	0,59	3500	56	82	30	400	-20/+40

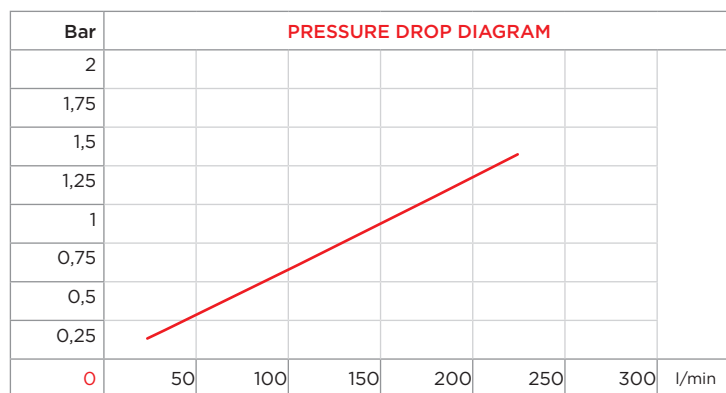
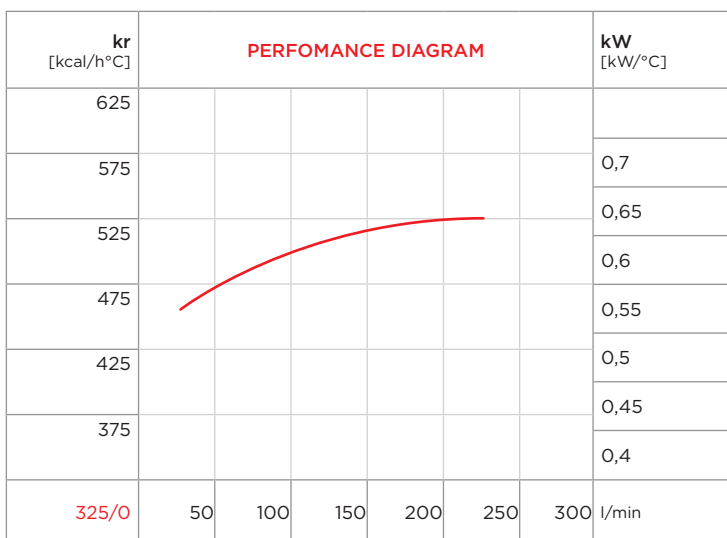

CORRECTION FACTOR							
cSt	22	30	46	68	100	150	220
f	0,6	1	1,5	2,3	3,5	5	7

PURCHASE CODES

AP 494 EMX three-phase 380-415V 50Hz	3RAP494EMX50
AP 494 EMX three-phase 460V 60HZ	3RAP494EMX60

SPARE PARTS

Cooling element	3RNL494A
Frame	3CNAP494EMX.1
Electric fan 380-415V 50Hz	1VNAP432EMX50
Electric fan 460V 60Hz	1VNAP432EMX60

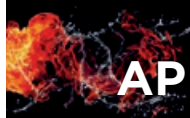

AP 580 EMX

AC MOTOR AIR-OIL HEAT EXCHANGERS
MARINE USE AND ATEX REGULATION EMX TYPE
SCAMBIATORI DI CALORE ARIA OLIO CON VENTILATORE A
CORRENTE ALTERNATA USO MARINO NORME ATEX SERIE EMX



- Dimensions and technical characteristics are not binding

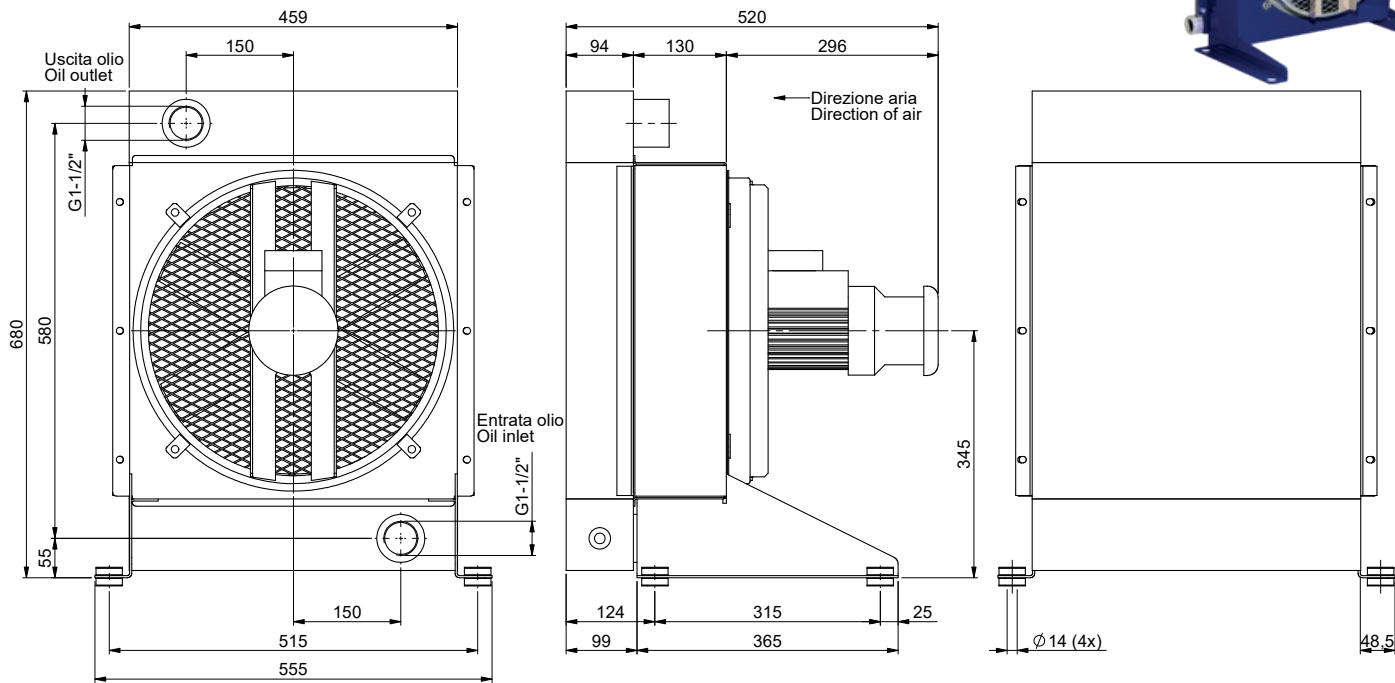

Static working pressure = 20 bar

Test pressure = 35 bar

CODE	OIL FLOW l/min	CAP. l	VOLT. V	FREQ. Hz	POWER W	CURRENT A	AIR FLOW m ³ /h	PROT. IP	NOISE LEV. dB(A)	WEIGHT kg	Ø FAN mm	TEMP. °C
3RAP580EMX50	100-250	11,5	220-240(Δ) / 380-415 (Y)	50	180	0,67	3500	56	79	62	400	-20/+40
3RAP580EMX60	100-250	11,5	460 (Y)	50	180	0,59	3700	56	81	62	400	-20/+40

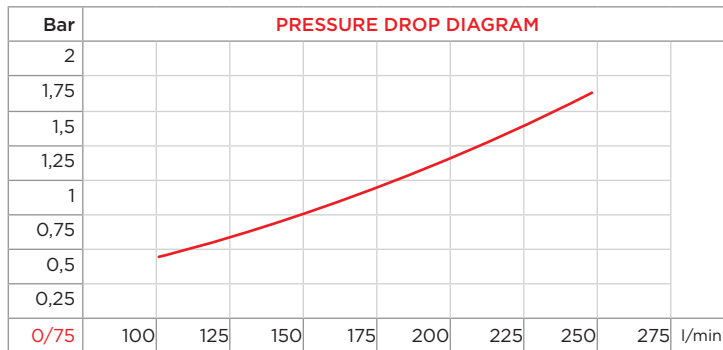
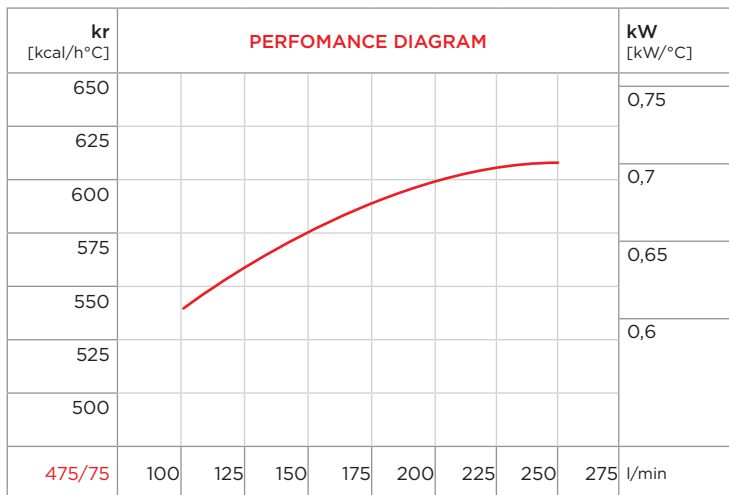

CORRECTION FACTOR

cSt	22	30	46	68	100	150	220
f	0,6	1	1,5	2,3	3,5	5	7

PURCHASE CODES

AP 580 EMX three-phase 380-415V 50Hz	3RAP580EMX50
AP 580 EMX three-phase 460V 60HZ	3RAP580EMX60

SPARE PARTS

Cooling element	3RNL580A
Frame	3CNAP580EMX.1
Electric fan 380-415V 50Hz	1VNAP432EMX50
Electric fan 460V 60Hz	1VNAP432EMX60

AP 680 EMX

AC MOTOR AIR-OIL HEAT EXCHANGERS
MARINE USE AND ATEX REGULATION EMX TYPE
SCAMBIATORI DI CALORE ARIA OLIO CON VENTILATORE A
CORRENTE ALTERNATA USO MARINO NORME ATEX SERIE EMX



- Dimensions and technical characteristics are not binding
- Static working pressure = 20 bar
- Test pressure = 35 bar

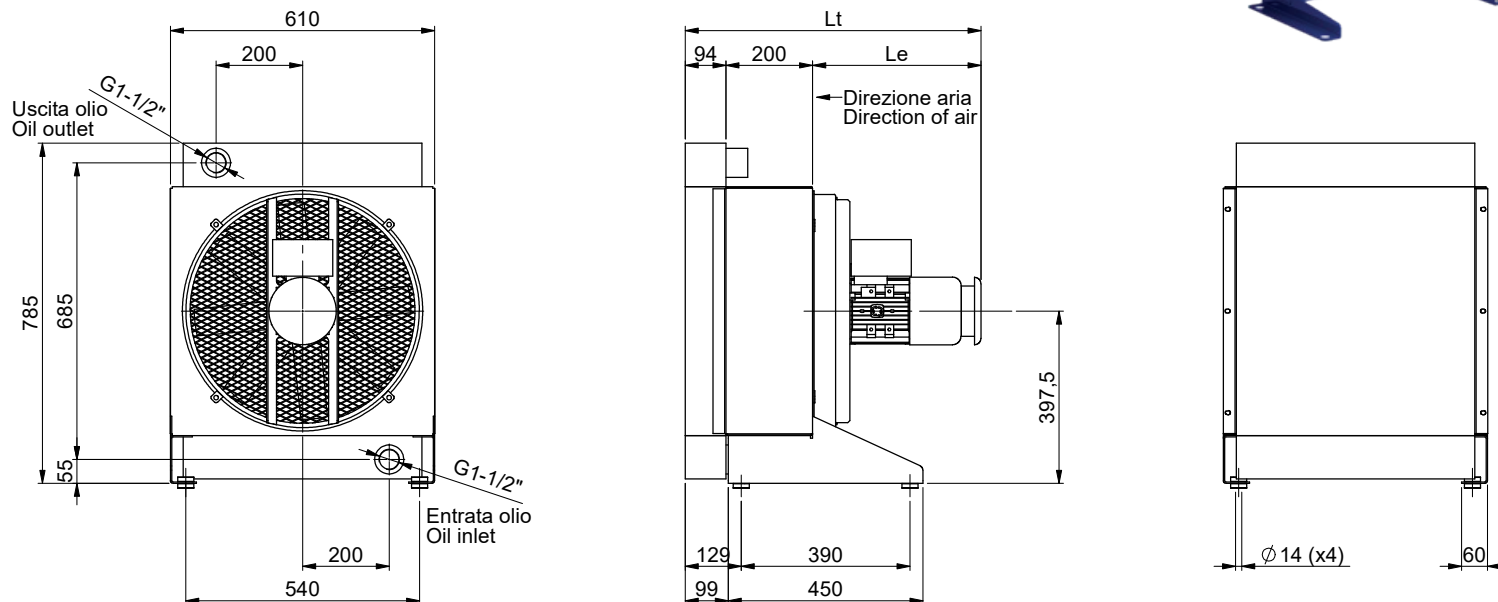

Static working pressure = 20 bar

Test pressure = 35 bar

CODE	OIL FLOW l/min	CAP. l	VOLT. V	FREQ. Hz	POWER W	CURRENT A	AIR FLOW m³/h	PROT. IP	NOISE dB(A)	WEIGHT kg	ø FAN mm	TEMP. °C	DIM. Le Lt	
3RAP680EMX50	100-300	15	220-240(Δ) / 380-415 (Y)	50	550	1,6	7500	56	86	89	500	-20/+40	322	616
3RAP680EMX60	100-300	15	460 (Y)	60	750	1,79	7900	56	86	89	500	-20/+40	364	658

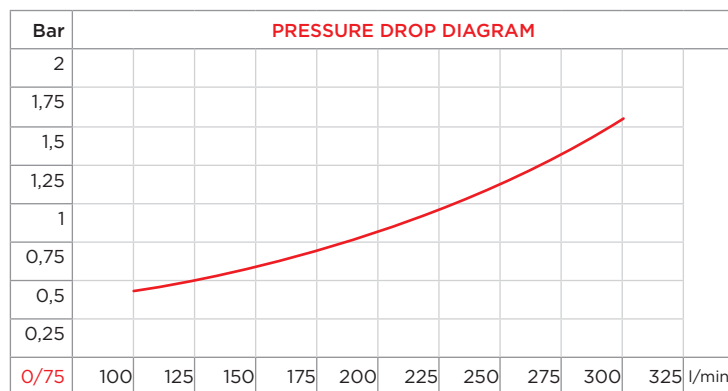
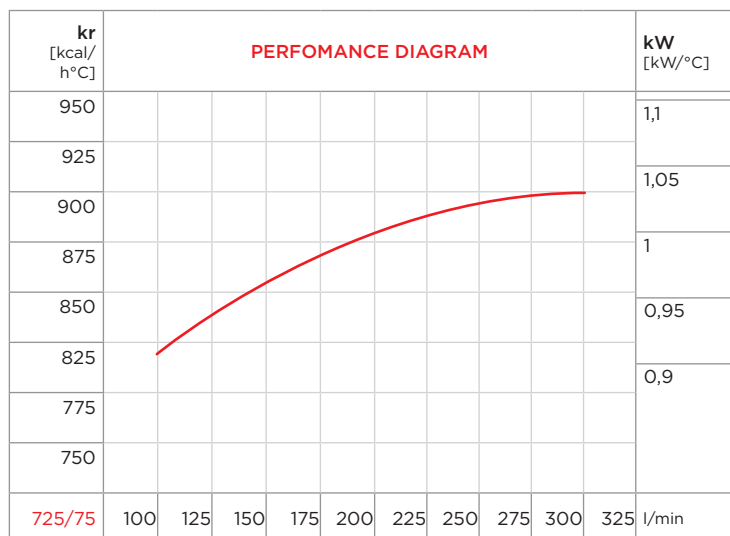

CORRECTION FACTOR

cSt	22	30	46	68	100	150	220
f	0,6	1	1,5	2,3	3,5	5	7

PURCHASE CODES

AP 680 EMX three-phase 380-415V 50Hz	3RAP680EMX50
AP 680 EMX three-phase 460V 60HZ	3RAP680EMX60

SPARE PARTS

Cooling element	3RNL680A
Frame	3CNAP680EMX.1
Electric fan 380-415V 50Hz	1VNAP680EMX50
Electric fan 460V 60Hz	1VNAP680EMX60

AP 730 EMX

AC MOTOR AIR-OIL HEAT EXCHANGERS
MARINE USE AND ATEX REGULATION EMX TYPE
SCAMBIATORI DI CALORE ARIA OLIO CON VENTILATORE A
CORRENTE ALTERNATA USO MARINO NORME ATEX SERIE EMX



- Dimensions and technical characteristics are not binding

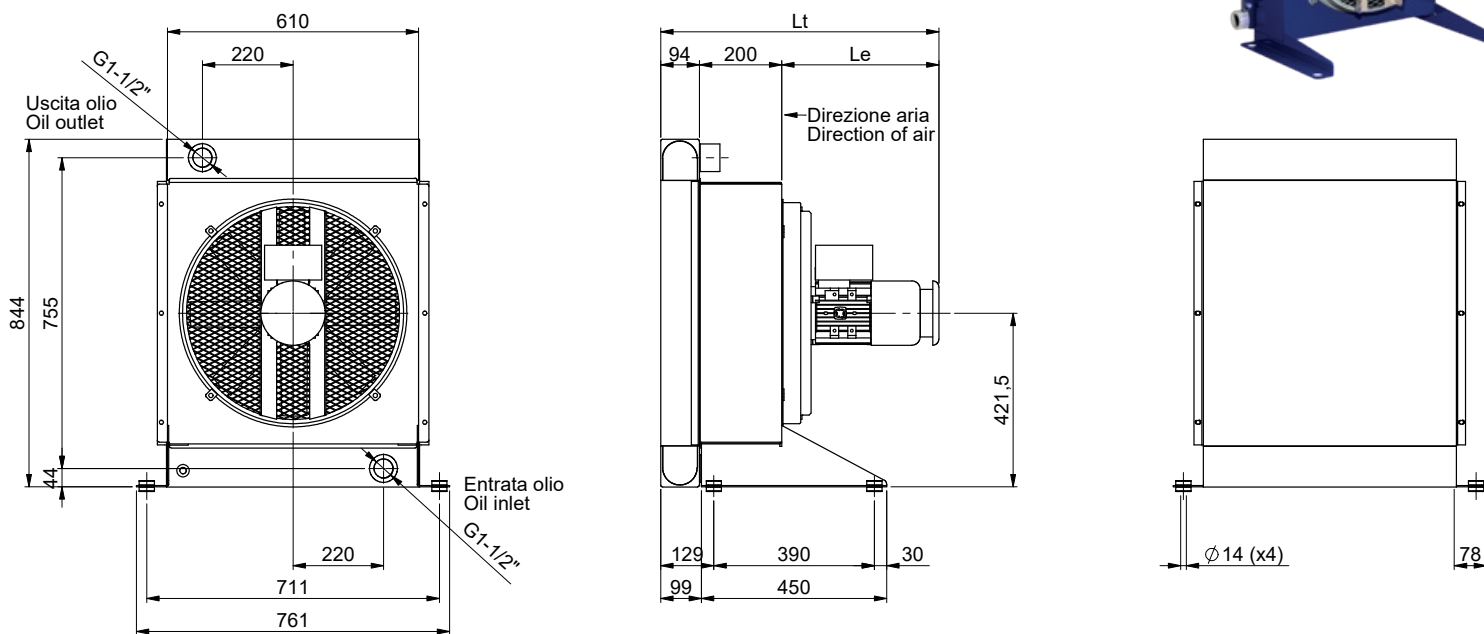

Static working pressure = 20 bar

Test pressure = 35 bar

CODE	OIL FLOW l/min	CAP. l	VOLT. V	FREQ. Hz	POWER W	CURRENT A	AIR FLOW m ³ /h	PROT. IP	NOISE dB(A)	WEIGHT kg	Ø FAN mm	TEMP. °C	DIMENSION Le Lt	
3RAP730EMX50	100-300	16	220-240(Δ) / 380-415 (Y)	50	550	1,6	7800	56	86	98	500	-20/+40	322	616
3RAP730EMX60	100-300	16	460 (Y)	60	750	1,79	8200	56	86	98	500	-20/+40	364	658

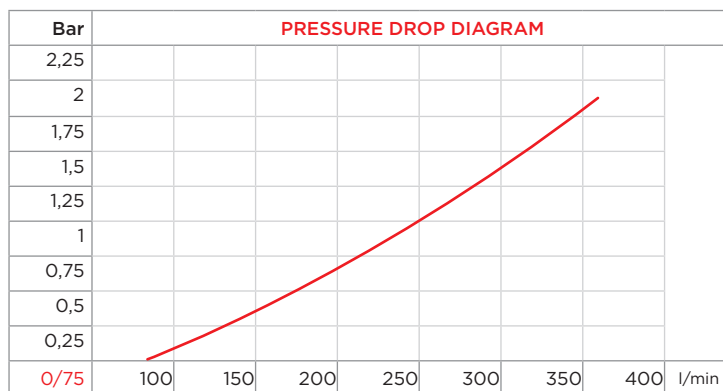
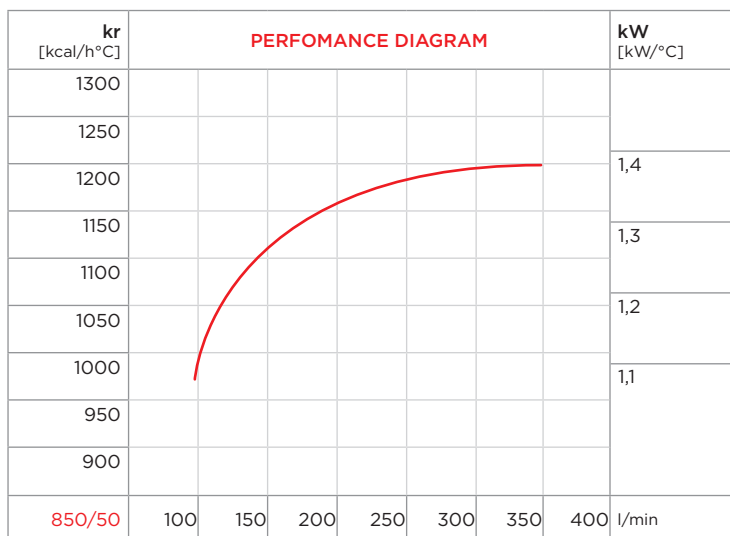

cSt	22	30	46	68	100	150	220
f	0,6	1	1,5	2,3	3,5	5	7

PURCHASE CODES

AP 730 EMX three-phase 380-415V 50Hz	3RAP730EMX50
AP 730 EMX three-phase 460V 60HZ	3RAP730EMX60

SPARE PARTS

Cooling element	3RNL730A
Frame	3CNAP730EMX.1
Electric fan 380-415V 50Hz	1VNAP680EMX50
Electric fan 460V 60Hz	1VNAP680EMX60

AP 830 EMX

AC MOTOR AIR-OIL HEAT EXCHANGERS
MARINE USE AND ATEX REGULATION EMX TYPE
SCAMBIATORI DI CALORE ARIA OLIO CON VENTILATORE A
CORRENTE ALTERNATA USO MARINO NORME ATEX SERIE EMX



- Dimensions and technical characteristics are not binding

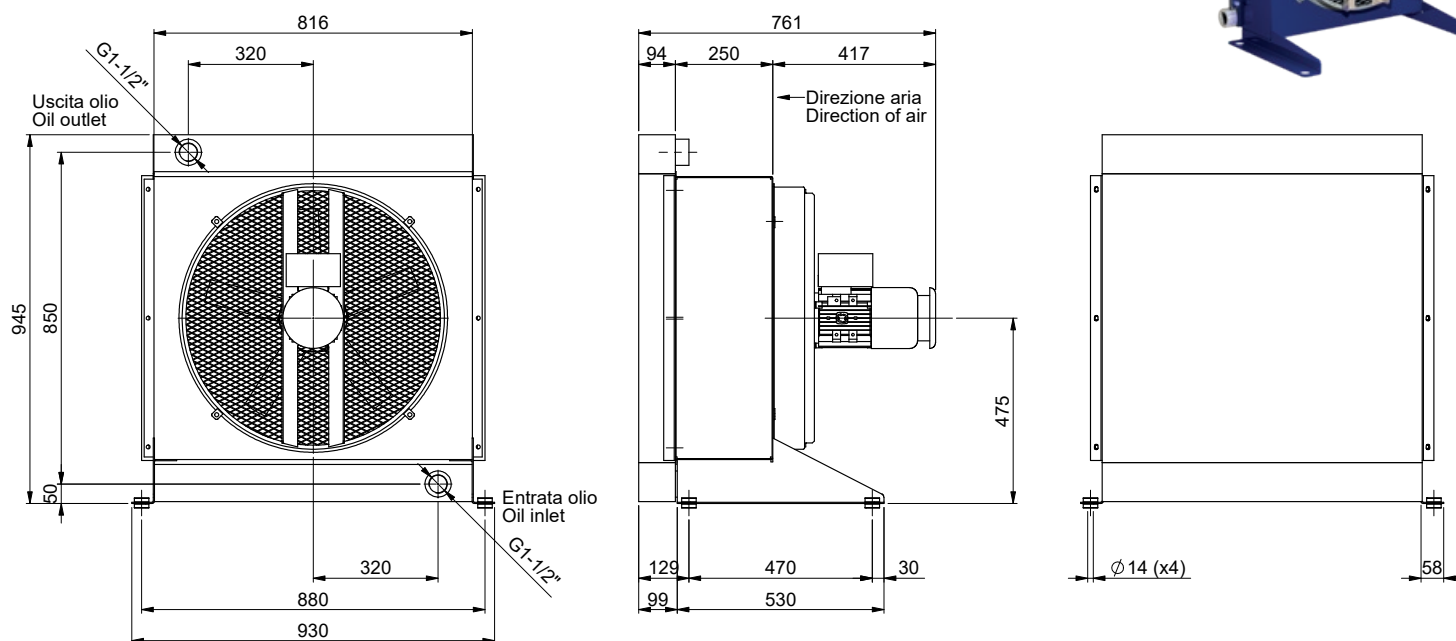

Static working pressure = 20 bar

Test pressure = 35 bar

CODE	OIL FLOW	CAP.	VOLT.	FREQ.	POWER	CURRENT	AIR FLOW	PROT.	NOISE LEV.	WEIGHT	ø FAN	TEMP.
	l/min	l	V	Hz	W	A	m ³ /h	IP	dB(A)	kg	mm	°C
3RAP830EMX50	150-400	20	220-240(Δ) / 380-415 (Y)	50	1100	2,58	10000	56	87	115	560	-20/+40
3RAP830EMX60	150-400	20	460 (Y)	60	1100	2,24	10600	56	87	115	560	-20/+40

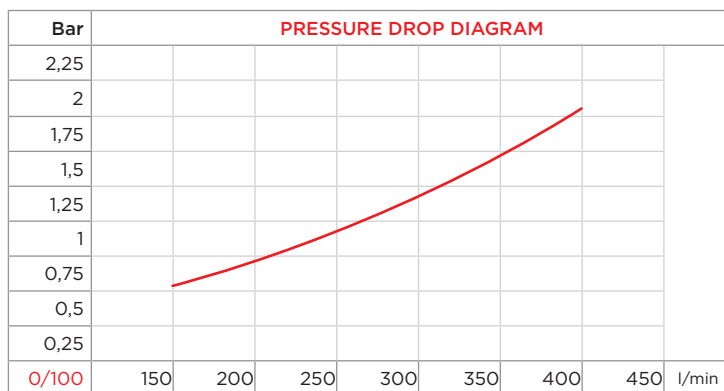
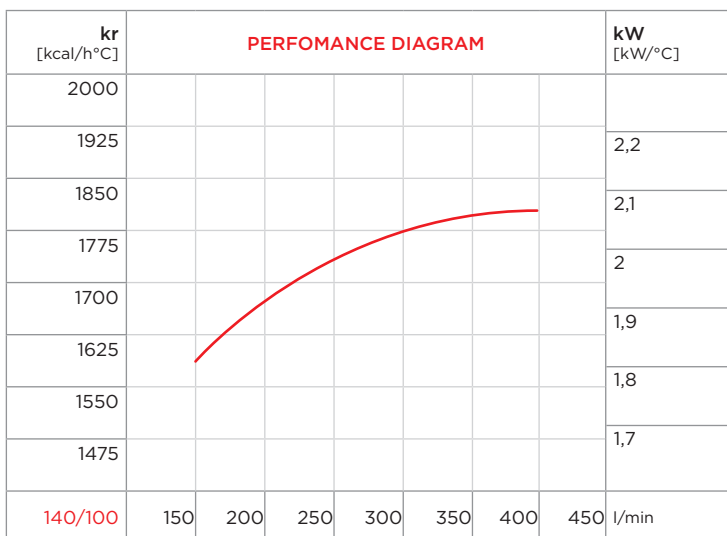

	22	30	46	68	100	150	220
cSt	0,6	1	1,5	2,3	3,5	5	7

PURCHASE CODES

AP 830 EMX three-phase 380-415V 50Hz	3RAP830EMX50
AP 830 EMX three-phase 460V 60HZ	3RAP830EMX60

SPARE PARTS

Cooling element	3RNL830A
Frame	3CNAP830EMX.1
Electric fan 380-415V 50Hz	1VNAP830EMX50
Electric fan 460V 60Hz	1VNAP830EMX60

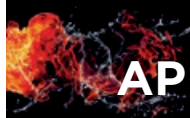

AP 2/680 EMX

AC MOTOR AIR-OIL HEAT EXCHANGERS
MARINE USE AND ATEX REGULATION EMX TYPE
SCAMBIATORI DI CALORE ARIA OLIO CON VENTILATORE A
CORRENTE ALTERNATA USO MARINO NORME ATEX SERIE EMX



- Dimensions and technical characteristics are not binding

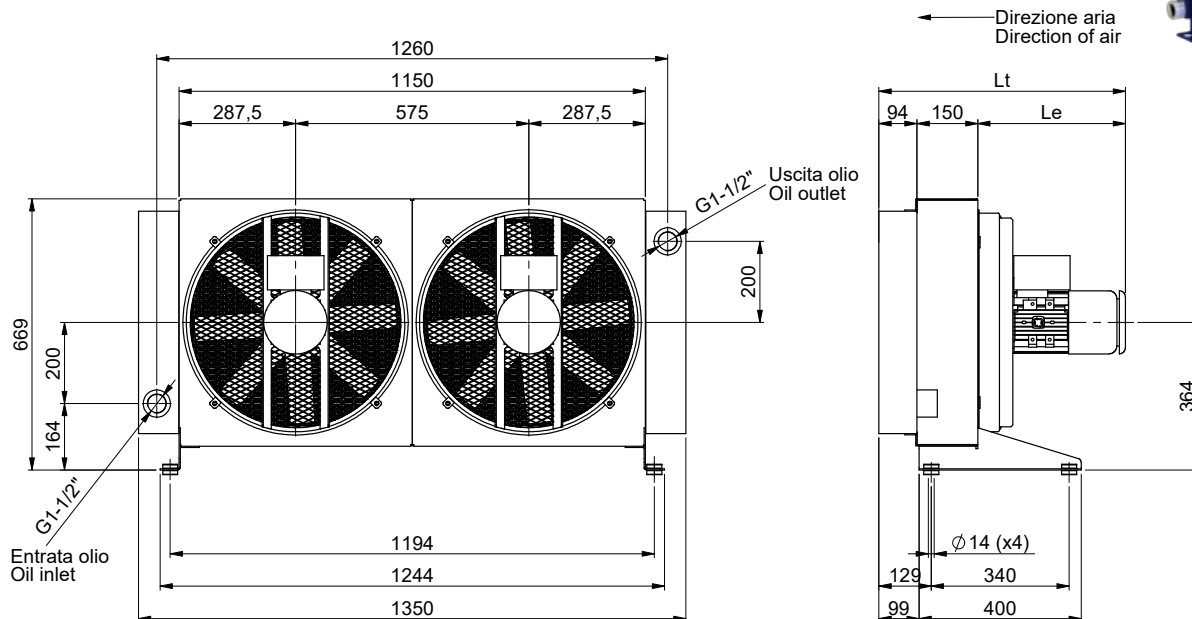

Static working pressure = 20 bar

Test pressure = 35 bar

CODE	OIL FLOW l/min	CAP. l	VOLT. V	FREQ. Hz	POWER W	CURRENT A	AIR FLOW m ³ /h	PROT. IP	NOISE dB(A)	WEIGHT kg	ϕ FAN mm	TEMP. °C	DIMENSION	
													Le	Lt
3RAP2/680EMX50	100-300	28	220-240(Δ) / 380-415 (Y)	50	2x 550	2x 1,6	2x 7500	56	87	185	500	-20/+40	322	566
3RAP2/680EMX60	100-300	28	460 (Y)	60	2x 750	2x 1,79	2x 7900	56	87	185	500	-20/+40	364	608

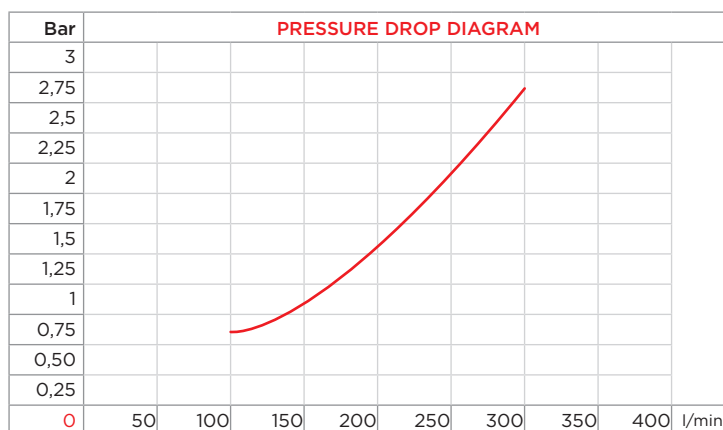
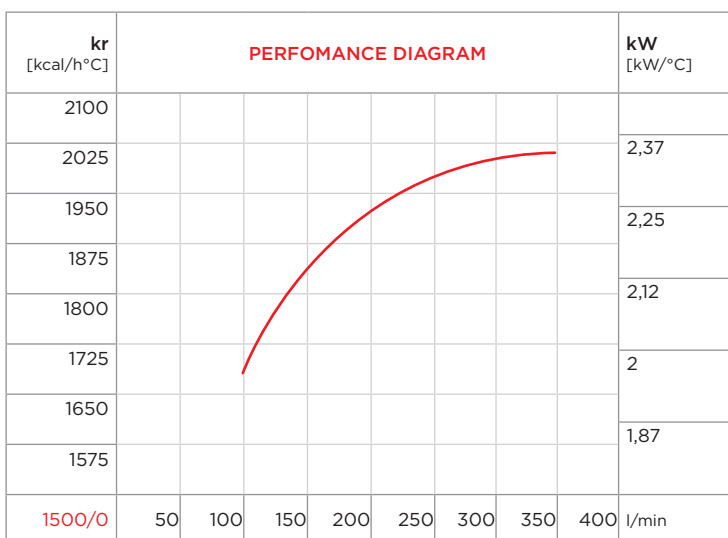

CORRECTION FACTOR							
cSt	22	30	46	68	100	150	220
f	0,6	1	1,5	2,3	3,5	5	7

PURCHASE CODES

AP 2/680 EMX three-phase 380-415V 50Hz	3RAP2/680EMX50
AP 2/680 EMX three-phase 460V 60HZ	3RAP2/680EMX60

SPARE PARTS

Cooling element	3RNL2/680A
Frame	3CNAP2/680EMX.1
Electric fan 380-415V 50Hz	1VNAP680EMX50
Electric fan 460V 60Hz	1VNAP680EMX60

AP 2/730 EMX

AC MOTOR AIR-OIL HEAT EXCHANGERS
MARINE USE AND ATEX REGULATION EMX TYPE
SCAMBIATORI DI CALORE ARIA OLIO CON VENTILATORE A
CORRENTE ALTERNATA USO MARINO NORME ATEX SERIE EMX



- Dimensions and technical characteristics are not binding

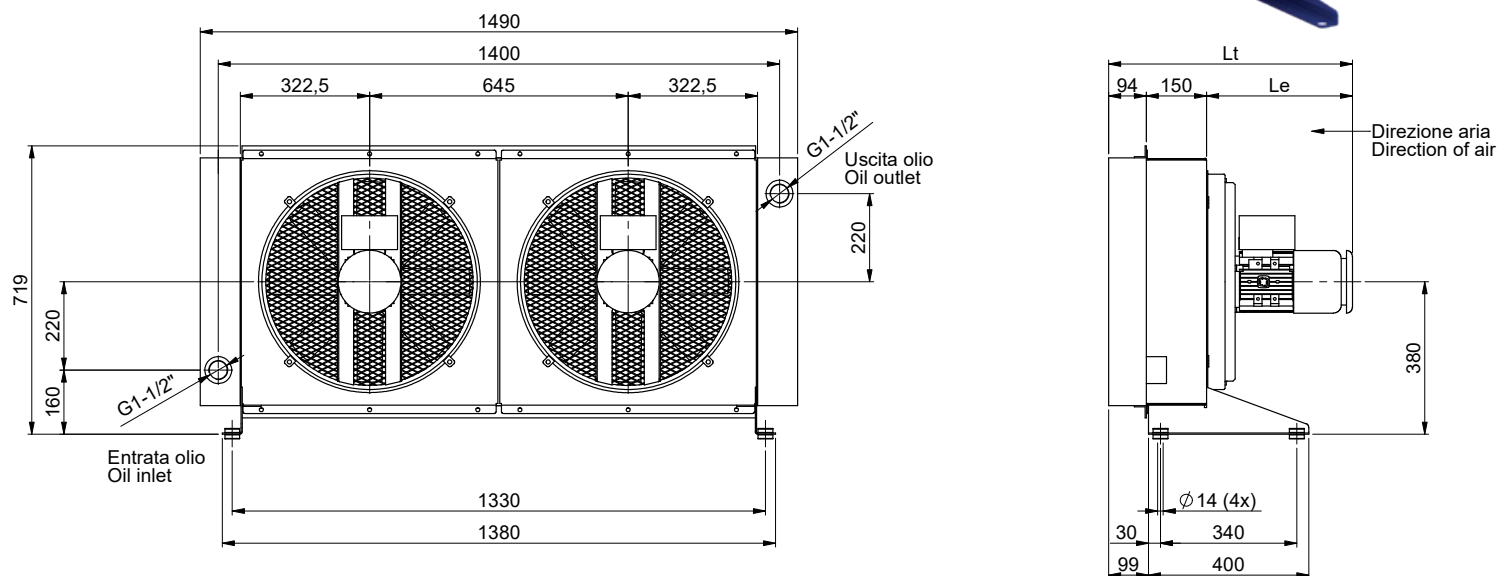

Static working pressure = 20 bar

Test pressure = 35 bar

CODE	OIL FLOW l/min	CAP. l	VOLT. V	FREQ. Hz	POWER W	CURRENT A	AIR FLOW m ³ /h	PROT. IP	NOISE dB(A)	WEIGHT kg	ø FAN mm	TEMP. °C	DIMENSION Le Lt	
	100-350	30	220-240(Δ) / 380-415	50	2x 550	2x 1,6	2x 7800	56	87	193	500	-20/+40	322	566
	100-350	30	460 (Y)	60	2x 750	2x 1,79	2x 8200	56	88	193	500	-20/+40	364	608

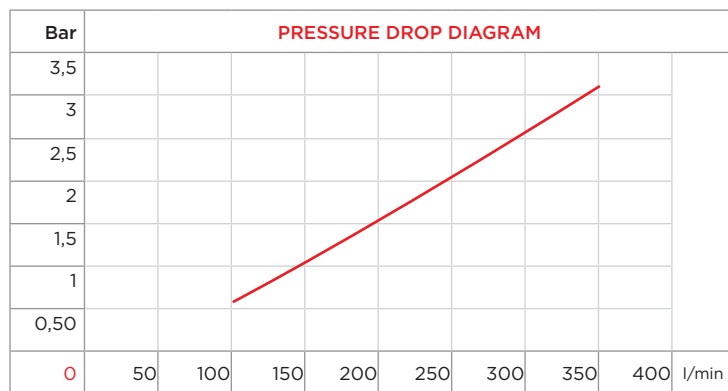
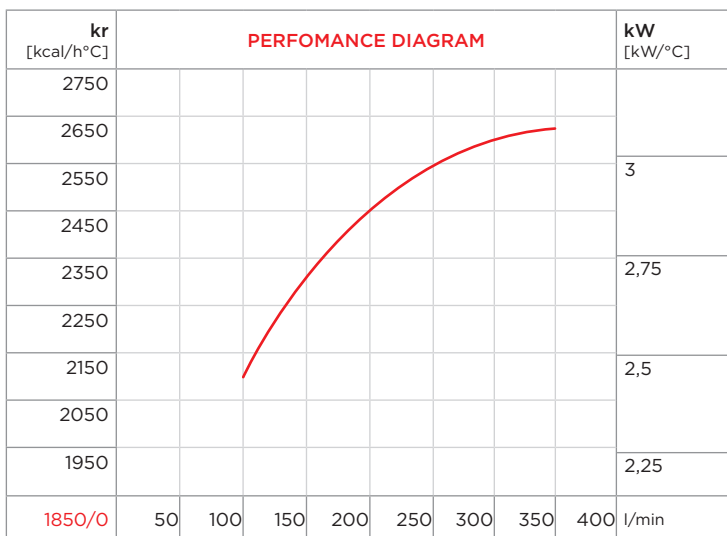

CORRECTION FACTOR							
cSt	22	30	46	68	100	150	220
f	0,6	1	1,5	2,3	3,5	5	7

PURCHASE CODES

AP 2/730 EMX three-phase 380-415V 50Hz	3RAP2/730EMX50
AP 2/730 EMX three-phase 460V 60HZ	3RAP2/730EMX60

SPARE PARTS

Cooling element	3RNL2/730A
Frame	3CNAP2/730EMX.1
Electric fan 380-415V 50Hz	1VNAP680EMX50
Electric fan 460V 60Hz	1VNAP680EMX60

AP 2/830 EMX

AC MOTOR AIR-OIL HEAT EXCHANGERS
MARINE USE AND ATEX REGULATION EMX TYPE
SCAMBIATORI DI CALORE ARIA OLIO CON VENTILATORE A
CORRENTE ALTERNATA USO MARINO NORME ATEX SERIE EMX



- Dimensions and technical characteristics are not binding
- Static working pressure = 20 bar
- Test pressure = 35 bar

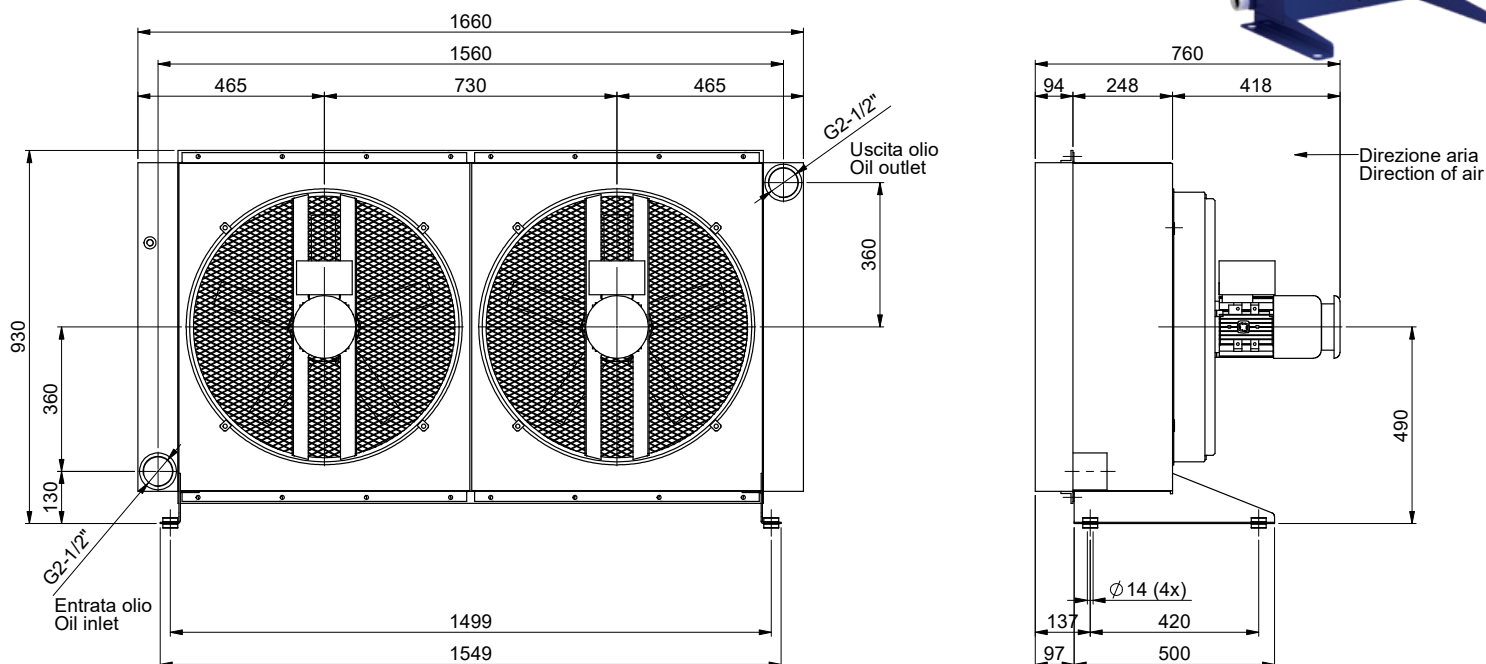

Static working pressure = 20 bar

Test pressure = 35 bar

CODE	OIL FLOW l/min	CAP. l	VOLT. V	FREQ. Hz	POWER W	CURRENT A	AIR FLOW m³/h	PROT. IP	NOISE LEV. dB(A)	WEIGHT kg	Ø FAN mm	TEMP. °C
	150-400	40	220-240(Δ) / 380-415	50	2x 550	2x 1,6	2x 7800	56	89	193	500	-20/+40
	150-400	40	460 (Y)	60	2x 750	2x 1,79	2x 8200	56	89	193	500	-20/+40

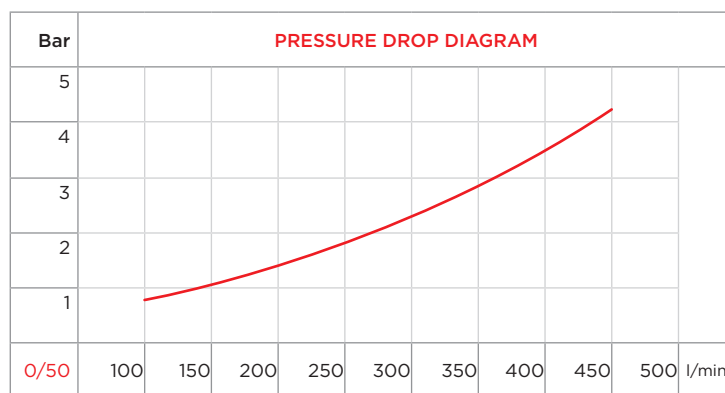
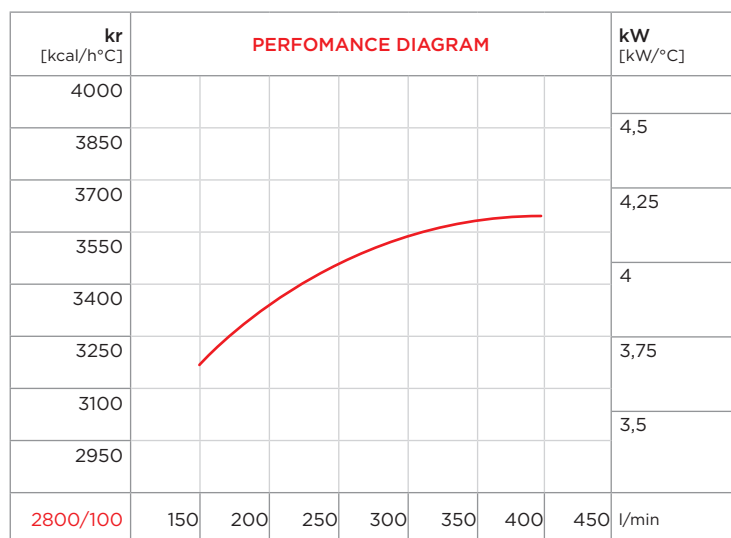

CORRECTION FACTOR

cSt	22	30	46	68	100	150	220
f	0,6	1	1,5	2,3	3,5	5	7

PURCHASE CODES

AP 2/830 EMX three-phase 380-415V 50Hz	3RAP2/830EMX50
AP 2/830 EMX three-phase 460V 60HZ	3RAP2/830EMX60

SPARE PARTS

Cooling element	3RNL2/830A
Frame	3CNAP2/830EMX.1
Electric fan 380-415V 50Hz	1VNAP830EMX50
Electric fan 460V 60Hz	1VNAP830EMX60

AP 3/830 EMX

AC MOTOR AIR-OIL HEAT EXCHANGERS
MARINE USE AND ATEX REGULATION EMX TYPE
SCAMBIATORI DI CALORE ARIA OLIO CON VENTILATORE A
CORRENTE ALTERNATA USO MARINO NORME ATEX SERIE EMX



- Dimensions and technical characteristics are not binding
- Static working pressure = 20 bar
- Test pressure = 35 bar

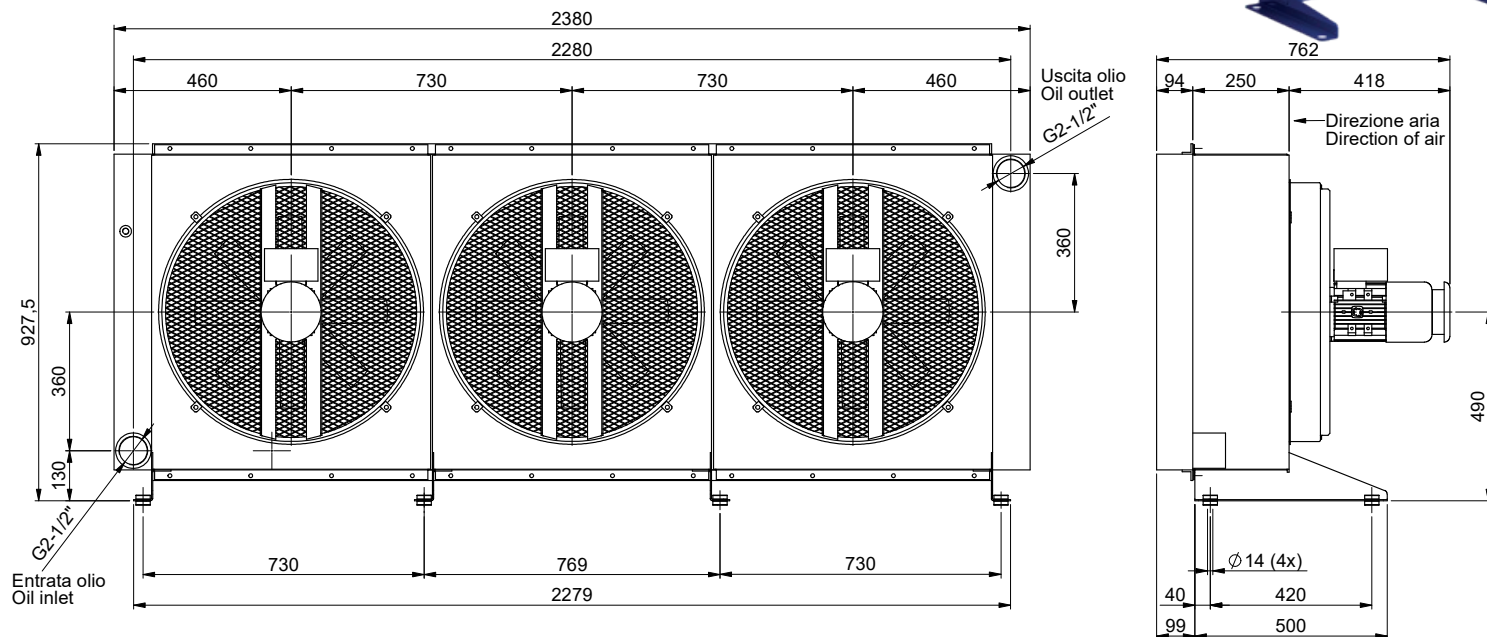

Static working pressure = 20 bar

Test pressure = 35 bar

CODE	OIL FLOW l/min	CAP. l	VOLT. V	FREQ. Hz	POWER W	CURRENT A	AIR FLOW m ³ /h	PROT. IP	NOISE LEV. dB(A)	WEIGHT kg	ø FAN mm	TEMP. °C
3RAP3/830EMX50	150-400	60	220-240(Δ) / 380-415	50	3x 1100	3x 2,58	2x 10000	56	90	360	560	-20/+40
	150-400	60	460 (Y)	60	3x 1100	3x 2,24	2x 10600	56	91	360	560	-20/+40

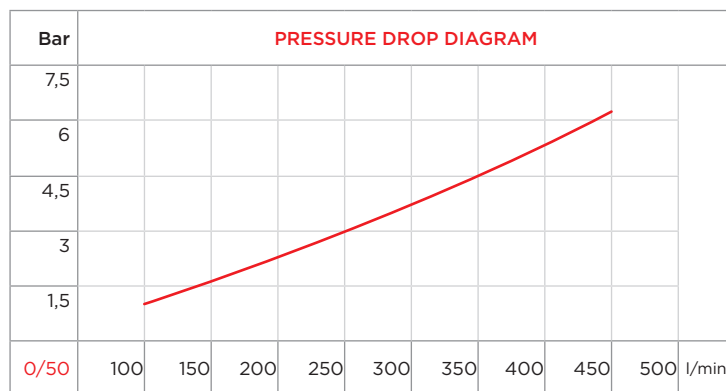
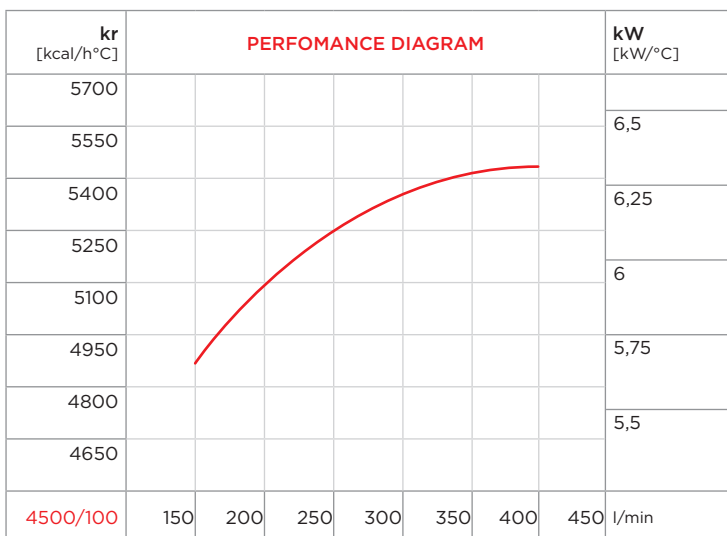

CORRECTION FACTOR							
cSt	22	30	46	68	100	150	220
f	0,6	1	1,5	2,3	3,5	5	7

PURCHASE CODES

AP 3/830 EMX three-phase 380-415V 50Hz	3RAP3/830EMX50
AP 3/830 EMX three-phase 460V 60HZ	3RAP3/830EMX60

SPARE PARTS

Cooling element	3RNL3/830A
Frame	3CNAP3/830EMX.1
Electric fan 380-415V 50Hz	1VNAP830EMX50
Electric fan 460V 60Hz	1VNAP830EMX60

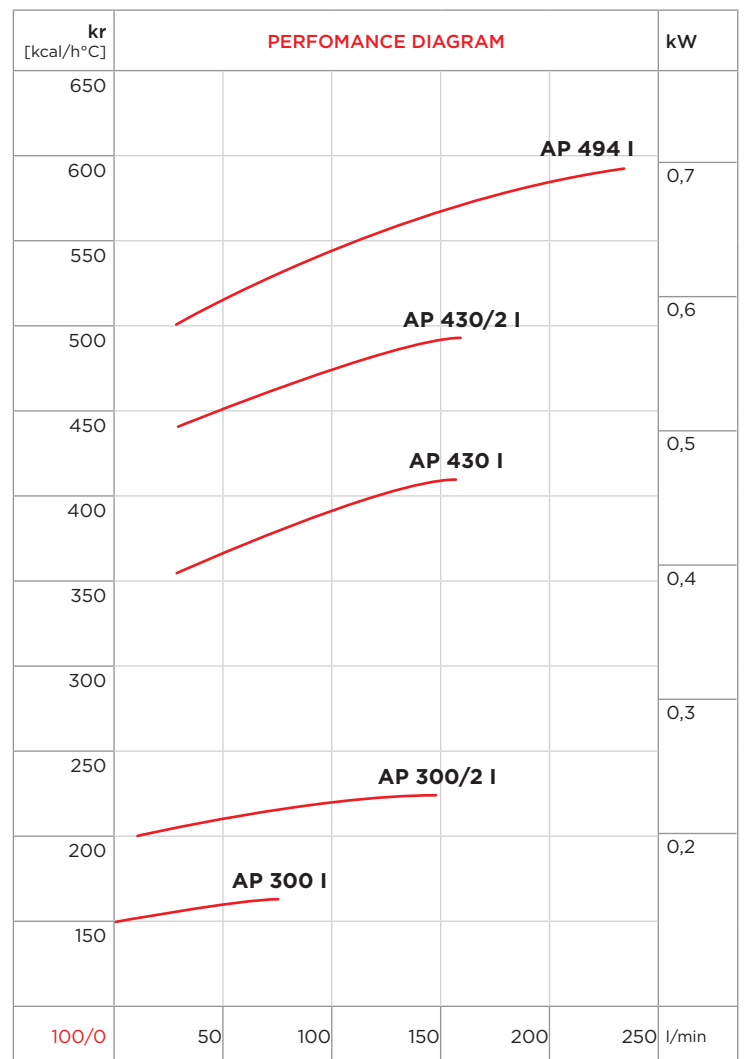
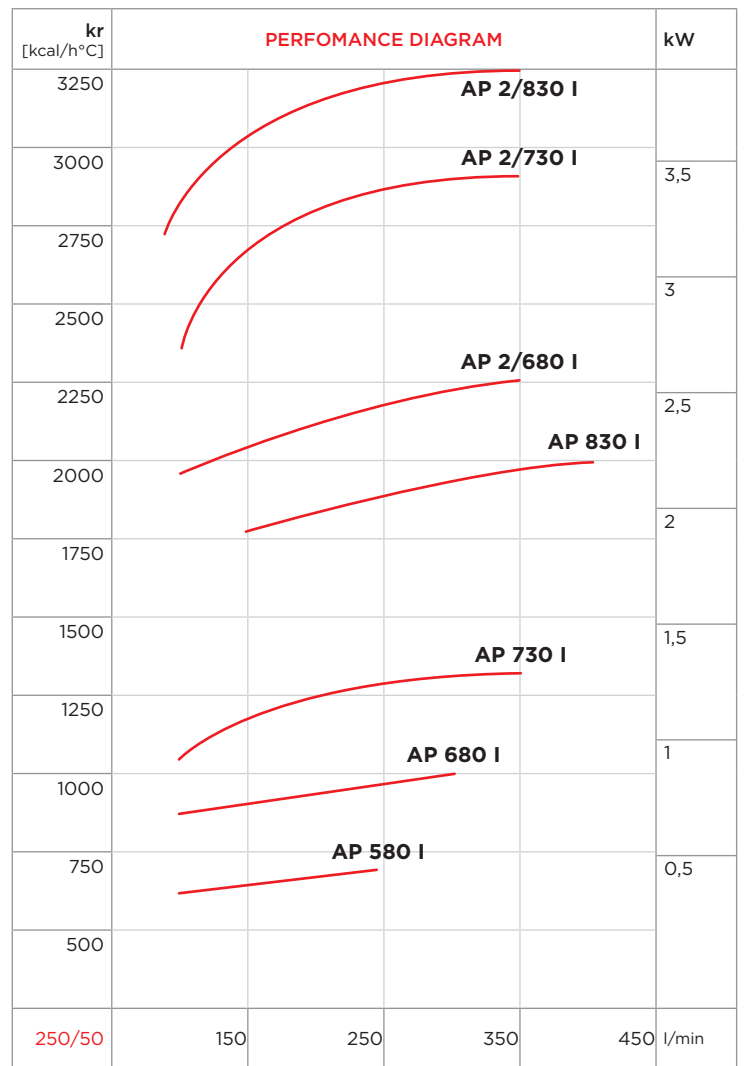

AIR-OIL HEAT EXCHANGERS WITH IDRAULIC MOTOR

SCAMBIATORI DI CALORI ARIA-OLIO CON VENTOLA AZIONATA DA MOTORE IDRAULICO



These kind of exchangers have been designed for a use on mobile machines when the battery cannot supply enough electric energy to the motor of the DC fan or when the DC exchanger is not able to produce high thermic exchanges.

The particular structure of the cooling element allows great thermic performances and pressure resistance. **Maximum working static pressure: 20 bar.**

Our technical Department is available to suggest and find the better solution in case of particular working conditions, pressures, frequencies, vibrations, etc.

It is always recommended to assemble in parallel with the exchanger a by-pass valve to avoid extreme counter-pressures, particularly when the machine is started with cold oil. On the contrary, it is not useful to use a check valve as by-pass to protect the exchanger from pressure's peaks, since the inertia of the valve itself is too high in comparison with the speed of the pressure waves that occur into the oleo hydraulic systems.

The flow rates shown in the tables are the ones recommended for the exchanger proper working.

The efficiency curves show the specific exchange capacity in kcal/h°C or in kW/h°C according to the different oil rates. To calculate the heat quantity the different exchangers are able to dissipate it is enough to multiply such capacity by the difference between the requested oil temperature and the summer room temperature.

We pay particular attention to the choice of our components in order to supply the customer with a reliable product.

The fans are metallic, and metallic are the protection grills used also to fix the hydraulic motor. Upon request, it is possible to receive the motor support, which helps the driving shaft absorbing radial stresses. Upon request, it is also possible to receive a thermo switch with IP 65 protection degree and different temperature ranges, 47°C or 60°C.

For the right calculation of air-oil heat exchangers, we supply our customers with a calculation program.

The air-oil heat exchangers can be used to cool other kind of fluids, which must be compatible with aluminum and its alloys.

However, for each use, with the exception of oil cooling, we recommend to consult our Technical Department.

Questi tipi di scambiatori sono stati progettati per essere utilizzati su macchine mobili quando la batteria della stessa non può fornire l'energia elettrica necessaria al motore a corrente continua del ventilatore, oppure quando la necessità di ottenere scambi termici elevati non può essere soddisfatta dagli scambiatori a corrente continua.

*La particolare costruzione del radiatore consente di ottenere notevoli rese termiche e forte resistenza alla pressione; **pressione massima statica di funzionamento: 20 bar.***

Il nostro Ufficio Tecnico è a disposizione per valutare la soluzione più opportuna in presenza di particolari condizioni di lavoro, pressioni, frequenze, vibrazioni, ecc..

È sempre consigliabile montare in parallelo allo scambiatore una valvola di by-pass per evitare eccessive contropressioni soprattutto al momento dell'avviamento della macchina con olio freddo. Non è invece conveniente utilizzare una valvola di ritegno come by-pass per proteggere lo scambiatore dai picchi di pressione in quanto l'inerzia della valvola stessa è troppo alta rispetto alla velocità delle onde di pressione che si sviluppano all'interno dell'olio degli impianti oleoidraulici.

Le portate olio indicate nelle tabelle sono quelle consigliate per il buon funzionamento dello scambiatore.

Le curve di rendimento forniscono la potenzialità di scambio specifica in kcal/h°C o in kW/h°C in funzione della portata olio; per calcolare la quantità di calore che i vari scambiatori sono in grado di disperdere, è sufficiente moltiplicare tale potenzialità per la differenza tra le temperature dell'olio desiderata e dell'aria ambiente massima estiva. Particolare attenzione è stata posta nella scelta dei componenti per fornire alla clientela un prodotto estremamente affidabile. Le ventole sono in metallo, così come le reti di protezione che fungono anche da fissaggio del motore idraulico. A richiesta può essere fornito il supporto motore, per assorbire sollecitazioni radiali sull'albero del motore; sempre a richiesta possiamo fornire un termostato avente protezione IP65 con tarature a 47 o 60°C a scelta.

Per il calcolo degli scambiatori aria-olio è disponibile un programma.

Gli scambiatori aria-olio possono essere utilizzati per raffreddare altri tipi di fluidi, a condizione che essi siano compatibili con l'alluminio e le sue leghe.

Consigliamo comunque, per qualsiasi impiego che non sia il raffreddamento dell'olio, di contattare il nostro Ufficio Tecnico.

AP 300 I

AIR-OIL HEAT EXCHANGERS WITH IDRAULIC MOTOR
SCAMBIATORI ARIA-OLIO CON MOTORE IDRAULICO



- Dimensions and technical characteristics are not binding

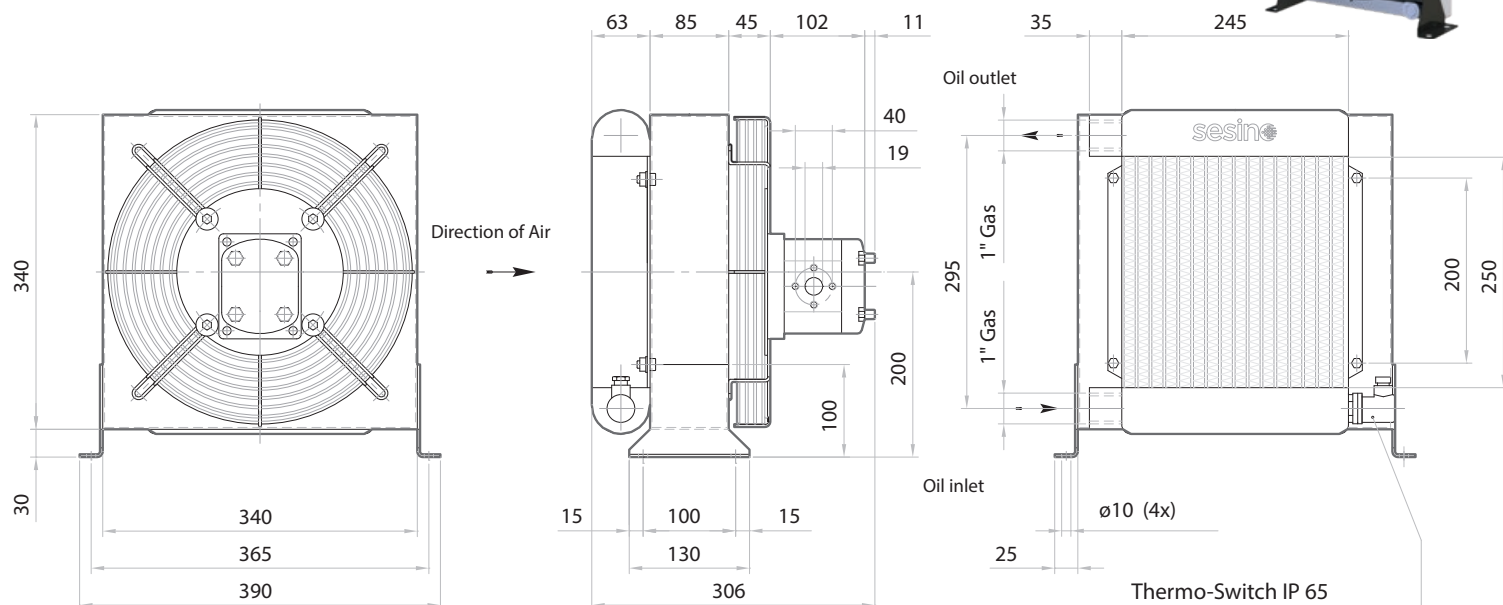

Static working pressure = 20 bar

Test pressure = 35 bar

OIL FLOW	FAN SPEED	POWER	DISPLACEMENT	MOTOR FLOW	AIR FLOW	NOISE LEVEL	WEIGHT	CAPACITY	Ø FAN
l/min	rpm	W	cc/r	l/min	m ³ /h	dB(A)	kg	lt.	mm
10-80	2300	200	11,3	26	2.000	68	14	2	255

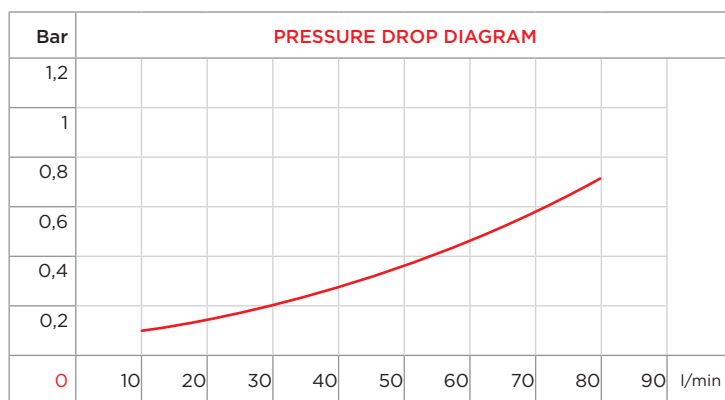
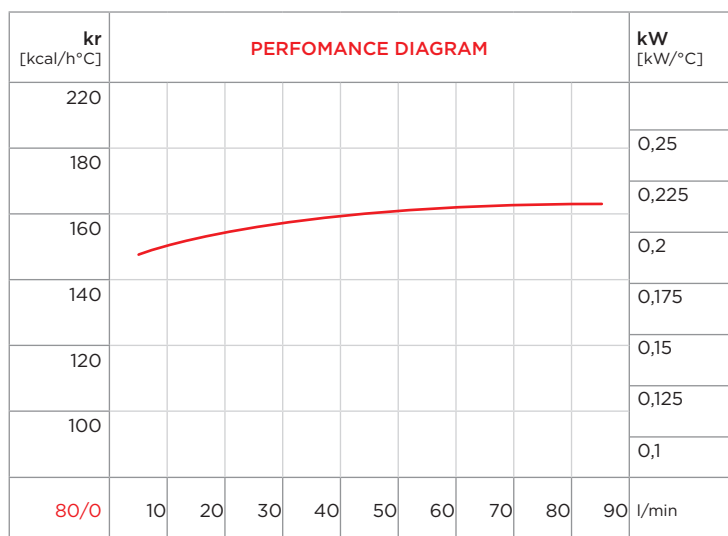

CORRECTION FACTOR

cSt	22	30	46	68	100	150	220
f	0,6	1	1,5	2,3	3,5	5	7

PURCHASE CODES

AP 300 I With hydraulic motor	3RAP300IA
AP 300 I Prepared	3RAP300I4A

SPARE PARTS

Cooling element	3RNL300
Housing	1300TLV
Frame	3CNAP300I.1
Fan	1G2806230PAV
Fan Grill	1RTAP300I
Hydraulic motor	1MO2/M16
Thermo-switch 60-49 IP 65	1TRM60-49
Thermo-switch 47-36 IP 65	1TRM47-36

AP 300/2 I

AIR-OIL HEAT EXCHANGERS WITH IDRAULIC MOTOR
SCAMBIATORI ARIA-OLIO CON MOTORE IDRAULICO



- Dimensions and technical characteristics are not binding

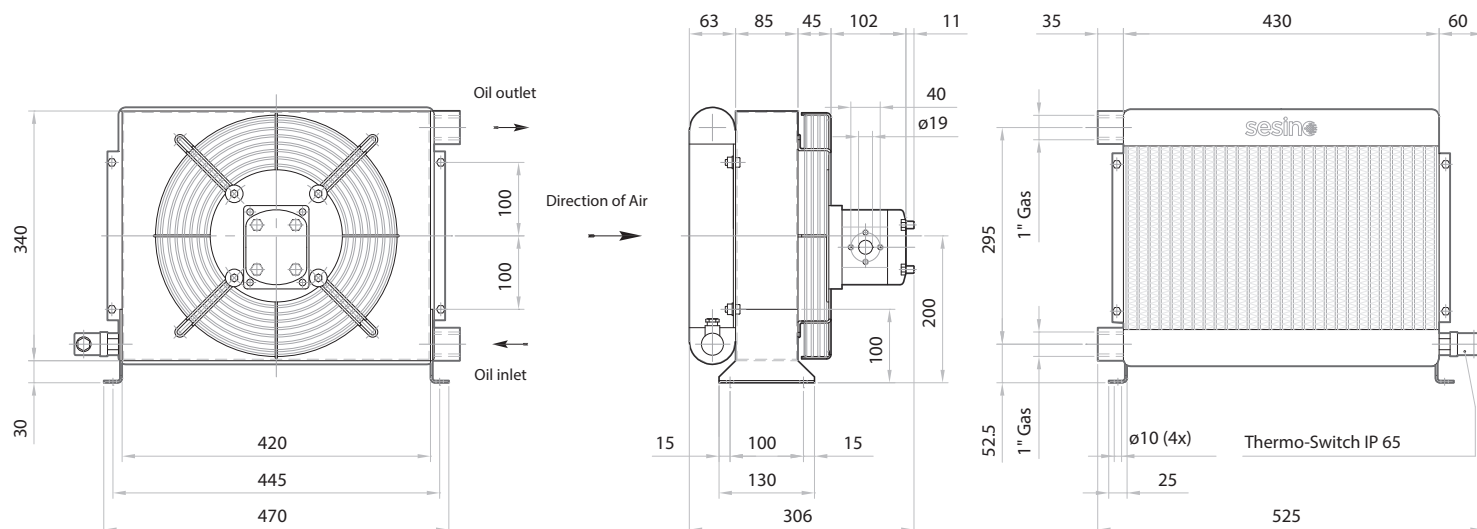

Static working pressure = 20 bar

Test pressure = 35 bar

OIL FLOW	FAN SPEED	POWER	DISPLACEMENT	MOTOR FLOW	AIR FLOW	NOISE LEVEL	WEIGHT	CAPACITY	Ø FAN
l/min	rpm	W	cc/r	l/min	m ³ /h	dB(A)	kg	lt.	mm
20-150	2300	200	11,3	26	2.500	70	19	3,6	255

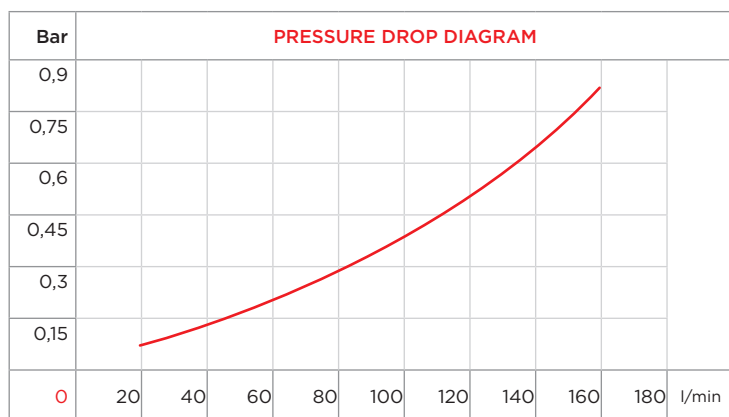
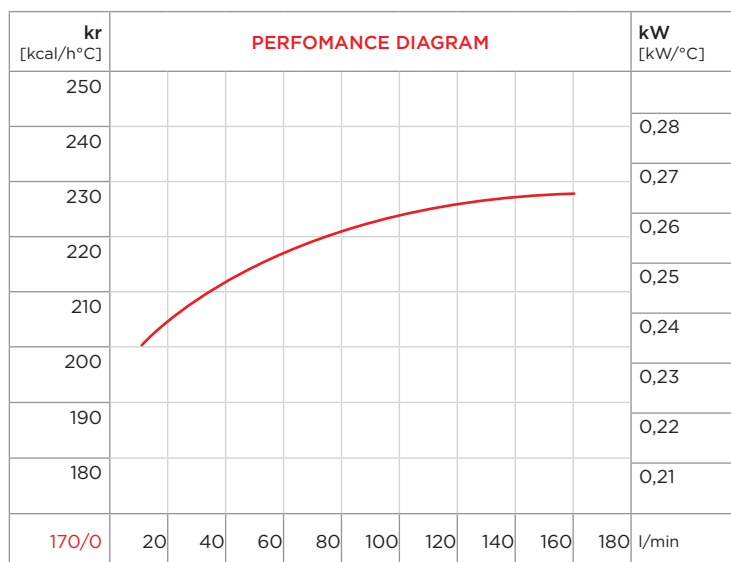

CORRECTION FACTOR

cSt	22	30	46	68	100	150	220
f	0,6	1	1,5	2,3	3,5	5	7

PURCHASE CODES

AP 300/2 I With hydraulic motor	3RAP302IA
AP 300/2 I Prepared	3RAP302I4A

SPARE PARTS

Cooling element	3RNL302
Housing	1302TLV
Frame	3CNAP302I.1
Fan	1G2806230PAV
Fan Grill	1RTAP300I
Hydraulic motor	1MO2/M16
Thermo-switch 60-49 IP 65	1TRM60-49
Thermo-switch 47-36 IP 65	1TRM47-36

AP 430 I

AIR-OIL HEAT EXCHANGERS WITH IDRAULIC MOTOR
SCAMBIATORI ARIA-OLIO CON MOTORE IDRAULICO



- Dimensions and technical characteristics are not binding

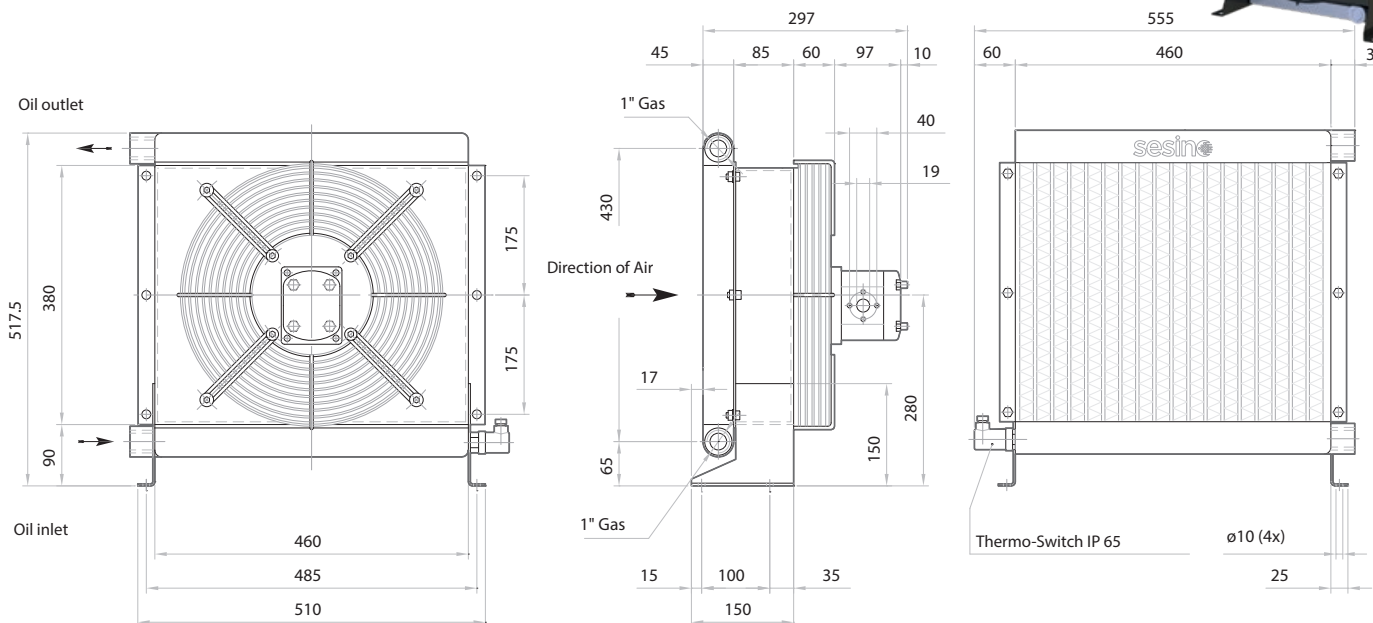

Static working pressure = 20 bar

Test pressure = 35 bar

OIL FLOW	FAN SPEED	POWER	DISPLACEMENT	MOTOR FLOW	AIR FLOW	NOISE LEVEL	WEIGHT	CAPACITY	Ø FAN
l/min	rpm	W	cc/r	l/min	m ³ /h	dB(A)	kg	lt.	mm
50-150	2.700	770	11,3	31	7.000	73	21	3,6	350

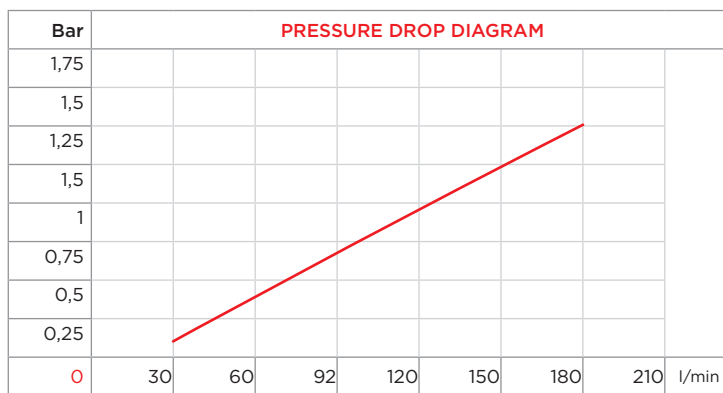
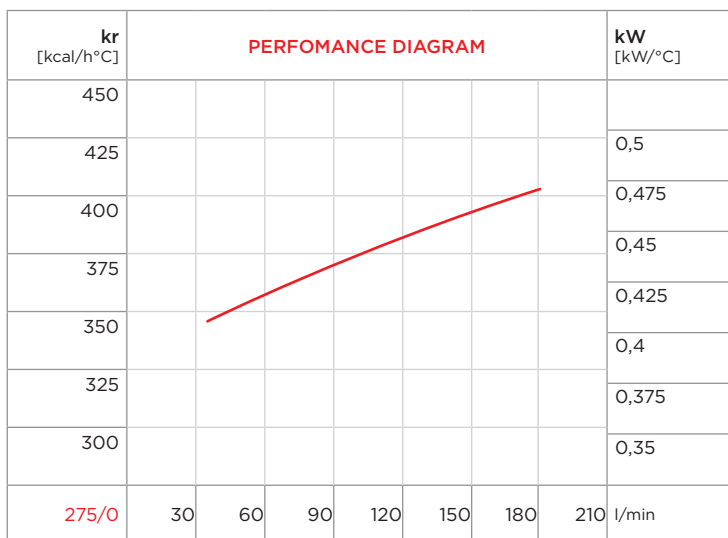

CORRECTION FACTOR							
cSt	22	30	46	68	100	150	220
f	0,6	1	1,5	2,3	3,5	5	7

PURCHASE CODES

AP 430 I with hydraulic motor	3RAP430I1A
AP 430 I prepared	3RAP430I4A

SPARE PARTS

Cooling element	3RNL430
Frame	3CN430I.1
Shock isolating mounting (4 pcs)	3KIT4511
Fan	1G3506345PAV
Fan grill	1RTAP430I
Hydraulic motor	1MO2/M16
Thermo-switch 60-49 IP 65	1TRM60-49
Thermo-switch 47-36 IP 65	1TRM47-36

AP 430/2 I

AIR-OIL HEAT EXCHANGERS WITH IDRAULIC MOTOR
SCAMBIATORI ARIA-OLIO CON MOTORE IDRAULICO



- Dimensions and technical characteristics are not binding

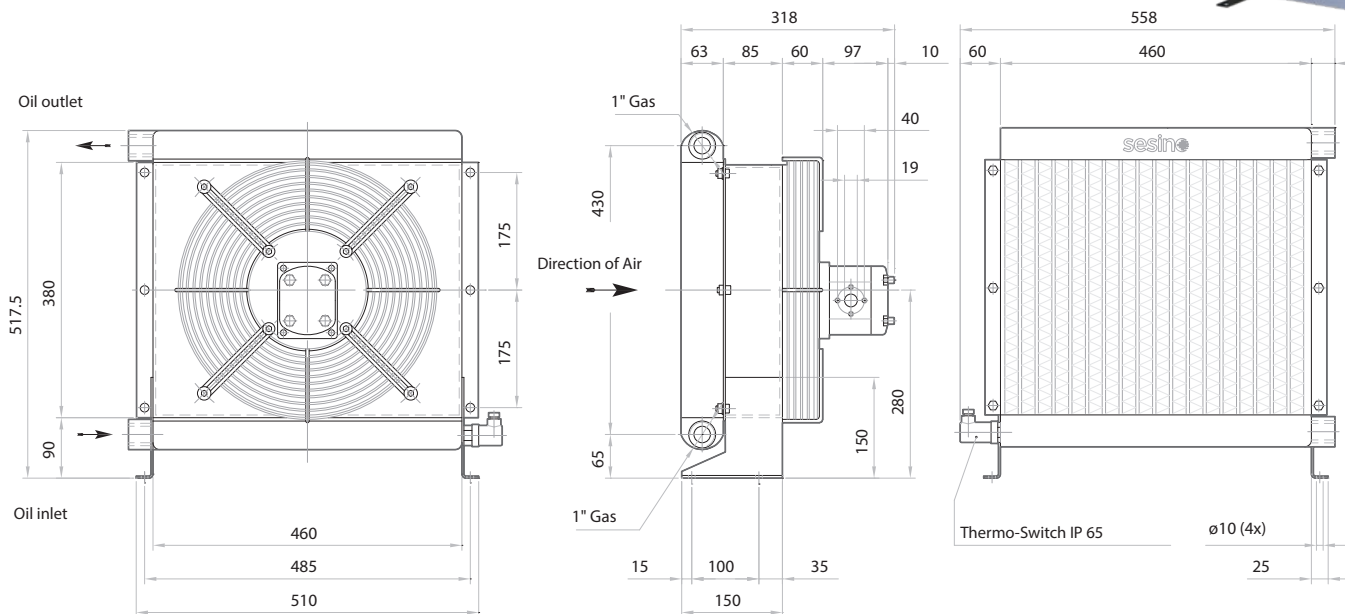

Static working pressure = 20 bar

Test pressure = 35 bar

OIL FLOW	FAN SPEED	POWER	DISPLACEMENT	MOTOR FLOW	AIR FLOW	NOISE LEVEL	WEIGHT	CAPACITY	Ø FAN
l/min	rpm	W	cc/r	l/min	m ³ /h	dB(A)	kg	lt.	mm
30-180	2.700	830	11,3	31	7.000	74	23	5,5	350

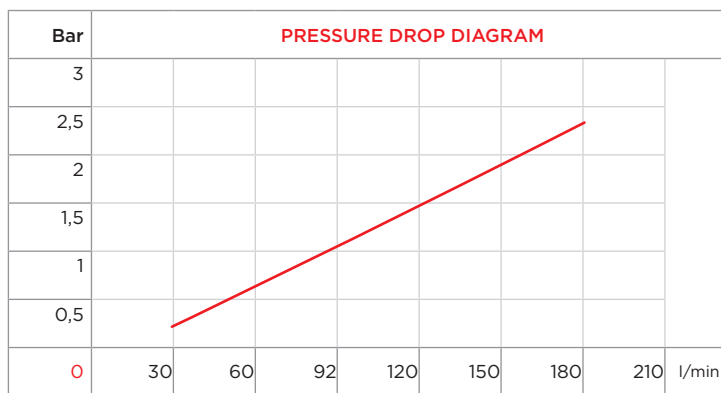
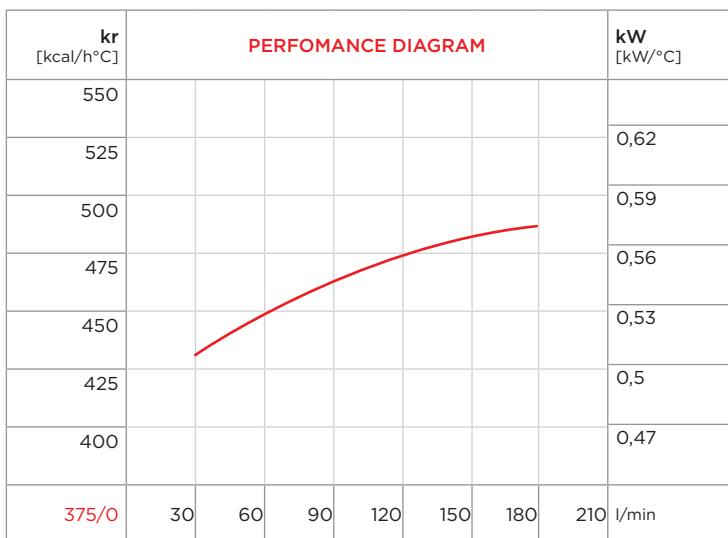

CORRECTION FACTOR

cSt	22	30	46	68	100	150	220
f	0,6	1	1,5	2,3	3,5	5	7

PURCHASE CODES

AP 430/2 I with hydraulic motor	3RAP43211A
AP 430/2 I prepared	3RAP43214A

SPARE PARTS

Cooling element	3RNAP432TP
Frame	3CN430I.1
Shock isolating mounting (4 pcs)	3KIT4511
Fan	1G3506345PAV
Fan grill	1RTAP430I
Hydraulic motor	1MO2/M16
Thermo-switch 60-49 IP 65	1TRM60-49
Thermo-switch 47-36 IP 65	1TRM47-36



- Dimensions and technical characteristics are not binding

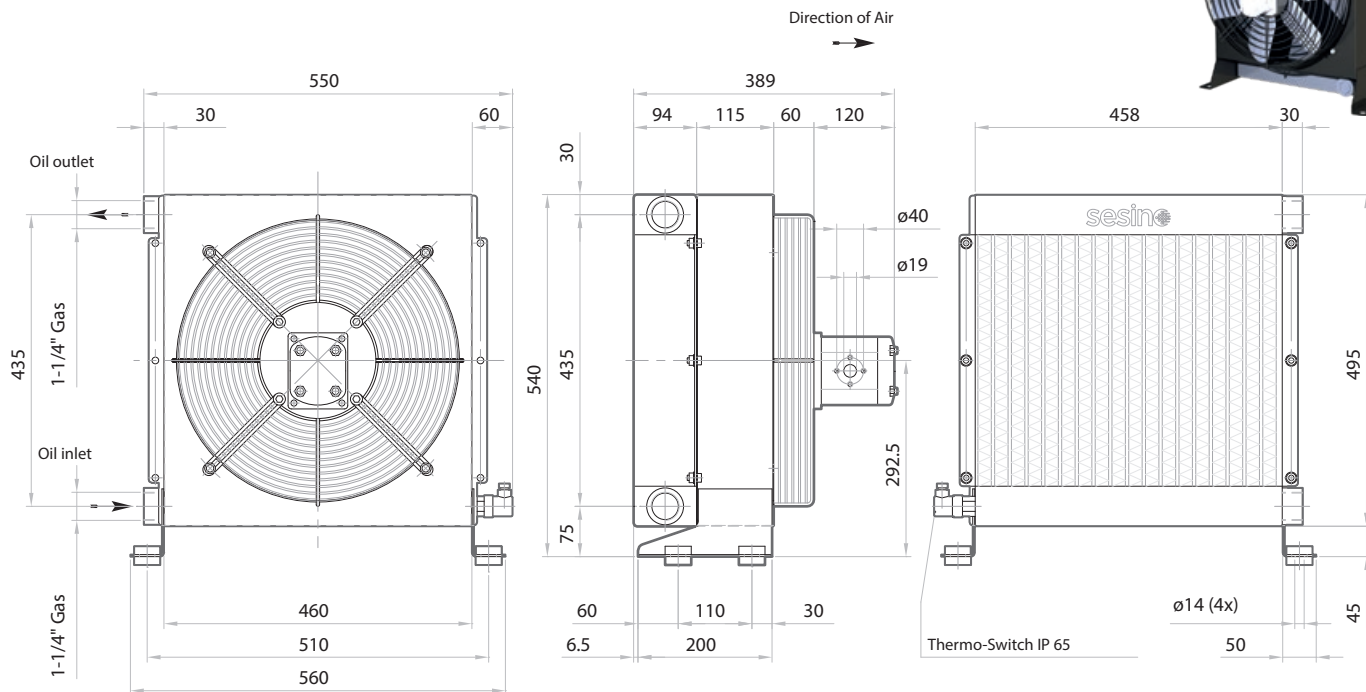

Static working pressure = 20 bar	Test pressure = 35 bar
----------------------------------	------------------------

OIL FLOW	CAPACITY	VOLTAGE	FREQUENCY	POWER	CURRENT	AIR FLOW	PROTECTION	NOISE LEVEL	WEIGHT	ø FAN
l/min	l	V	hz	W	A	m ³ /h	IP	dB(A)	kg	mm
30-240	8	230/400	50	230	1,12/0,65	2.750	54	72	28	400

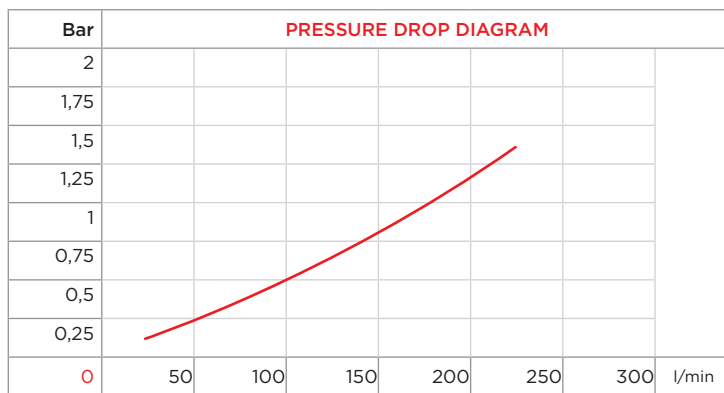
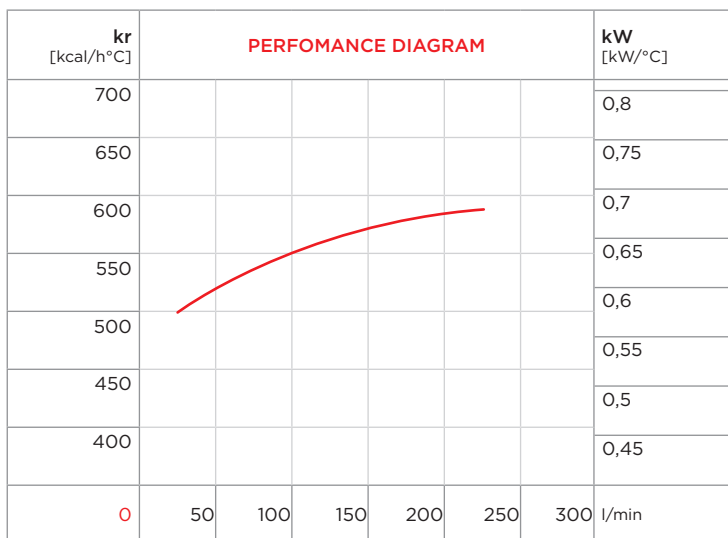

cSt	22	30	46	68	100	150	220
f	0,6	1	1,5	2,3	3,5	5	7

PURCHASE CODES

AP 494 I with hydraulic motor	3RAP49411A
AP 494 I prepared	3RAP49414A

SPARE PARTS

Frame	3CNAP4941.1
Shock isolating mounting (4 pcs)	3KIT4135
Electric junction box for	1CSSDSAREL
Fan	1G40010345PAV
Cooling element	1RO99332
Hydraulic motor	1MO2/M16
Thermo-switch 60-49 IP 65	1TRM60-49
Thermo-switch 47-36 IP 65	1TRM47-36
Fan Grill	1RTAP580I

AP 580 I

AIR-OIL HEAT EXCHANGERS WITH IDRAULIC MOTOR
SCAMBIATORI ARIA-OLIO CON MOTORE IDRAULICO



- Dimensions and technical characteristics are not binding

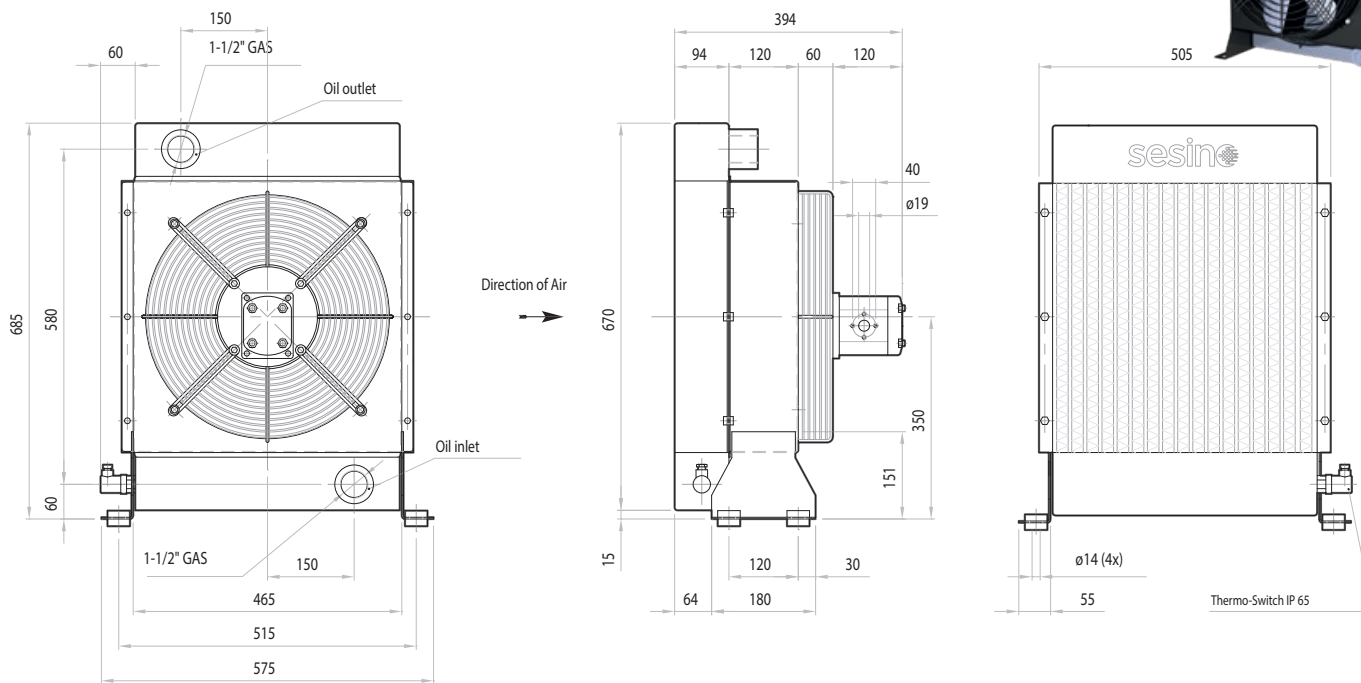

Static working pressure = 20 bar

Test pressure = 35 bar

OIL FLOW	FAN SPEED	POWER	DISPLACEMENT	MOTOR FLOW	AIR FLOW	NOISE LEVEL	WEIGHT	CAPACITY	ø FAN
l/min	rpm	W	cc/r	l/min	m ³ /h	dB(A)	kg	lt.	mm
100-250	2.250	880	11,3	26	8.000	78	38	11,5	400

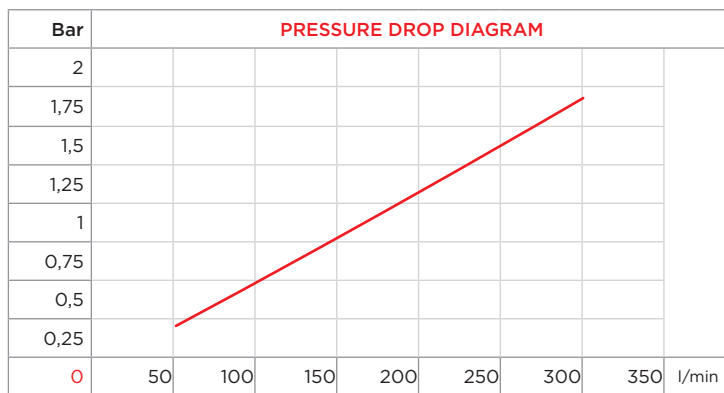
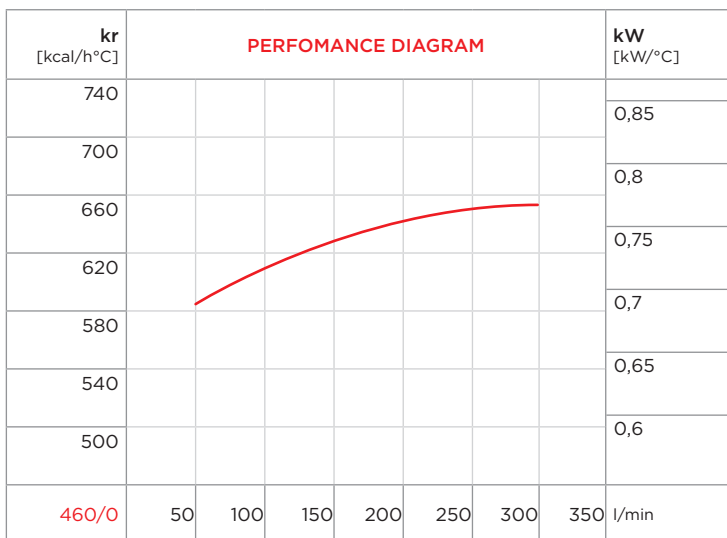

	22	30	46	68	100	150	220
cSt	0,6	1	1,5	2,3	3,5	5	7

PURCHASE CODES

AP 580 I with hydraulic motor	3RAP580I1A
AP 580 I with hydraulic motor	3RAP580I4A

SPARE PARTS

Frame	3CNAP580.1
Shock isolating mounting (4 pcs)	3KIT4135
Cooling element	3RNL580
Fan	1G40010345PAV
Hydraulic motor	1MO2/M16
Thermo-switch 60-49 IP 65	1TRM60-49
Thermo-switch 47-36 IP 65	1TRM47-36
Fan Grill	1RTAP580I



- Dimensions and technical characteristics are not binding

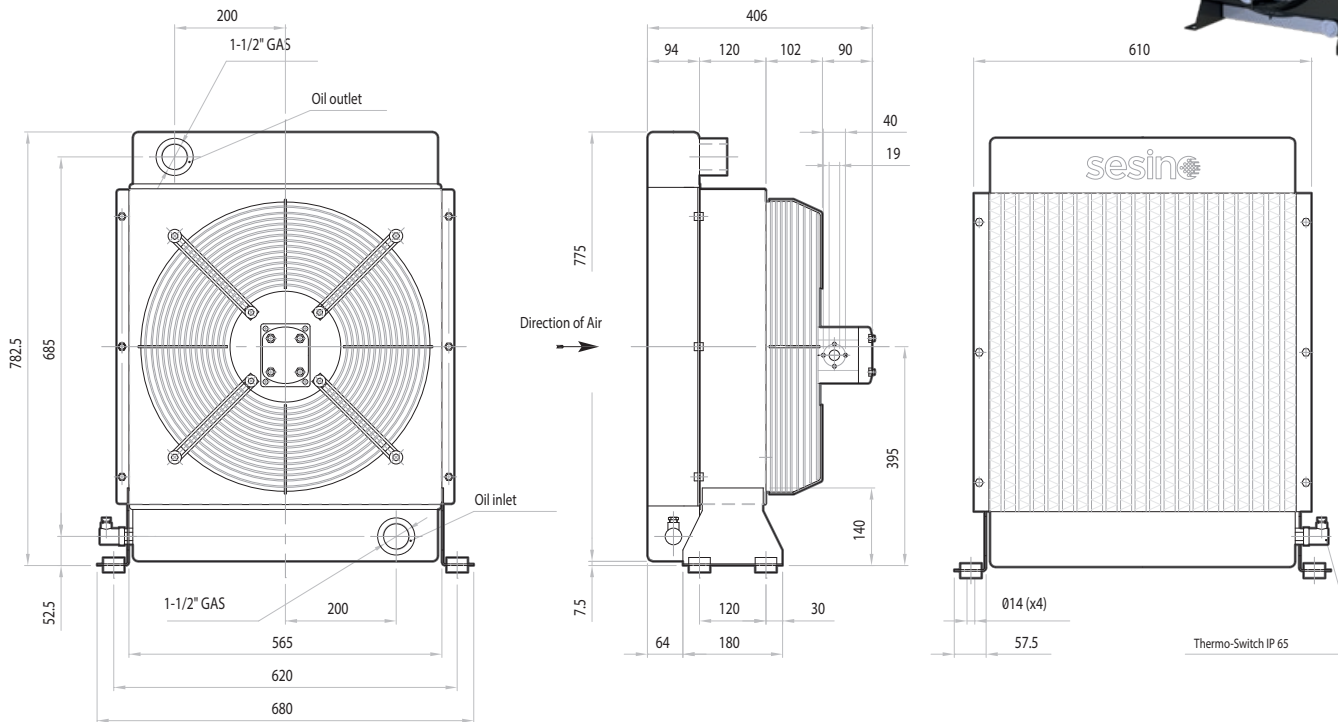

Static working pressure = 20 bar

Test pressure = 35 bar

OIL FLOW	FAN SPEED	POWER	DISPLACEMENT	MOTOR FLOW	AIR FLOW	NOISE LEVEL	WEIGHT	CAPACITY	Ø FAN
l/min	rpm	W	cc/r	l/min	m³/h	dB(A)	kg	lt.	mm
100-300	1.450	750	11,3	17	10.000	80	48	15	500

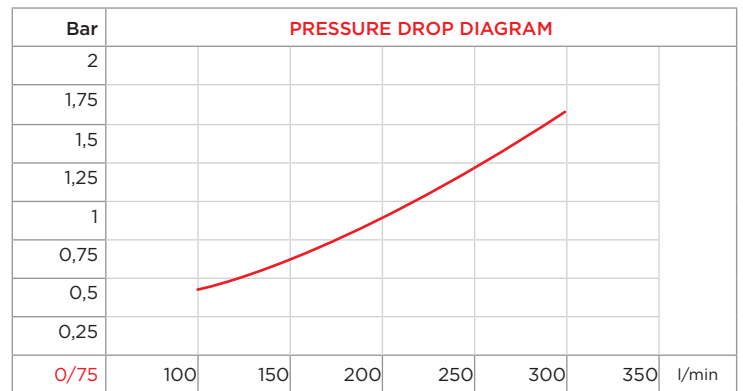
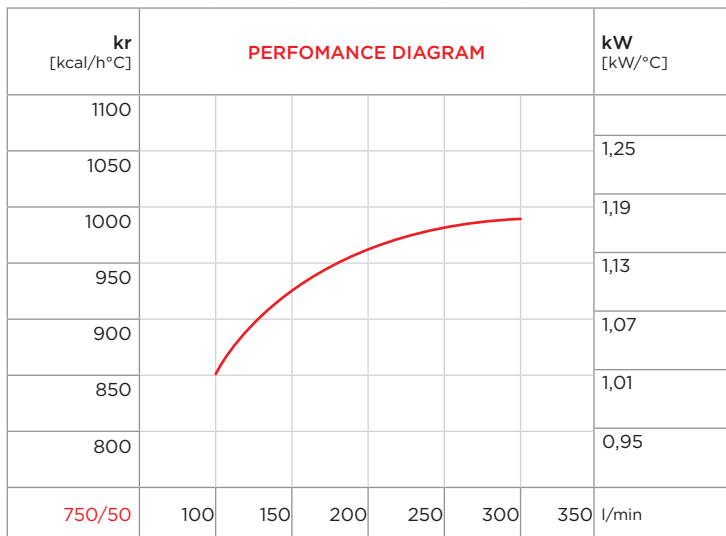

CORRECTION FACTOR							
cSt	22	30	46	68	100	150	220
f	0,6	1	1,5	2,3	3,5	5	7

PURCHASE CODES

AP 680 I with hydraulic motor	3RAP68011A
AP 680 I prepared	3RAP68014A

SPARE PARTS

Frame	3CNAP680.1
Shock isolating mounting (4 pcs)	3KIT4135
Cooling element	3RNAP680E
Hydraulic motor	1MO2/M16
Fan	1G50010340PAV
Thermo-switch 60-49 IP 65	1TRM60-49
Thermo-switch 47-36 IP 65	1TRM47-36
Fan Grill	1RTAP680I

AP 730 I

AIR-OIL HEAT EXCHANGERS WITH IDRAULIC MOTOR SCAMBIATORI ARIA-OLIO CON MOTORE IDRAULICO



- Dimensions and technical characteristics are not binding

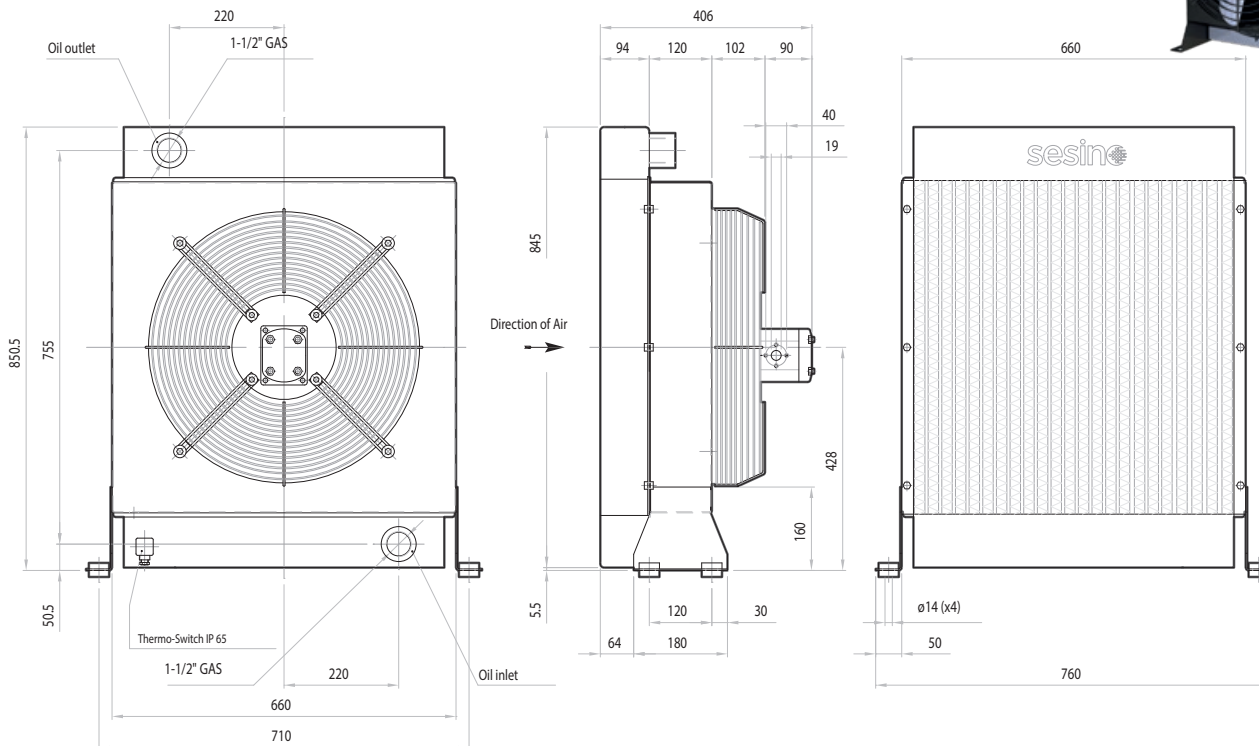

Static working pressure = 20 bar

Test pressure = 35 bar

OIL FLOW	FAN SPEED	POWER	DISPLACEMENT	MOTOR FLOW	AIR FLOW	NOISE LEVEL	WEIGHT	CAPACITY	ø FAN
l/min	rpm	W	cc/r	l/min	m ³ /h	dB(A)	kg	lt.	mm
100-350	1.450	1.000	11,3	17	12.000	80	56	16	600

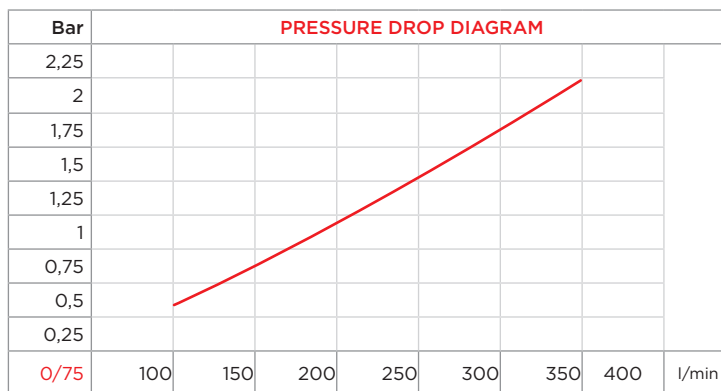
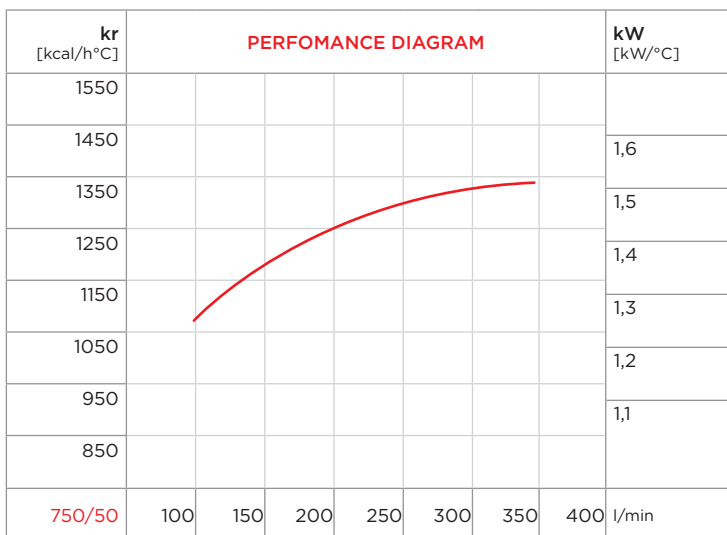

CORRECTION FACTOR

cSt	22	30	46	68	100	150	220
f	0,6	1	1,5	2,3	3,5	5	7

SPARE PARTS

Frame	3CNAP730IA.1
Shock isolating mounting (4 pcs)	3KIT4232
Electric junction box	1CSSDSAREL
Cooling element	3RNAP730E
Fan	1G50010340PAV
Hydraulic motor	1MO2/M16
Thermo-switch 60-49 IP 65	1TRM60-49
Thermo-switch 47-36 IP 65	1TRM47-36
Fan Grill	1RTAP680I

PURCHASE CODES

AP 730 I with hydraulic motor	3RAP730I1A
AP 730 I prepared	3RAP730I4A

AP 830 I

AIR-OIL HEAT EXCHANGERS WITH IDRAULIC MOTOR
SCAMBIATORI ARIA-OLIO CON MOTORE IDRAULICO



- Dimensions and technical characteristics are not binding

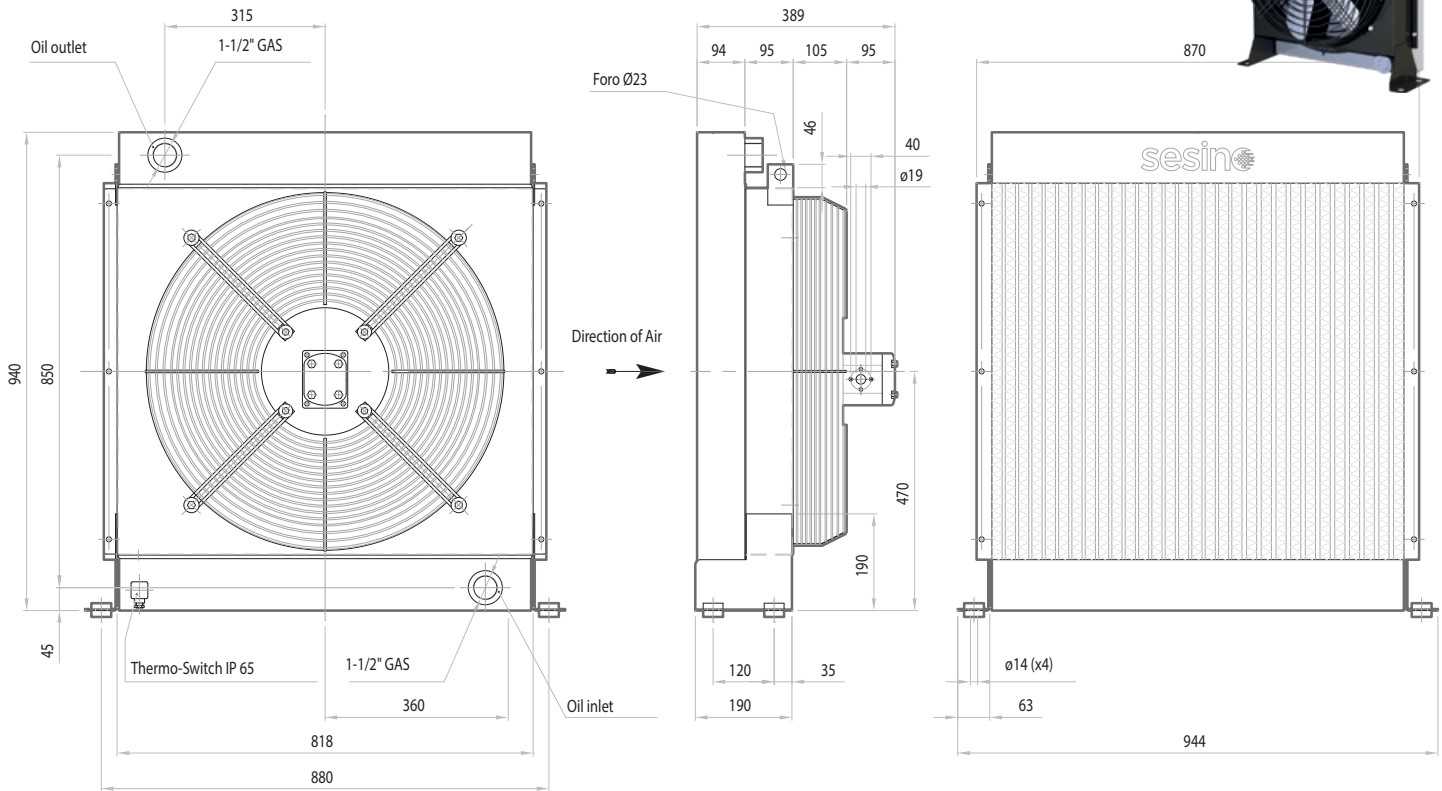

Static working pressure = 20 bar

Test pressure = 35 bar

OIL FLOW	FAN SPEED	POWER	DISPLACEMENT	MOTOR FLOW	AIR FLOW	NOISE LEVEL	WEIGHT	CAPACITY	Ø FAN
l/min	rpm	W	cc/r	l/min	m ³ /h	dB(A)	kg	lt.	mm
150-400	1.300	1.300	17,5	23	15.000	82	74,5	20	680

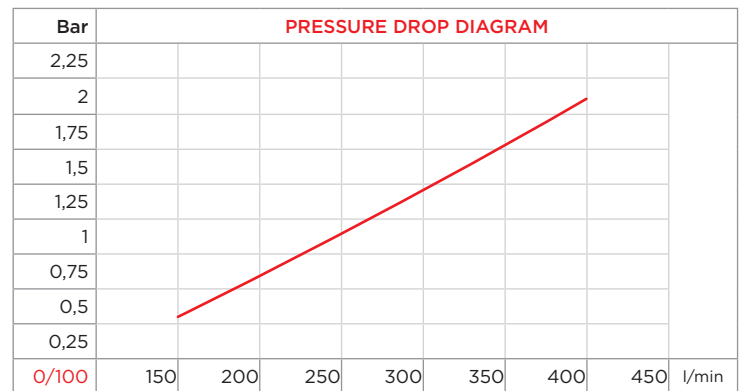
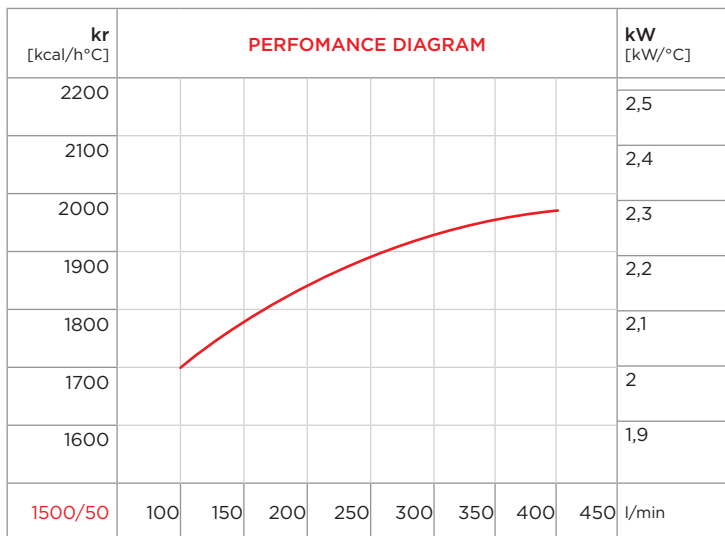

CORRECTION FACTOR

cSt	22	30	46	68	100	150	220
f	0,6	1	1,5	2,3	3,5	5	7

PURCHASE CODES

AP 830 I with hydraulic motor	3RAP83012A
AP 830 I prepared	3RAP83014A

SPARE PARTS

Frame	3CNAP830IA.1
Shock isolating mounting (4 pcs)	3KIT4232
Electric junction box	1CSSDSAREL
Cooling element	3RNAP830E
Fan	1G68094Z30PAV
Hydraulic motor	1MO2/M25
Thermo-switch 60-49 IP 65	1TRM60-49
Thermo-switch 47-36 IP 65	1TRM47-36
Fan Grill	1RTAP830I

AP 2/680 I

AIR-OIL HEAT EXCHANGERS WITH IDRAULIC MOTOR
SCAMBIATORI ARIA-OLIO CON MOTORE IDRAULICO



- Dimensions and technical characteristics are not binding

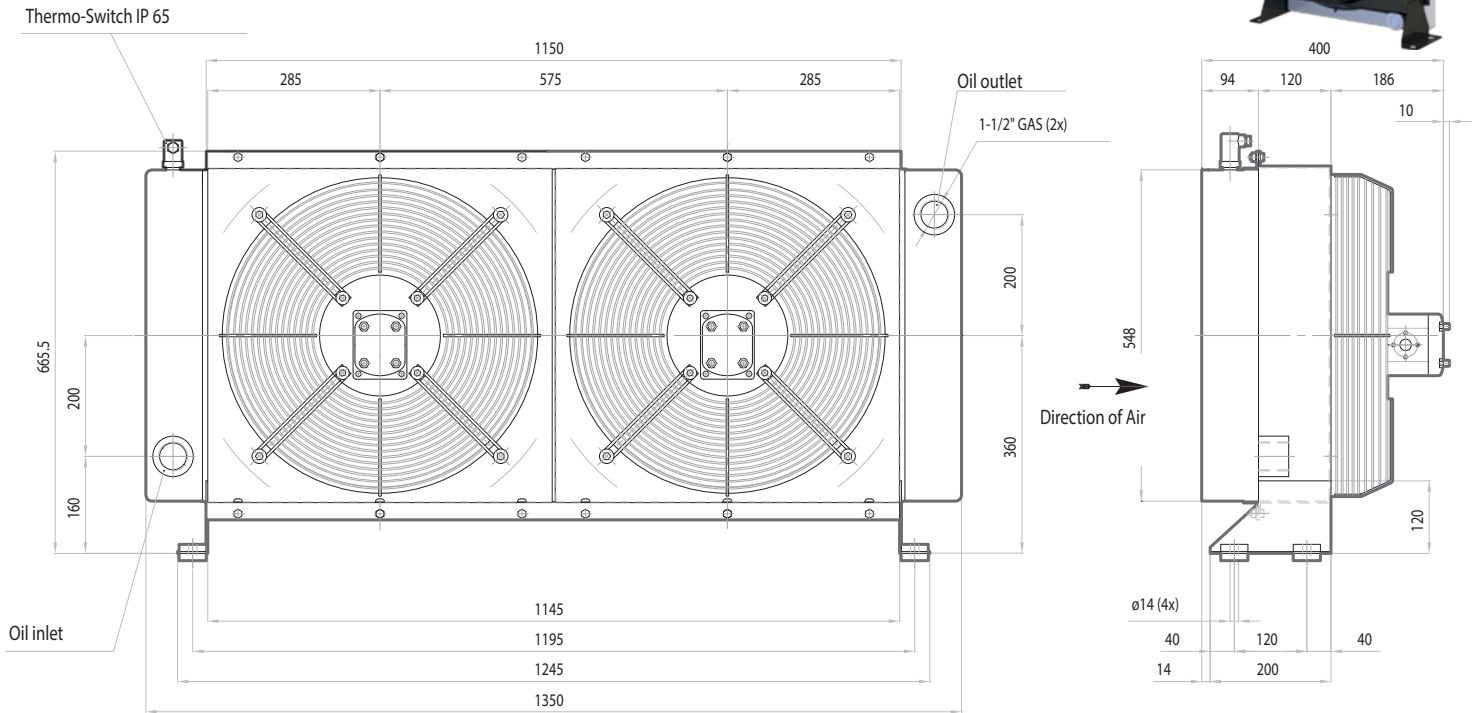

Static working pressure = 20 bar

Test pressure = 35 bar

OIL FLOW	FAN SPEED	POWER	DISPLACEMENT	MOTOR FLOW	AIR FLOW	NOISE LEVEL	WEIGHT	CAPACITY	ø FAN
l/min	rpm	W	cc/r	l/min	m ³ /h	dB(A)	kg	lt.	mm
100-300	2x1.450	2x750	2x11,3	2x17	2x10.000	82	100	28	2x500

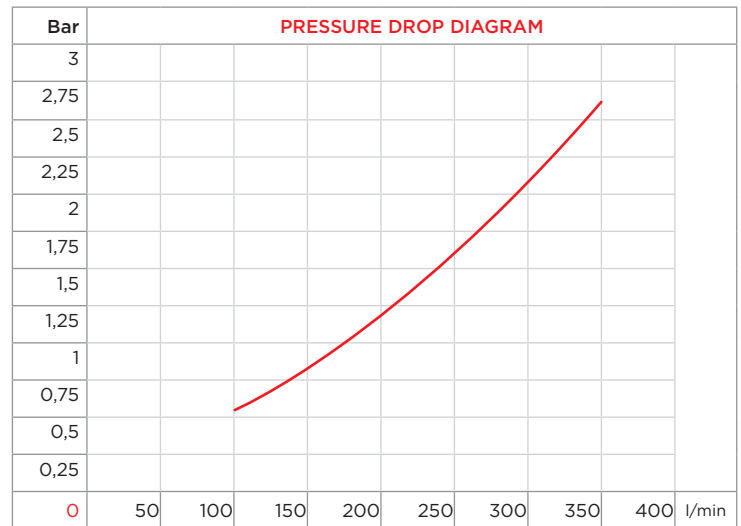
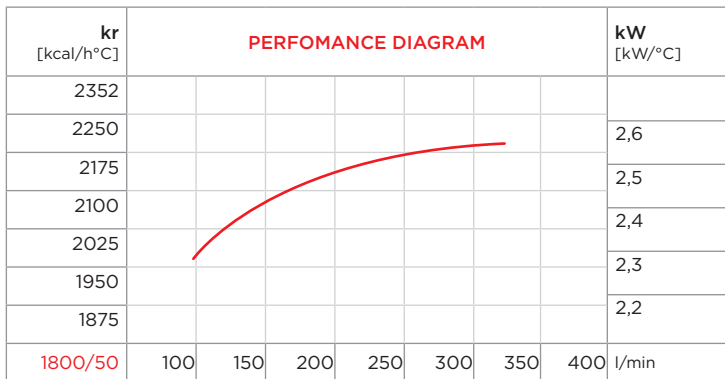

CORRECTION FACTOR							
cSt	22	30	46	68	100	150	220
f	0,6	1	1,5	2,3	3,5	5	7

SPARE PARTS

Frame	3CNAP2/6800.1
Shock isolating mounting (4 pcs)	3KIT4232
Electric junction box	1CSSDSAREL
Cooling element	1RO01339
Fan	1G3506345PAV
Hydraulic motor	1MO2/M16
Thermo-switch 60-49 IP 65	1TRM60-49
Thermo-switch 47-36 IP 65	1TRM47-36
Fan Grill	1RTAP680I

PURCHASE CODES

AP 2/680 I with hydraulic motor	3RAP2/680I1A
AP 2/680 I prepared	3RAP2/680I4A



- Dimensions and technical characteristics are not binding

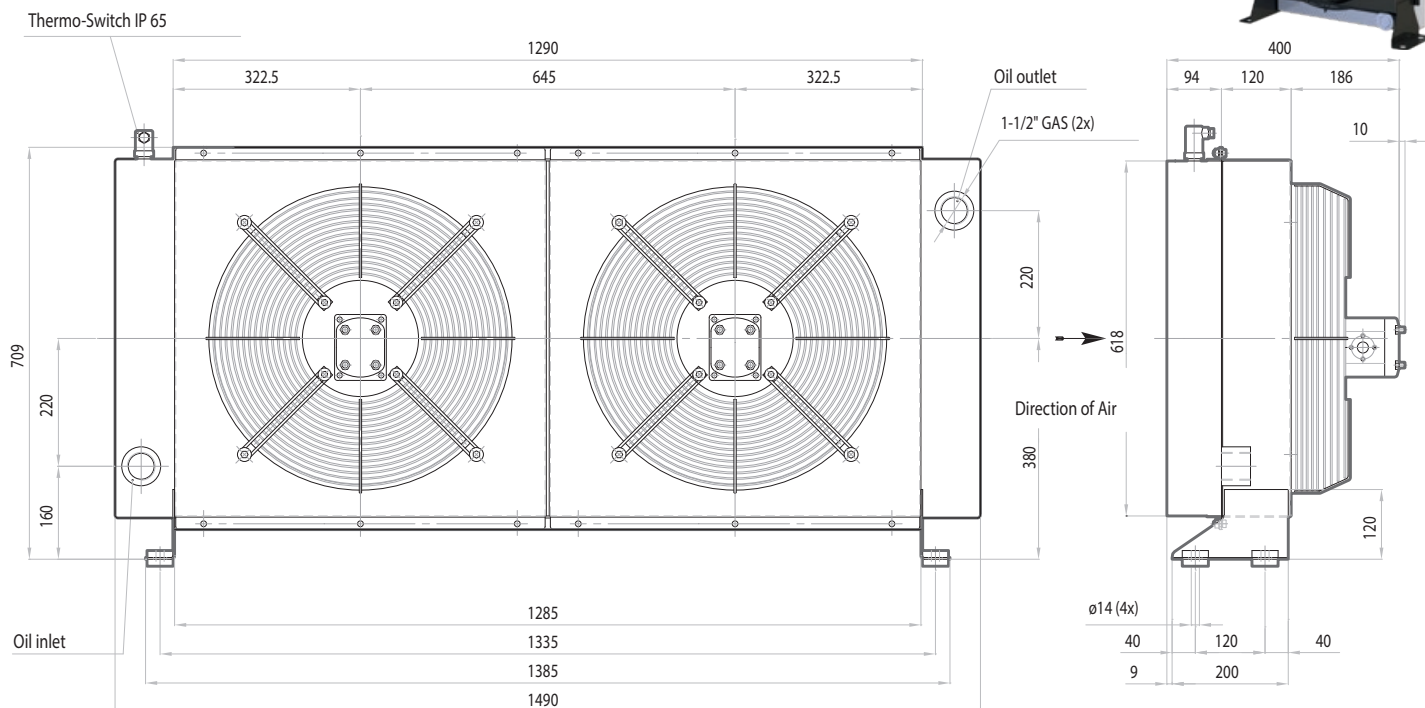

Static working pressure = 20 bar

Test pressure = 35 bar

OIL FLOW	FAN SPEED	POWER	DISPLACEMENT	MOTOR FLOW	AIR FLOW	NOISE LEVEL	WEIGHT	CAPACITY	Ø FAN
l/min	rpm	W	cc/r	l/min	m ³ /h	dB(A)	kg	lt.	mm
100-350	1.450	2x1.000	2x11,3	2x17	2x12.000	82	120	30	2x600

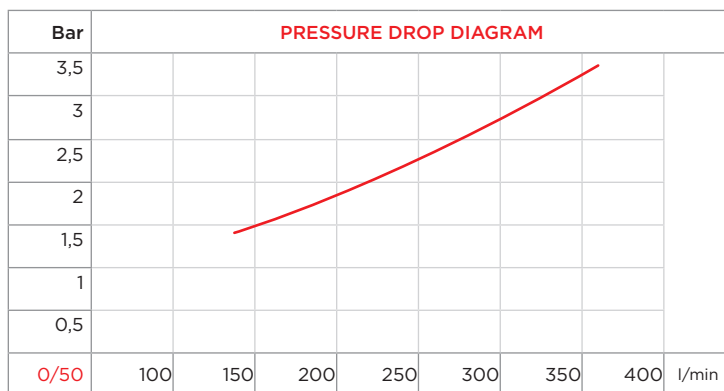
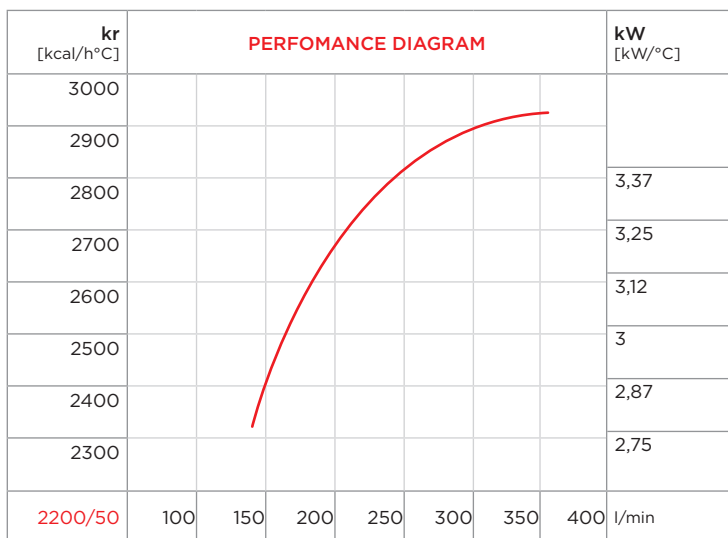

CORRECTION FACTOR

cSt	22	30	46	68	100	150	220
f	0,6	1	1,5	2,3	3,5	5	7

PURCHASE CODES

AP 2/730 I with hydraulic motor	3RAP2/730I1A
AP 2/730 I prepared	3RAP2/730I4A

SPARE PARTS

Frame	3CNAP2/730I1
Shock isolating mounting (4 pcs)	3KIT4232
Electric junction box	1CSSDSAREL
Cooling element	1RO02357
Fan	1G50010340PAV
Hydraulic motor	1MO2/M16
Thermo-switch 60-49 IP 65	1TRM60-49
Thermo-switch 47-36 IP 65	1TRM47-36
Fan Grill	1RTAP680I

AP 2/830 I

AIR-OIL HEAT EXCHANGERS WITH IDRAULIC MOTOR
SCAMBIATORI ARIA-OLIO CON MOTORE IDRAULICO



- Dimensions and technical characteristics are not binding

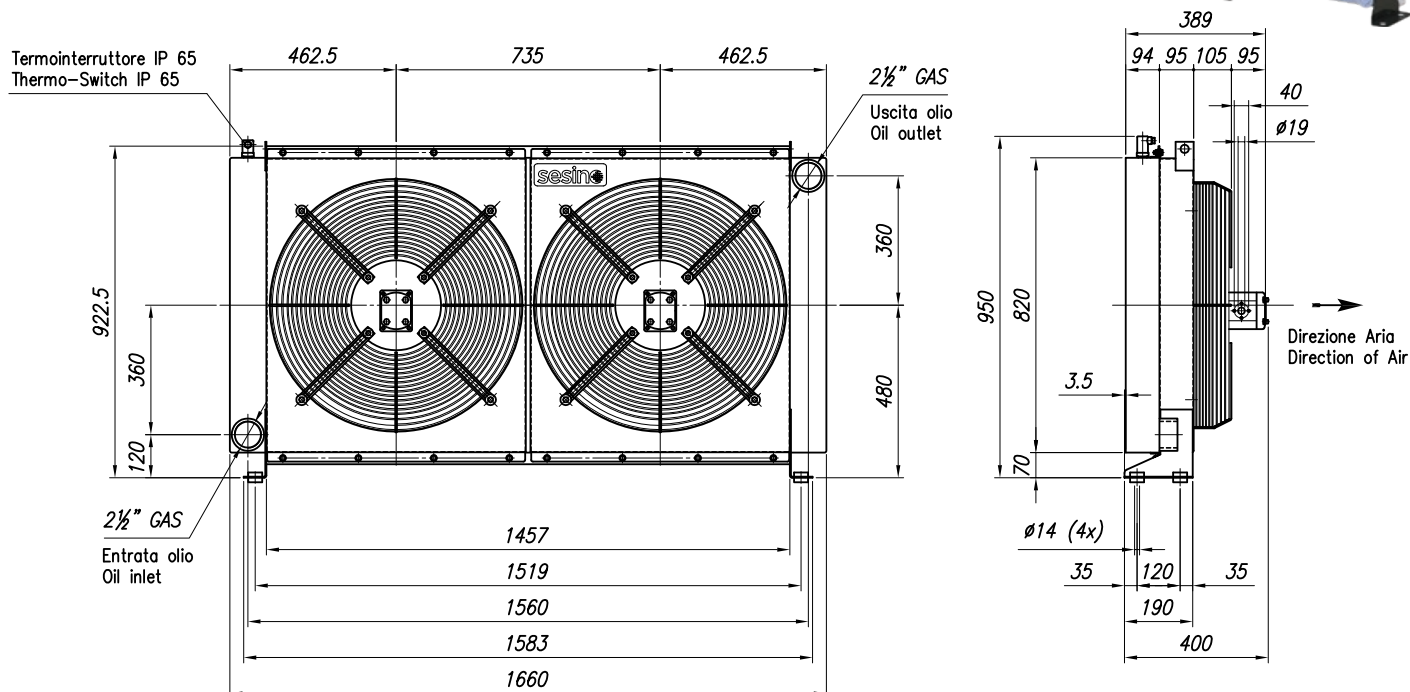

Static working pressure = 20 bar

Test pressure = 35 bar

OIL FLOW	FAN SPEED	POWER	DISPLACEMENT	MOTOR FLOW	AIR FLOW	NOISE LEVEL	WEIGHT	CAPACITY	ø FAN
l/min	rpm	W	cc/r	l/min	m ³ /h	dB(A)	kg	lt.	mm
150-400	2x1.300	2x1.300	2x17,5	2x23	2x15.000	82	148	40	2x680

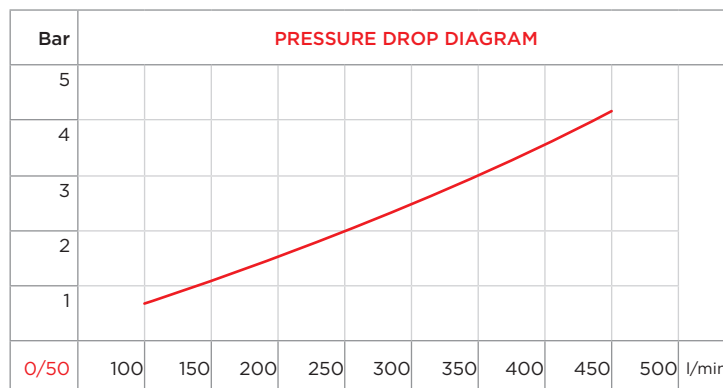
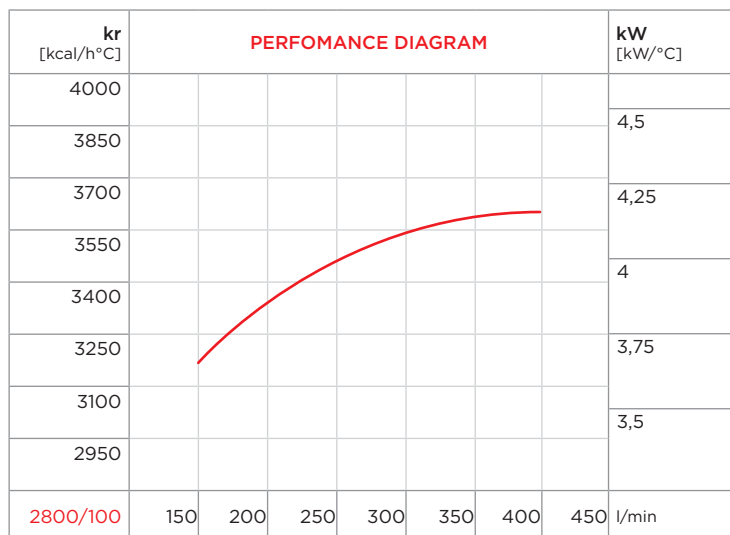

CORRECTION FACTOR

cSt	22	30	46	68	100	150	220
f	0,6	1	1,5	2,3	3,5	5	7

PURCHASE CODES

AP 2/830 I with hydraulic motor	3RAP2/830I2A
AP 2/830 I prepared	3RAP2/830I4A

SPARE PARTS

Frame	3CNAP2/830I.1
Shock isolating mounting (4 pcs)	3KIT4232
Electric junction box	1CSSDSAREL
Cooling element	3RNAP2/830
Fan	1G68094Z30PAV
Hydraulic motor	1MO2/M25
Thermo-switch 60-49 IP 65	1TRM60-49
Thermo-switch 47-36 IP 65	1TRM47-36
Fan Grill	1RTAP830I

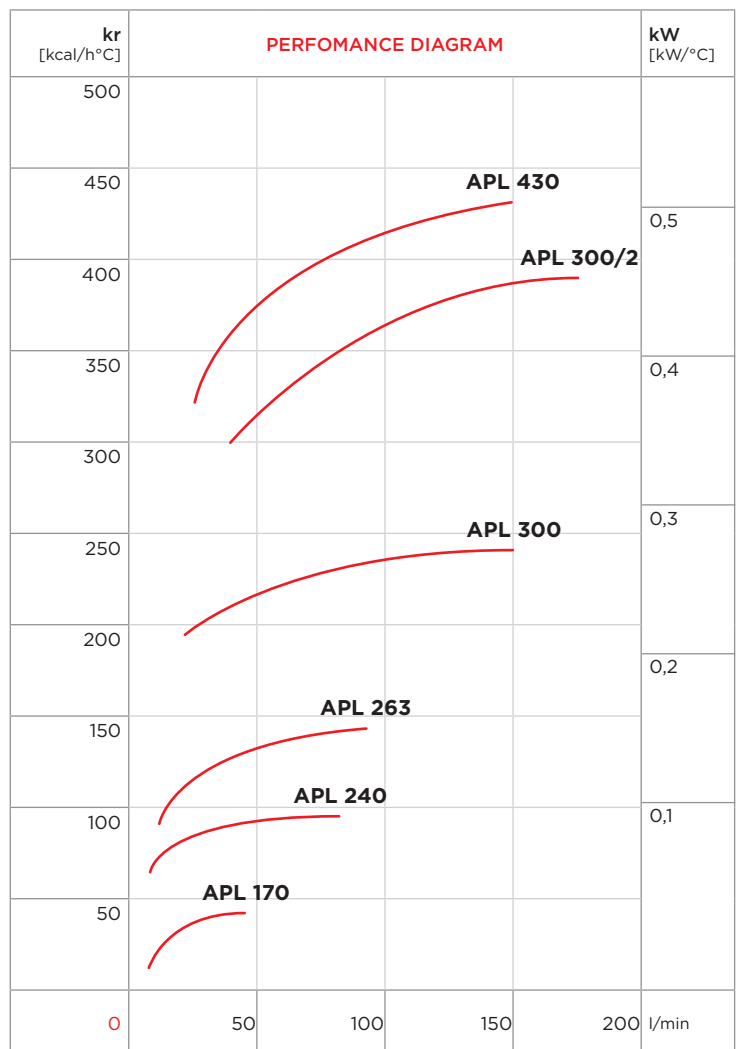
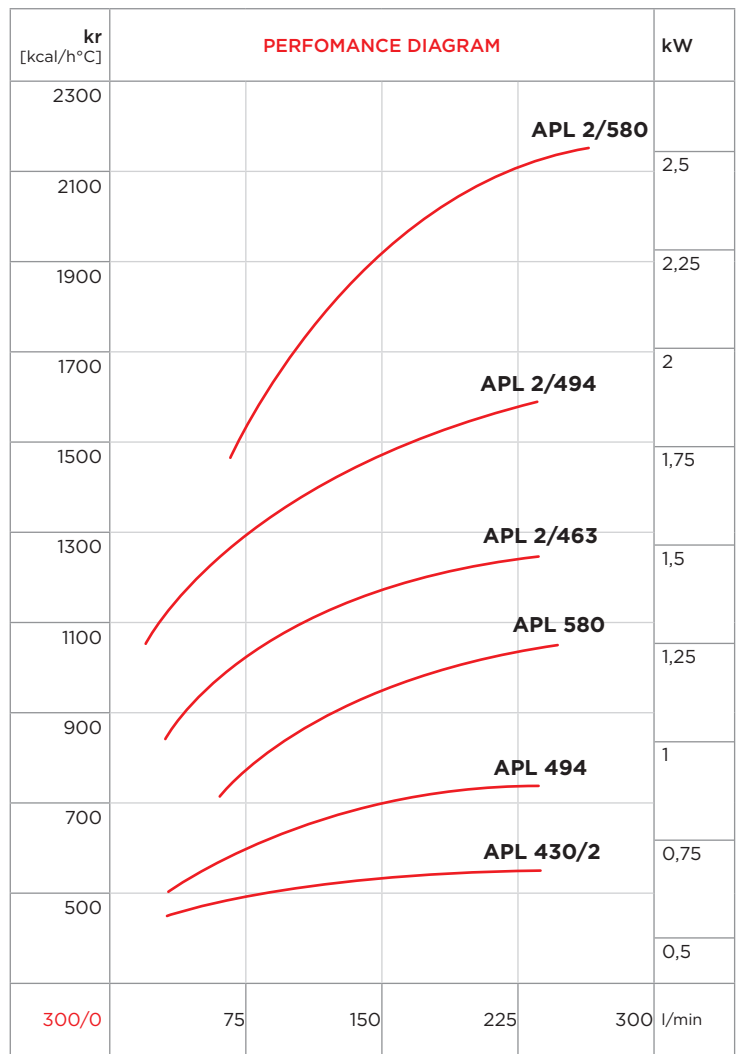
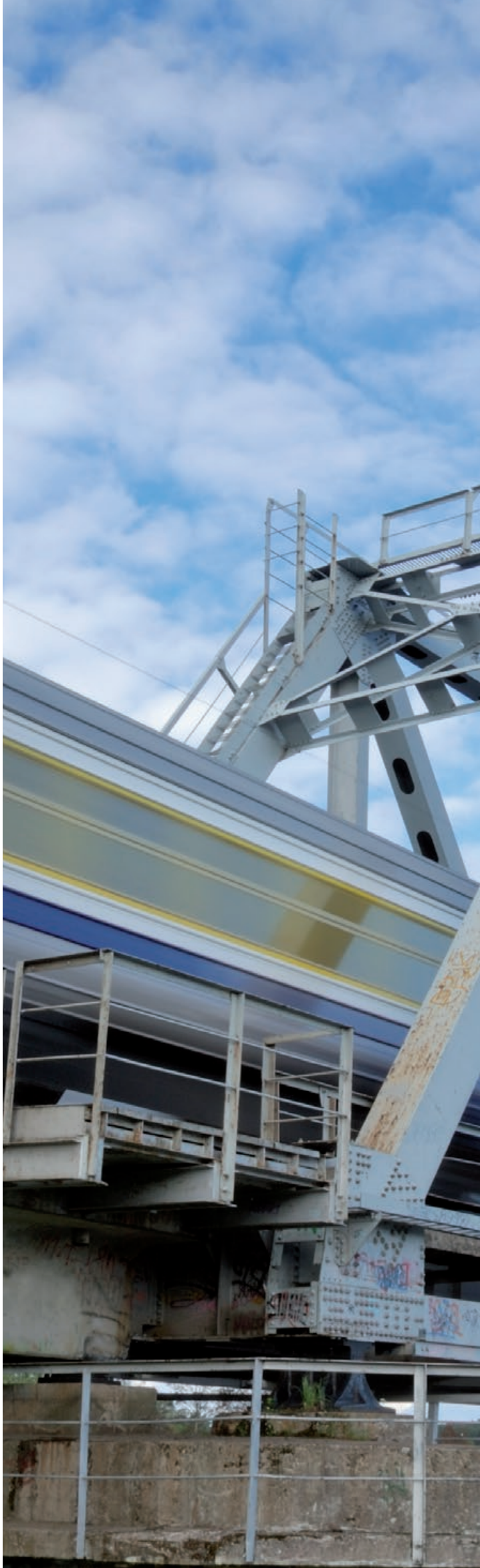

DC AIR-OIL HEAT EXCHANGERS

SCAMBIATORI DI CALORE ARIA OLIO CON VENTILATORE A CORRENTE CONTINUA



These type of exchangers are particularly suitable to cool oleo hydraulic systems of mobile machines, having fans at 12V or 24V to be connected to the battery of the machine.

The particular structure of the cooling element allows great thermic performances and pressure resistance. **Maximum working static pressure: 20 bar.**

Our technical Department is available to suggest and find the better solution in case of particular working conditions, pressures, frequencies, vibrations, etc.

It is always recommended to assemble in parallel with the exchanger a by-pass valve to avoid extreme counter-pressures, particularly when the machine is started with cold oil. On the contrary, it is not useful to use a check valve as by-pass to protect the exchanger from pressure's peaks, since the inertia of the valve itself is too high in comparison with the speed of the pressure waves that occur into the oleo hydraulic systems.

The flow rates shown in the tables are the ones recommended for the exchanger proper working.

The efficiency curves show the specific exchange capacity in kcal/h°C or in kW/h°C according to the different oil rates. To calculate the heat quantity the different exchangers are able to dissipate it is enough to multiply such capacity by the difference between the requested oil temperature and the summer room temperature.

We pay particular attention to the choice of our components in order to supply the customer with a reliable product.

Long lasting fans with IP68 electric protection and thermo switches with IP67 protection, available with two temperature ranges, 47°C or 60°C.

The thermo switch calibration shows the initial temperature of the fans, while the stop temperature is 11°C lower. We must consider that the tolerance on the above mentioned operating temperatures is 35°C.

The electric system of these exchangers is already wired.

If the exchanger is equipped with thermo switch, the electric system has a relay integrated into the thermo switch itself.

The carbon steel parts are power painted in order to resist to corrosive phenomena.

For the right calculation of air-oil heat exchangers, we supply our customers with a calculation program.

The air-oil heat exchangers can be used to cool other kind of fluids, which must be compatible with aluminum and its alloys.

However, for each use, with the exception of oil cooling, we recommend to consult our Technical Department.

*Questi tipi di scambiatori trovano impiego per il raffreddamento di impianti oleoidraulici su macchine mobili, essendo equipaggiati da ventilatori a 12 o 24 V, da collegare quindi alla batteria della macchina. La particolare costruzione del radiatore consente di ottenere notevoli rese termiche e forte resistenza alla pressione; **pressione massima statica di funzionamento: 20 bar.***

Il nostro Ufficio Tecnico è a disposizione per valutare la soluzione più opportuna in presenza di particolari condizioni di lavoro, pressioni, frequenze, vibrazioni, ecc..

È sempre consigliabile montare in parallelo allo scambiatore una valvola di by-pass per evitare eccessive contropressioni soprattutto al momento dell'avviamento della macchina con olio freddo.

Il radiatore può essere eventualmente fornito con una valvola di by-pass integrata o esterna.

Non è invece conveniente utilizzare una valvola di ritegno come by-pass per proteggere lo scambiatore dai picchi di pressione in quanto l'inerzia della valvola stessa è troppo alta rispetto alla velocità delle onde di pressione che si sviluppano all'interno dell'olio degli impianti oleoidraulici.

Le portate olio indicate nelle tabelle sono quelle consigliate per il buon funzionamento dello scambiatore.

Le curve di rendimento forniscono la potenzialità di scambio specifica in kcal/h°C o in kW/h°C in funzione della portata olio; per calcolare la quantità di calore che i vari scambiatori sono in grado di disperdere, è sufficiente moltiplicare tale potenzialità per la differenza tra le temperature dell'olio desiderata e dell'aria ambiente massima estiva. Particolare attenzione è stata posta nella scelta dei componenti per fornire alla clientela un prodotto estremamente affidabile. In particolare, i ventilatori sono stati scelti a lunga durata e con una protezione elettrica IP68, così come il termostato fisso, disponibile nelle due diverse tarature 47° e 60°C e con una protezione elettrica IP67.

La temperatura dei termostati indica la temperatura di partenza dei ventilatori; quella di arresto è di 11°C inferiore.

Bisogna inoltre considerare che la tolleranza sulle temperature di intervento di cui sopra è di ±5°C

Gli scambiatori di questa serie sono forniti con l'impianto elettrico già cablato.

Nel caso lo scambiatore sia munito di termostato, l'impianto elettrico è sempre completato da un relè incorporato nel termostato stesso.

Le parti in lamiera d'acciaio al carbonio, per resistere ai fenomeni corrosivi presenti nell'applicazione su macchine mobili, sono verniciate con vernice a polvere e successivamente passate in forno.

Per il calcolo degli scambiatori aria-olio è disponibile un programma.

Gli scambiatori aria-olio possono essere utilizzati per raffreddare altri tipi di fluidi, a condizione che essi siano compatibili con l'alluminio e le sue leghe.

Consigliamo comunque, per qualsiasi impiego che non sia il raffreddamento dell'olio, di contattare il nostro Ufficio Tecnico.



- Dimensions and technical characteristics are not binding

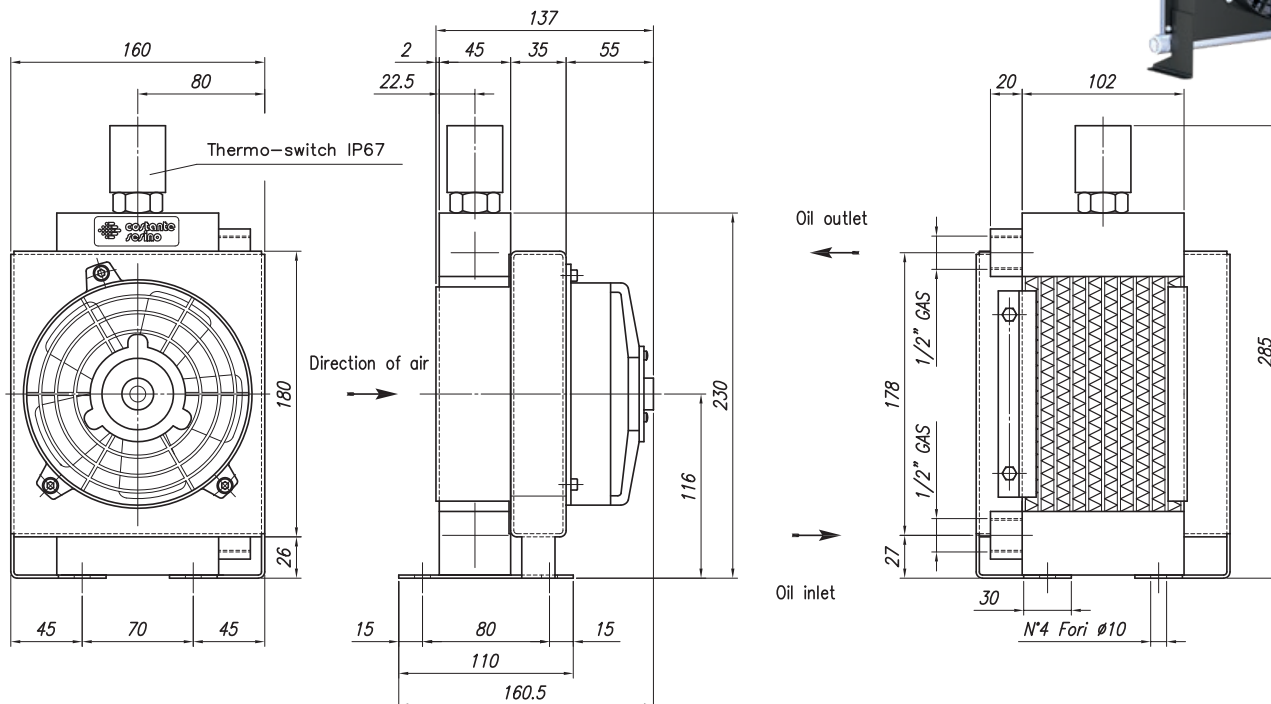

Static working pressure = 20 bar

Test pressure = 35 bar

OIL FLOW	VOLTAGE	POWER	CURRENT	AIR FLOW	ELECTRIC PROTECTION	NOISE LEVEL	WEIGHT	CAPACITY	ø FAN
l/min	V	W	A	m ³ /h	IP	dB(A)	kg	lt.	mm
5-40	12	65	5,4	400	65	70	3	0,5	130
5-40	24	65	2,7	400	65	70	3	0,5	130

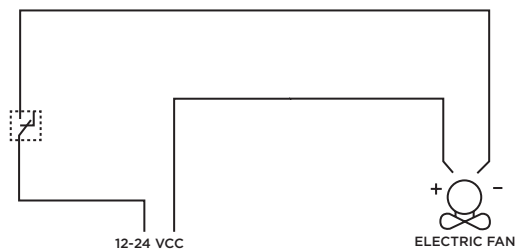
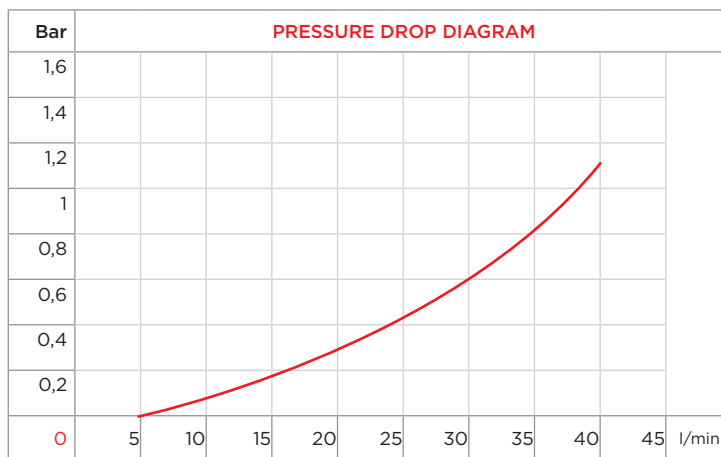
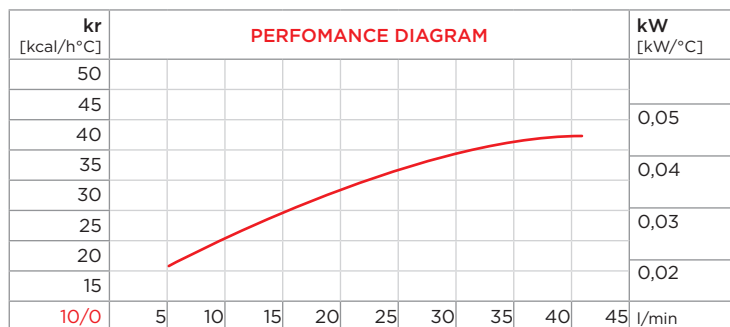

CORRECTION FACTOR							
cSt	22	30	46	68	100	150	220
f	0,6	1	1,5	2,3	3,5	5	7

PURCHASE CODES

APL 170 12/24V without thermo switch	3RL17012 / 3RL17024
APL 170 12/24V with thermo switch	3RL17012T247 / 3RL17024T247 3RL17012T260 / 3RL17024T260

SPARE PARTS

Thermo-switch 47-36 12V IP 67	1TRM47-36/12V
Thermo-switch 47-36 24V IP 67	1TRM47-36/24V
Thermo-switch 60-49 12V IP 67	1TRM60-49/12V
Thermo-switch 60-49 24V IP 67	1TRM60-49/24V
Cooling element	1RO92302
Frame	3CNL170.1
Frame support	3STFL170.1
12VDC Electric fan	1MCVA37A101A
24VDC Electric fan	1MCVA37B101A



- Dimensions and technical characteristics are not binding

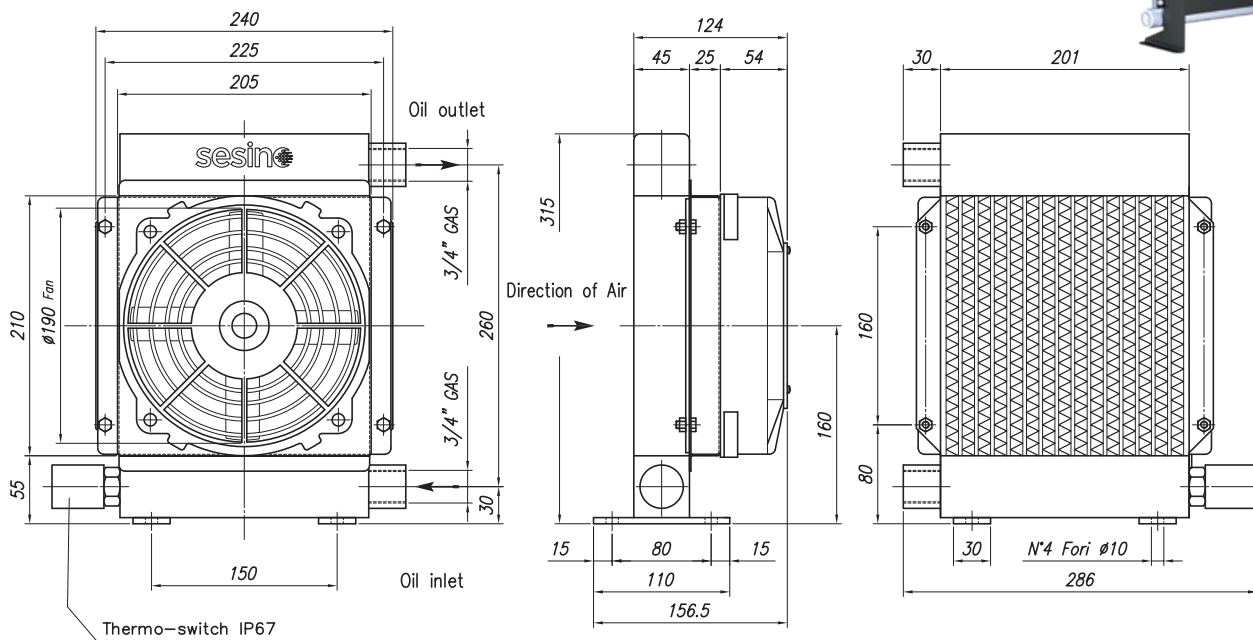

Static working pressure = 20 bar

Test pressure = 35 bar

OIL FLOW	VOLTAGE	POWER	CURRENT	AIR FLOW	ELECTRIC PROTECTION	NOISE LEV.	WEIGHT	CAPACITY	ø FAN
l/min	V	W	A	m³/h	IP	dB(A)	kg	lt.	mm
10-80	12	65	5,4	500	64	72	5	1	190
10-80	24	65	2,7	500	64	72	5	1	190

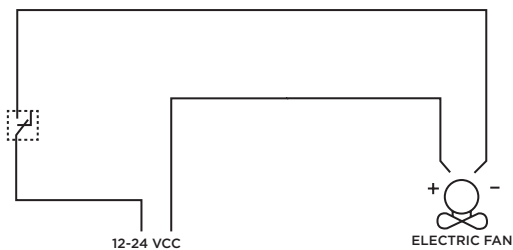
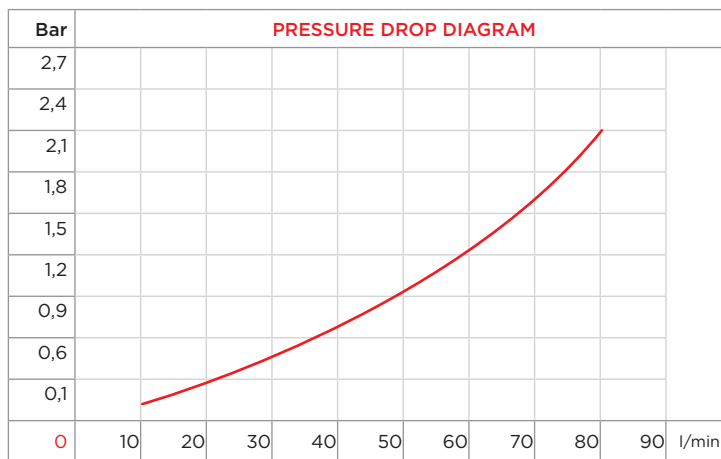
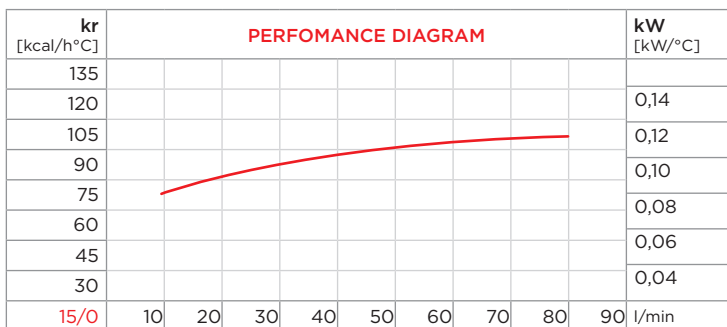

CORRECTION FACTOR

cSt	22	30	46	68	100	150	220
f	0,6	1	1,5	2,3	3,5	5	7

PURCHASE CODES

APL 240 12/24V without thermo switch	3RL24012 / 3RL24024
APL 240 12/24V with thermo switch	3RL24012T247 / 3RL24024T247 3RL24012T260 / 3RL24024T260

SPARE PARTS

Thermo-switch 47-36 12V IP 67	1TRM47-36/12V
Thermo-switch 47-36 24V IP 67	1TRM47-36/24V
Thermo-switch 60-49 12V IP 67	1TRM60-49/12V
Thermo-switch 60-49 24V IP 67	1TRM60-49/24V
Cooling element	3RNAP260
Frame	3CNAP260.1
12VDC Electric fan	1MCVA14AP7AC
24VDC Electric fan	1MCVA14BP7AC



- Dimensions and technical characteristics are not binding

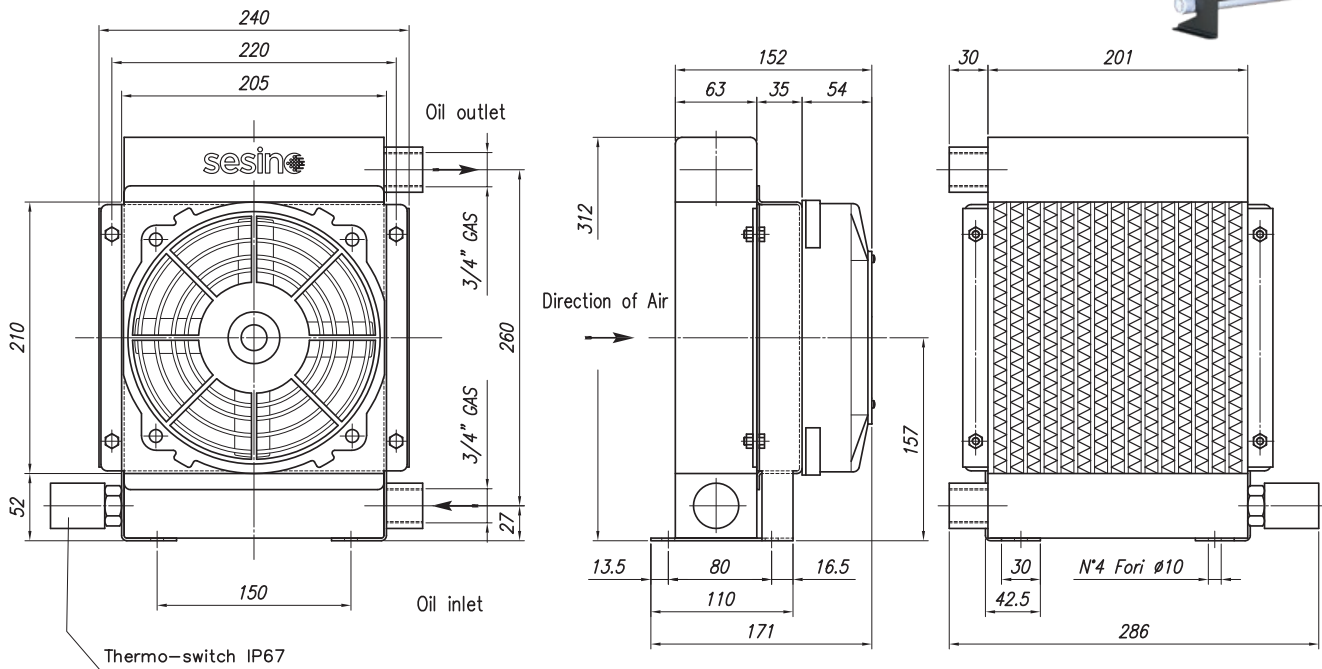

Static working pressure = 20 bar

Test pressure = 35 bar

OIL FLOW	VOLTAGE	POWER	CURRENT	AIR FLOW	ELECTRIC PROTECTION	NOISE LEV.	WEIGHT	CAPACITY	Ø FAN
l/min	V	W	A	m ³ /h	IP	dB(A)	kg	lt.	mm
10-80	12	65	5,2	500	64	72	5	1	190
10-80	24	65	2,6	500	64	72	5	1	190

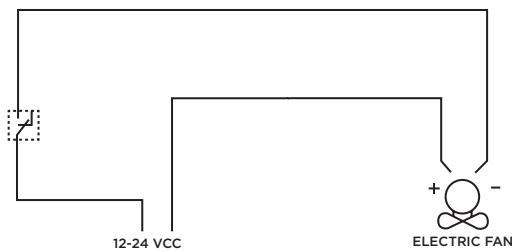
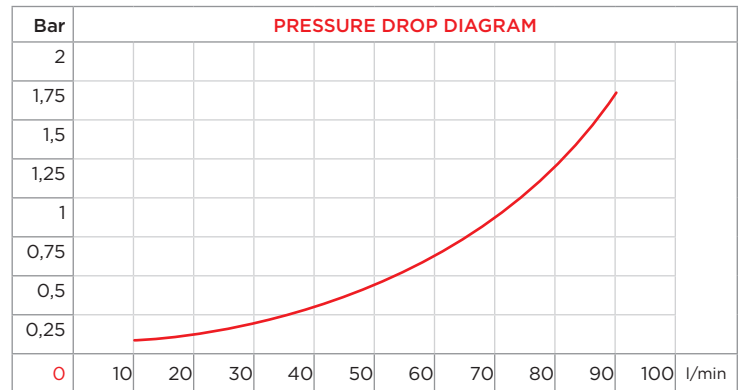
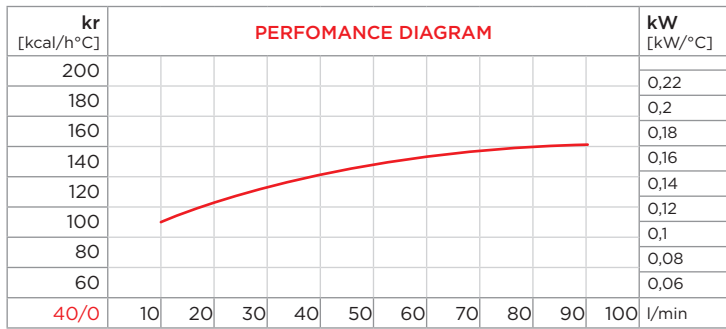

CORRECTION FACTOR							
cSt	22	30	46	68	100	150	220
f	0,6	1	1,5	2,3	3,5	5	7

PURCHASE CODES

APL 263 12/24V without thermo switch	3RL26312 / 3RL26324
APL 263 12/24V with thermo switch	3RL26312T247 / 3RL26324T247 3RL26312T260 / 3RL26324T260

SPARE PARTS

Thermo-switch 47-36 12V IP 67	1TRM47-36/12V
Thermo-switch 47-36 24V IP 67	1TRM47-36/24V
Thermo-switch 60-49 12V IP 67	1TRM60-49/12V
Thermo-switch 60-49 24V IP 67	1TRM60-49/24V
Cooling element	3RNL263
Frame	3CNAP260.1
12VDC Electric fan	1MCVA14AP7AC
24VDC Electric fan	1MCVA14BP7AC



- Dimensions and technical characteristics are not binding

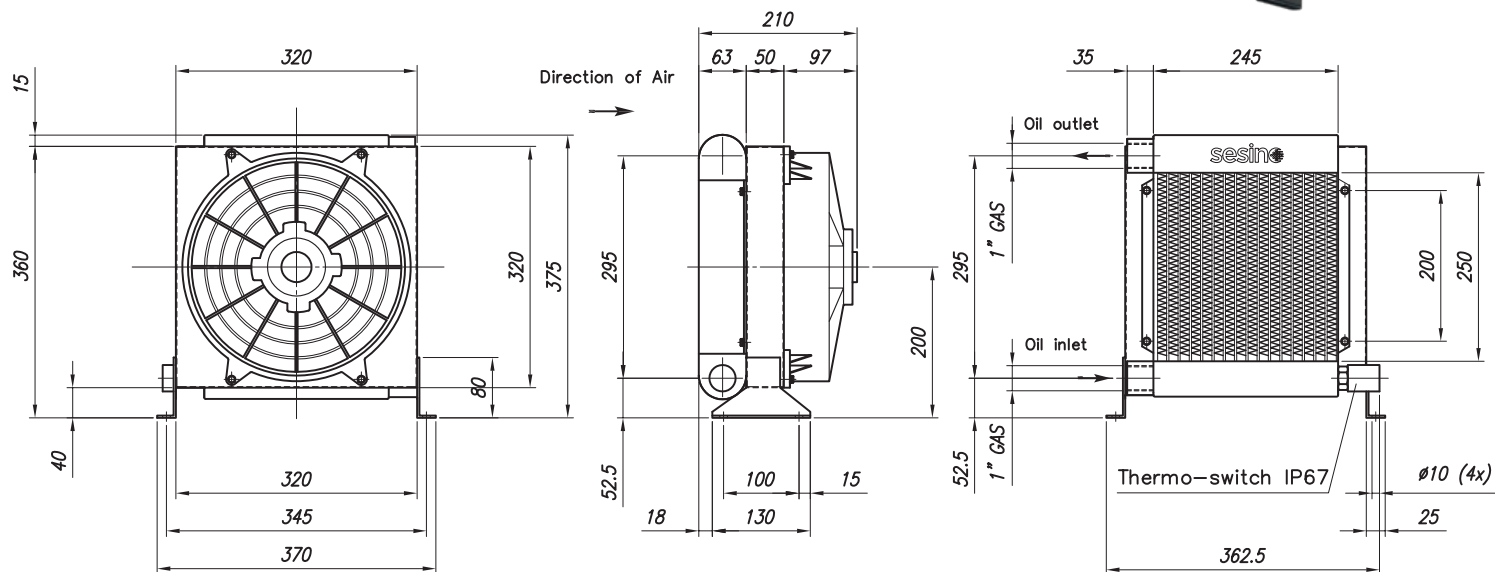

Static working pressure = 20 bar

Test pressure = 35 bar

OIL FLOW	VOLTAGE	POWER	CURRENT	AIR FLOW	ELECTRIC PROTECTION	NOISE LEV.	WEIGHT	CAPACITY	ø FAN
l/min	V	W	A	m ³ /h	IP	dB(A)	kg	lt.	mm
20-150	12	190	14,8	1.700	68	79	10	2	280
20-150	24	190	7,4	1.700	68	79	10	2	280

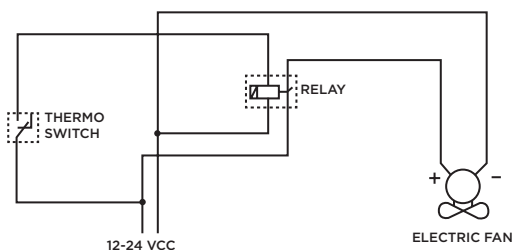
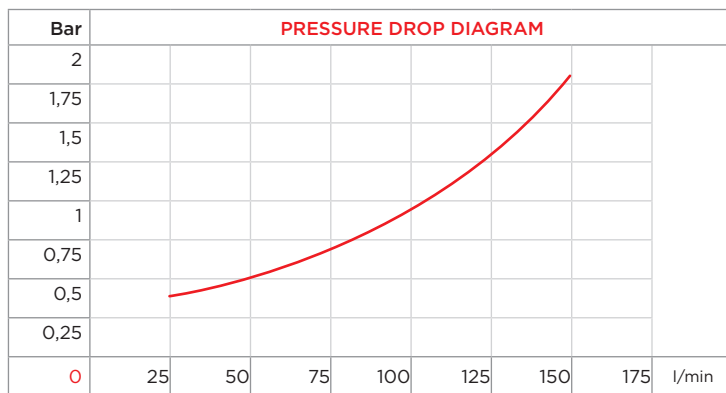
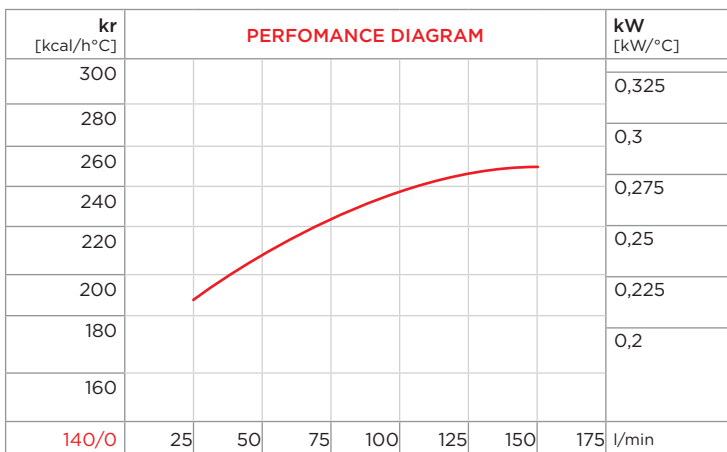

PURCHASE CODES

APL 300 12/24V without thermo switch	3RL30012 / 3RL30024
APL 300 12/24V with thermo switch	3RL30012T247 / 3RL30024T247 3RL30012T260 / 3RL30024T260

CORRECTION FACTOR

cSt	22	30	46	68	100	150	220
f	0,6	1	1,5	2,3	3,5	5	7

SPARE PARTS

Thermo-switch 47-36 12V IP 67	1TRM47-36/12V
Thermo-switch 47-36 24V IP 67	1TRM47-36/24V
Thermo-switch 60-49 12V IP 67	1TRM60-49/12V
Thermo-switch 60-49 24V IP 67	1TRM60-49/24V
Cooling element	3RNL300
Frame	3CNL300.1
12VDC Electric fan	1VNAPL30012C
24VDC Electric fan	1VNAPL30024C



- Dimensions and technical characteristics are not binding

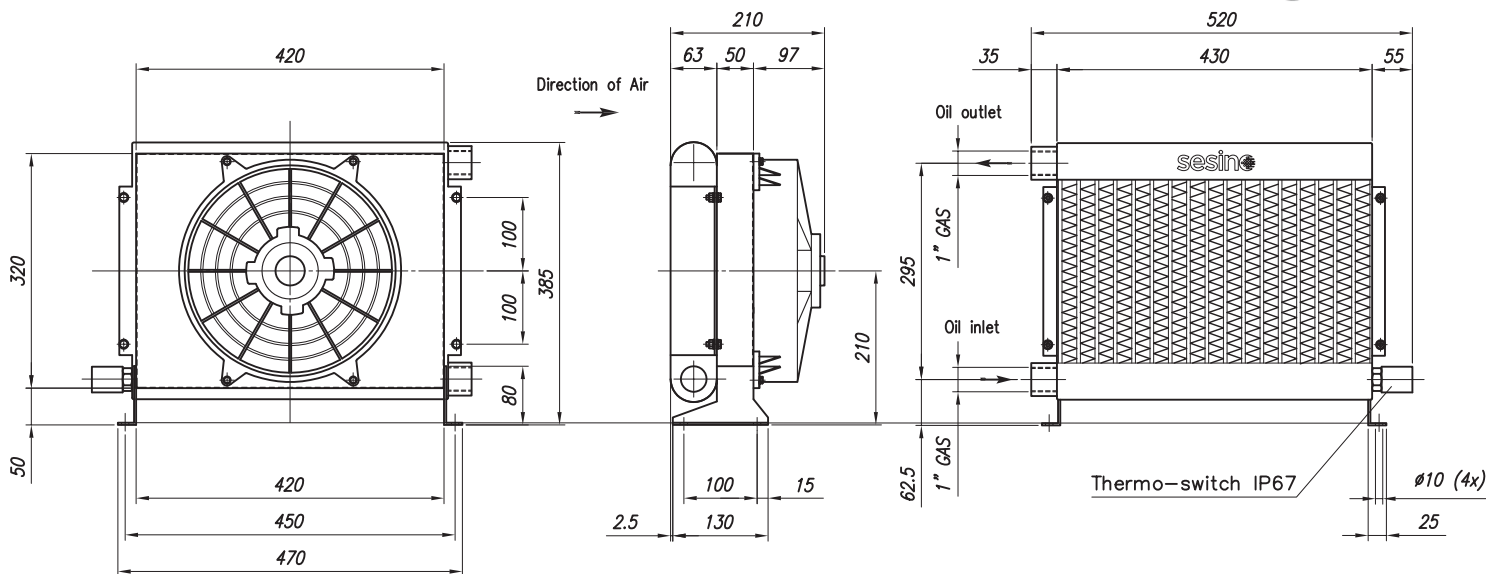

Static working pressure = 20 bar	Test pressure = 35 bar
----------------------------------	------------------------

OIL FLOW	VOLTAGE	POWER	CURRENT	AIR FLOW	ELECTRIC PROTECTION	NOISE LEV.	WEIGHT	CAPACITY	ø FAN
l/min	V	W	A	m ³ /h	IP	dB(A)	kg	lt.	mm
30-180	12	180	15,0	2.200	68	83	14	3,6	280
30-180	24	180	7,5	2.200	68	83	14	3,6	280

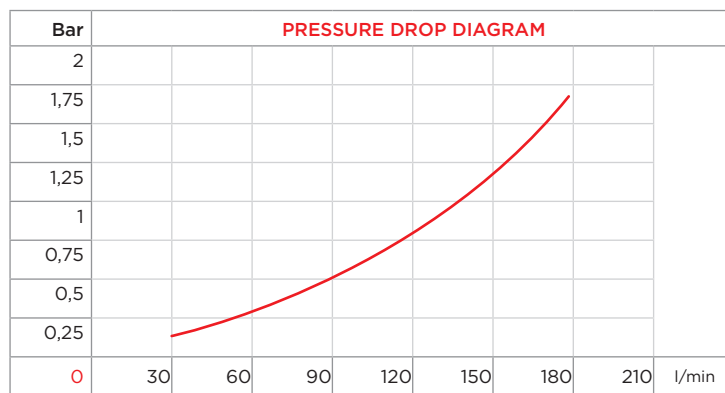
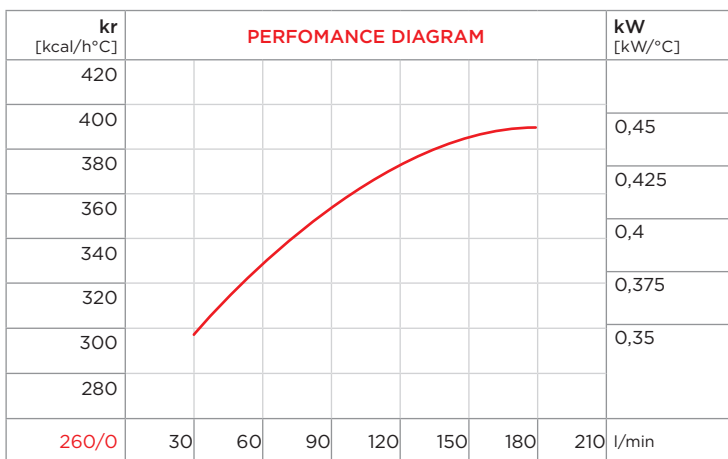

CORRECTION FACTOR							
cSt	22	30	46	68	100	150	220
f	0,6	1	1,5	2,3	3,5	5	7

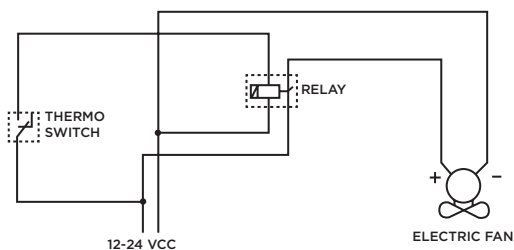

PURCHASE CODES

APL 300/2 12/24V without thermo switch	3RL30212 / 3RL30224
APL 300/2 12/24V with thermo switch	3RL30212T247 / 3RL30224T247 3RL30212T260 / 3RL30224T260

SPARE PARTS

Thermo-switch 47-36 12V IP 67	1TRM47-36/12V
Thermo-switch 47-36 24V IP 67	1TRM47-36/24V
Thermo-switch 60-49 12V IP 67	1TRM60-49/12V
Thermo-switch 60-49 24V IP 67	1TRM60-49/24V
Cooling element	3RNL302
Frame	3CNL302.1
12VDC Electric fan	1VNAPL30012C
24VDC Electric fan	1VNAPL30024C



- Dimensions and technical characteristics are not binding

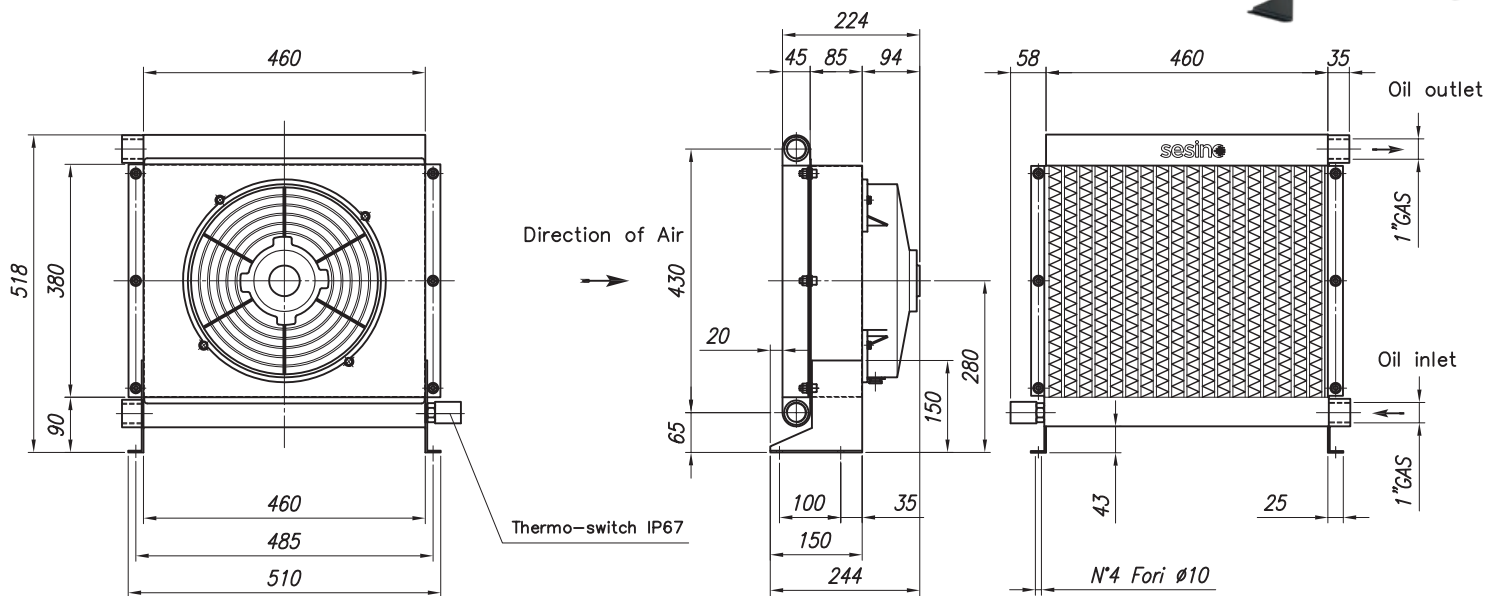

Static working pressure = 20 bar

Test pressure = 35 bar

OIL FLOW	VOLTAGE	POWER	CURRENT	AIR FLOW	ELECTRIC PROTECTION	NOISE LEV.	WEIGHT	CAPACITY	ø FAN
l/min	V	W	A	m ³ /h	IP	dB(A)	kg	lt.	mm
20-150	12	210	17	2.500	68	82	16	3,6	310
20-150	24	210	8,5	2.500	68	82	16	3,6	310

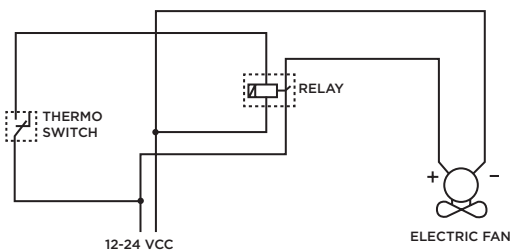
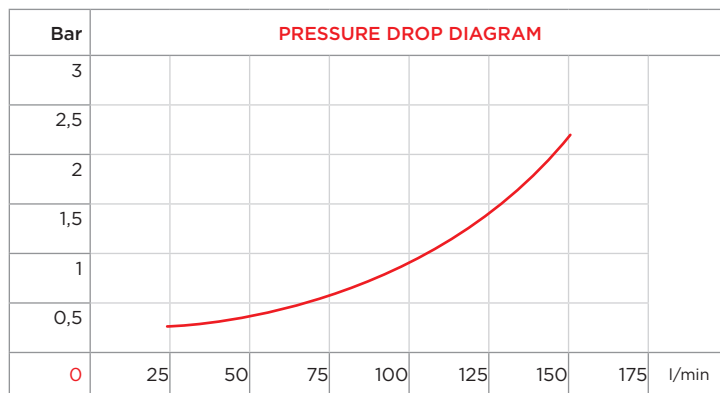
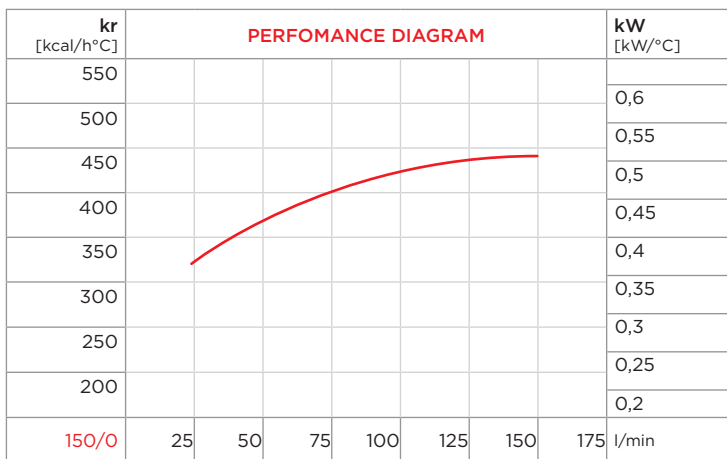

PURCHASE CODES

APL 430 12/24V without thermo switch	3RL43012 / 3RL43024
APL 430 12/24V with thermo switch	3RL43012T247 / 3RL43024T247 3RL43012T260 / 3RL43024T260

CORRECTION FACTOR

cSt	22	30	46	68	100	150	220
f	0,6	1	1,5	2,3	3,5	5	7

SPARE PARTS

Thermo-switch 47-36 12V IP 67	1TRM47-36/12V
Thermo-switch 47-36 24V IP 67	1TRM47-36/24V
Thermo-switch 60-49 12V IP 67	1TRM60-49/12V
Thermo-switch 60-49 24V IP 67	1TRM60-49/24V
Cooling element	3RNL430
Frame	1430LCNV
12VDC Electric fan	1VNAPL43012C
24VDC Electric fan	1VNAPL43024C



- Dimensions and technical characteristics are not binding

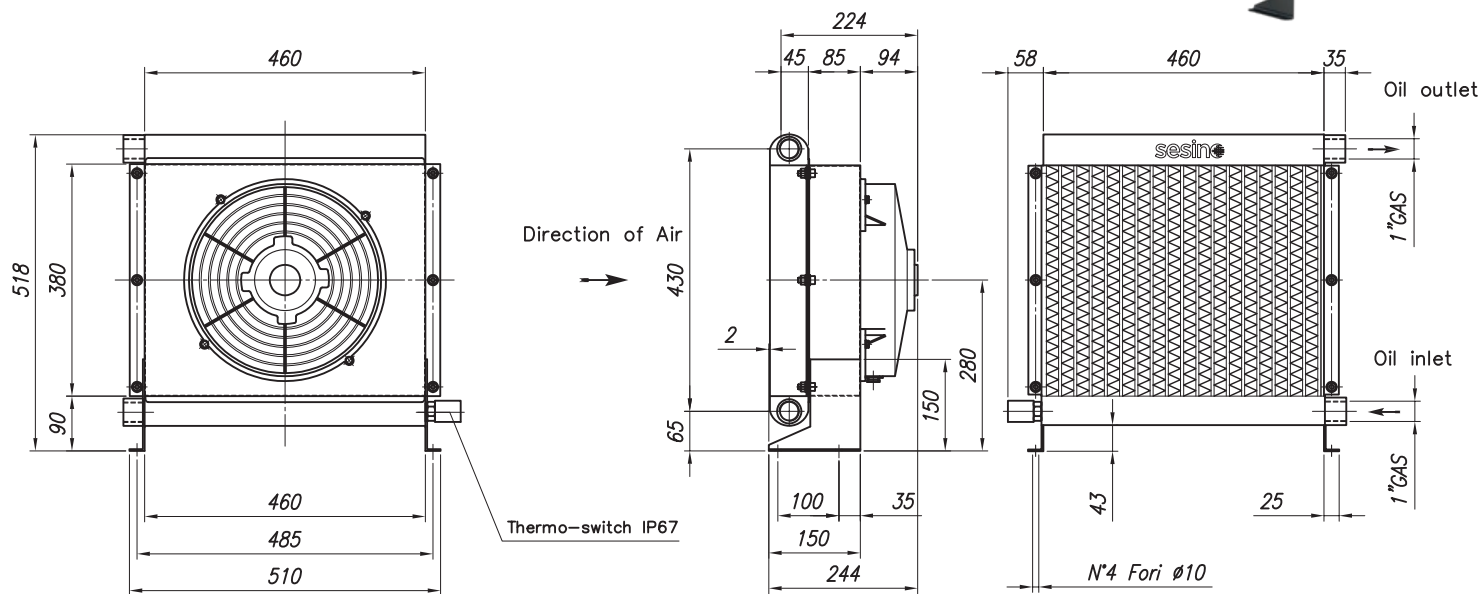

Static working pressure = 20 bar	Test pressure = 35 bar
----------------------------------	------------------------

OIL FLOW	VOLTAGE	POWER	CURRENT	AIR FLOW	ELECTRIC PROTECTION	NOISE LEV.	WEIGHT	CAPACITY	Ø FAN
l/min	V	W	A	m ³ /h	IP	dB(A)	kg	lt.	mm
30-200	12	210	17	2.400	68	82	20	5,5	310
30-200	24	210	8,5	2.400	68	82	20	5,5	310

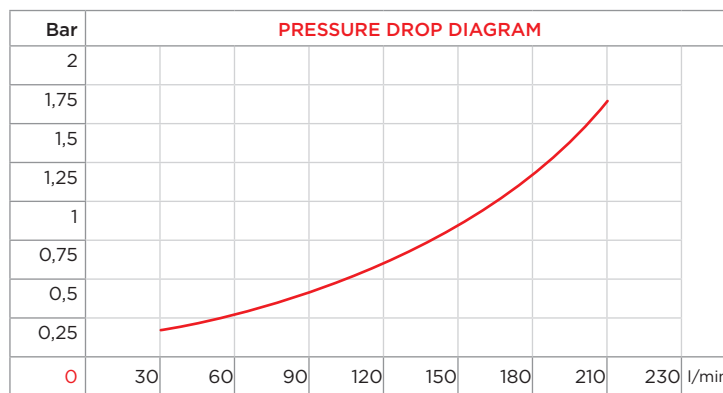
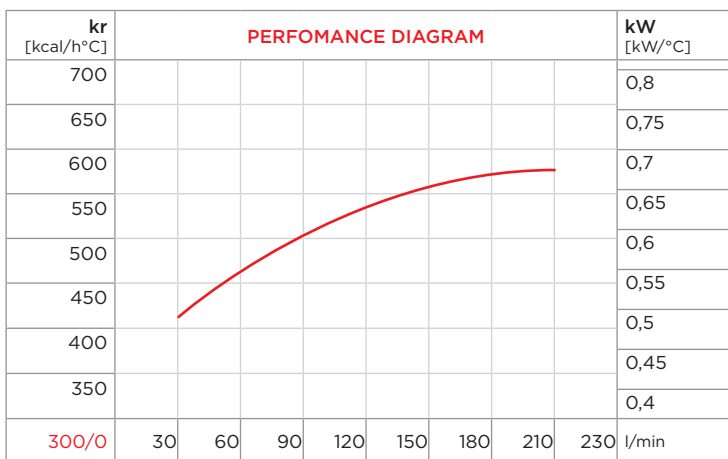

cSt	22	30	46	68	100	150	220
f	0,6	1	1,5	2,3	3,5	5	7

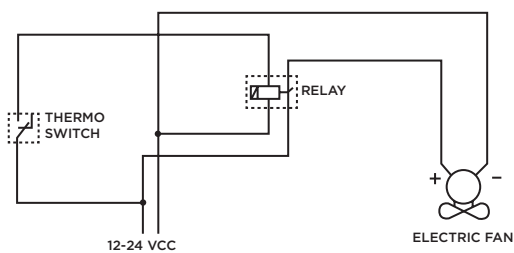

PURCHASE CODES

APL 430/2 12/24V without thermo switch	3RL43212 / 3RL43224
APL 430/2 12/24V with thermo switch	3RL43212T247 / 3RL43224T247 3RL43212T260 / 3RL43224T260

SPARE PARTS

Thermo-switch 47-36 12V IP 67	1TRM47-36/12V
Thermo-switch 47-36 24V IP 67	1TRM47-36/24V
Thermo-switch 60-49 12V IP 67	1TRM60-49/12V
Thermo-switch 60-49 24V IP 67	1TRM60-49/24V
Cooling element	3RNP432TP
Frame	1430LCNV
12VDC Electric fan	1VNAPL43012C
24VDC Electric fan	1VNAPL43024C



- Dimensions and technical characteristics are not binding

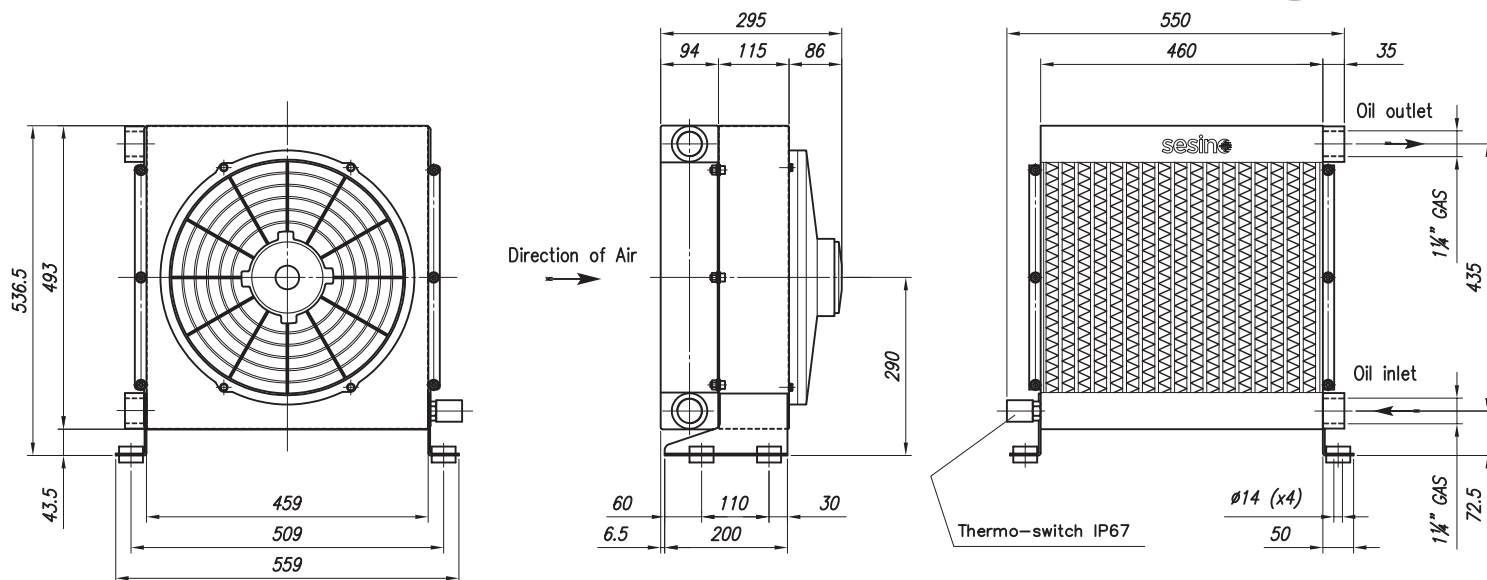

Static working pressure = 20 bar

Test pressure = 35 bar

OIL FLOW	VOLTAGE	POWER	CURRENT	AIR FLOW	ELECTRIC PROTECTION	NOISE LEV.	WEIGHT	CAPACITY	ø FAN
l/min	V	W	A	m ³ /h	IP	dB(A)	kg	lt.	mm
30-240	12	240	20	2.800	68	85	25	8	380
30-240	24	240	10	2.800	68	85	25	8	380

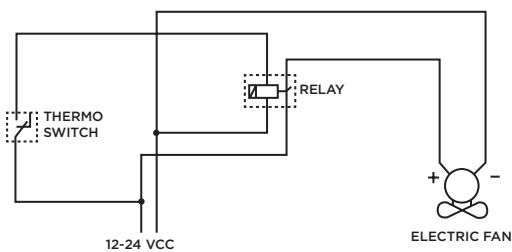
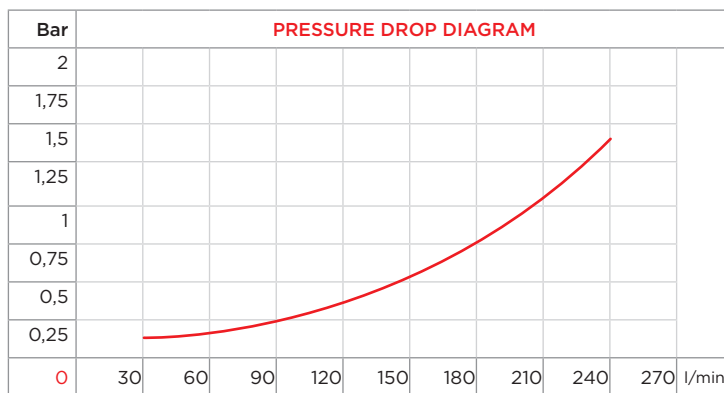
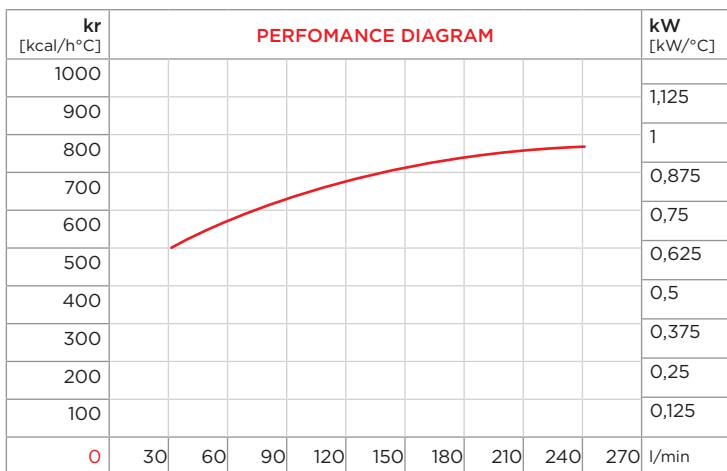

CORRECTION FACTOR							
cSt	22	30	46	68	100	150	220
f	0,6	1	1,5	2,3	3,5	5	7

SPARE PARTS

Thermo-switch 47-36 12V IP 67	1TRM47-36/12V
Thermo-switch 47-36 24V IP 67	1TRM47-36/24V
Thermo-switch 60-49 12V IP 67	1TRM60-49/12V
Thermo-switch 60-49 24V IP 67	1TRM60-49/24V
Cooling element	1RO99332
Frame	3CNL494.1
12VDC Electric fan	1MCVA18AP70AC
24VDC Electric fan	1VNAPL58024C

PURCHASE CODES

APL 494 12/24V without thermo switch	3RL49412 / 3RL49424
APL 494 12/24V with thermo switch	3RL49412T247 / 3RL49424T247 3RL49412T260 / 3RL49424T260



- Dimensions and technical characteristics are not binding

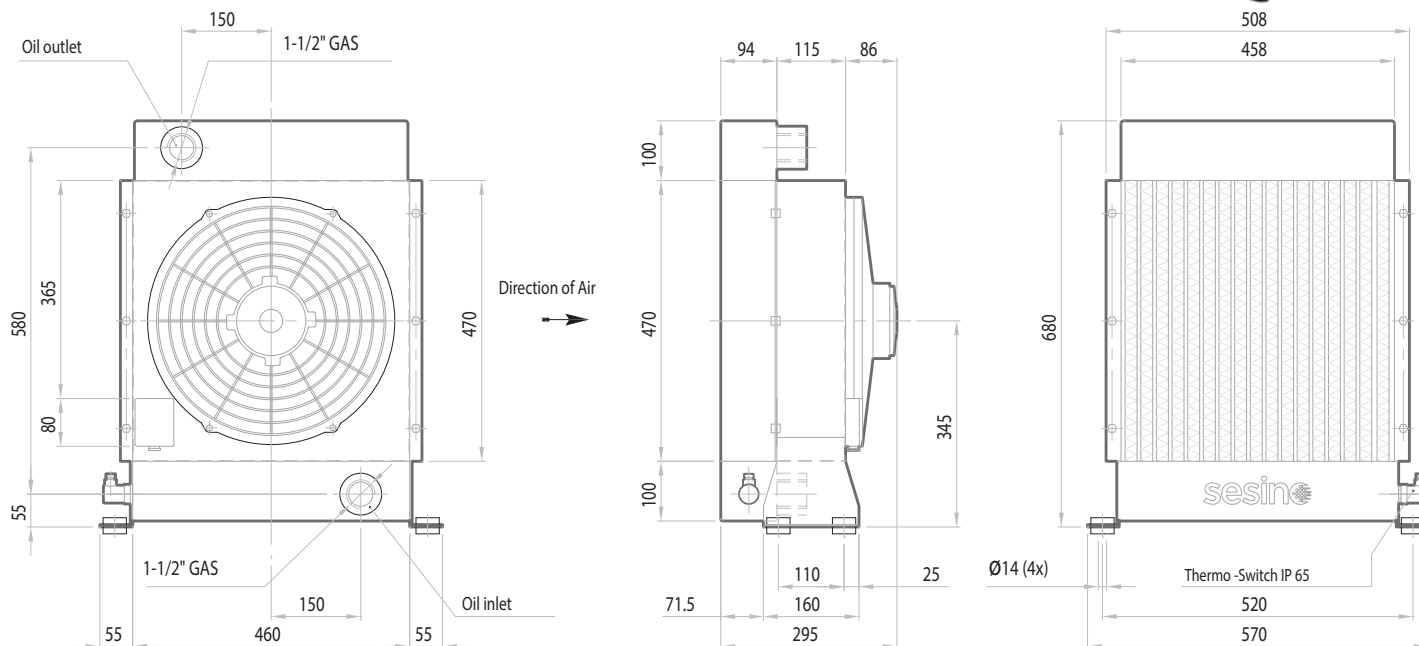

Static working pressure = 20 bar

Test pressure = 35 bar

OIL FLOW	VOLTAGE	POWER	CURRENT	AIR FLOW	ELECTRIC PROTECTION	NOISE LEV.	WEIGHT	CAPACITY	Ø FAN
l/min	V	W	A	m ³ /h	IP	dB(A)	kg	lt.	mm
50-250	12	240	20	2.900	68	85	33	11,5	380
50-250	24	240	10	2.900	68	85	33	11,5	380

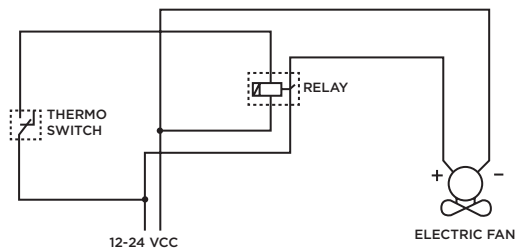
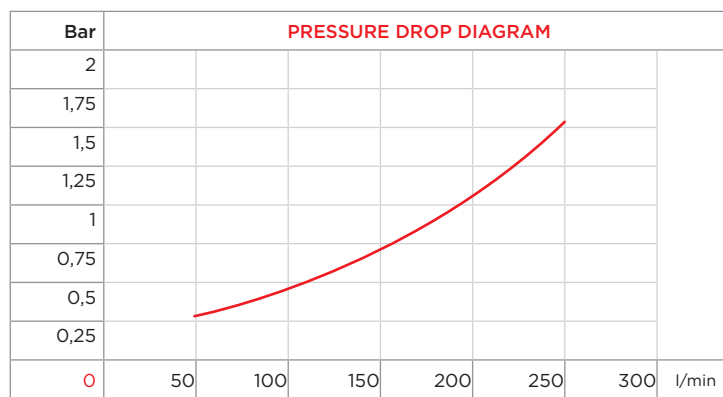
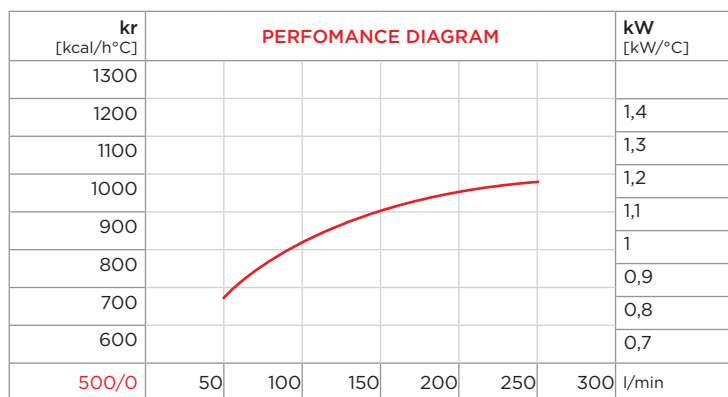

CORRECTION FACTOR							
cSt	22	30	46	68	100	150	220
f	0,6	1	1,5	2,3	3,5	5	7

PURCHASE CODES

APL 580 12/24V without thermo switch	3RL58012 / 3RL58024
APL 580 12/24V with thermo switch	3RL58012T247 / 3RL58024T247 3RL58012T260 / 3RL58024T260

SPARE PARTS

Thermo-switch 47-36 12V IP 67	1TRM47-36/12V
Thermo-switch 47-36 24V IP 67	1TRM47-36/24V
Thermo-switch 60-49 12V IP 67	1TRM60-49/12V
Thermo-switch 60-49 24V IP 67	1TRM60-49/24V
Cooling element	3RNL580
Frame	3CNL580.1
12VDC Electric fan	1MCVA18AP70AC
24VDC Electric fan	1VNAPL58024C



- Dimensions and technical characteristics are not binding

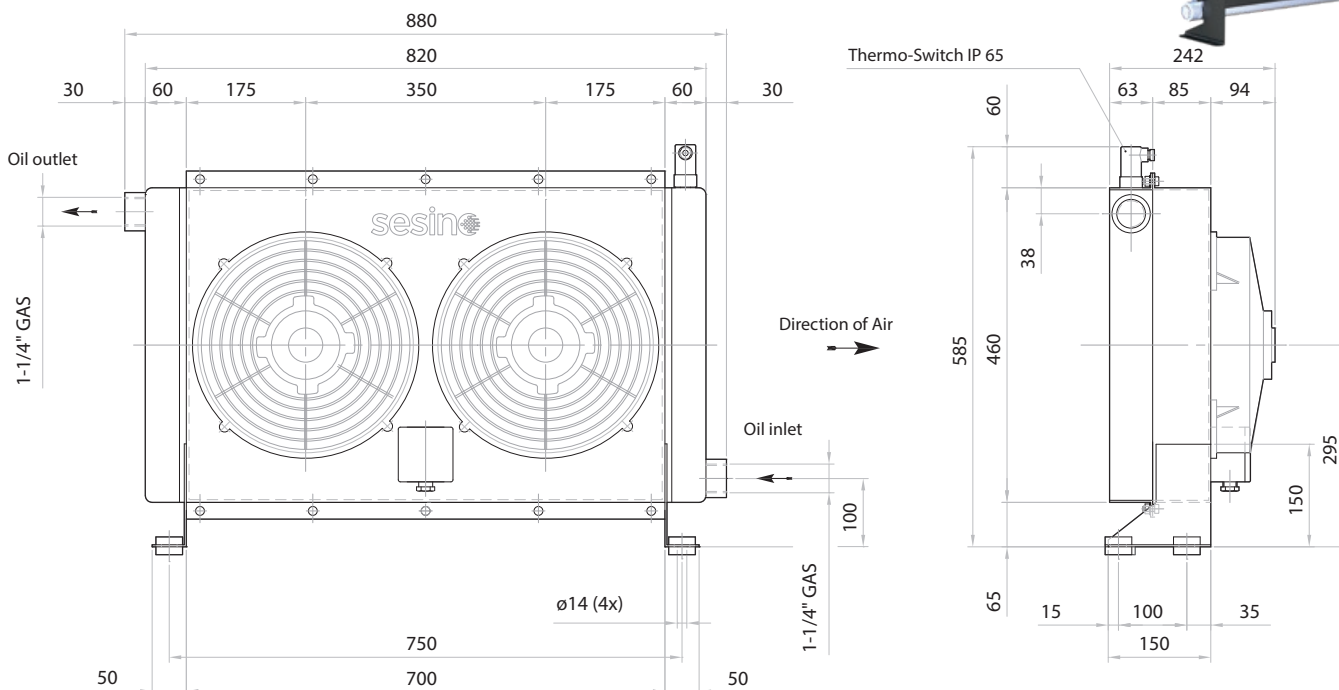

Static working pressure = 20 bar

Test pressure = 35 bar

OIL FLOW	VOLTAGE	POWER	CURRENT	AIR FLOW	ELECTRIC PROTECTION	NOISE LEV.	WEIGHT	CAPACITY	Ø FAN
l/min	V	W	A	m ³ /h	IP	dB(A)	kg	lt.	mm
30-240	12	420	34	4.800	68	85	40	8	310
30-240	24	420	17	4.800	68	85	40	8	310

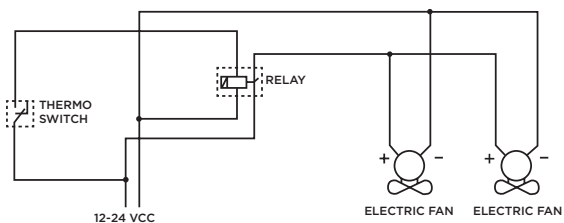
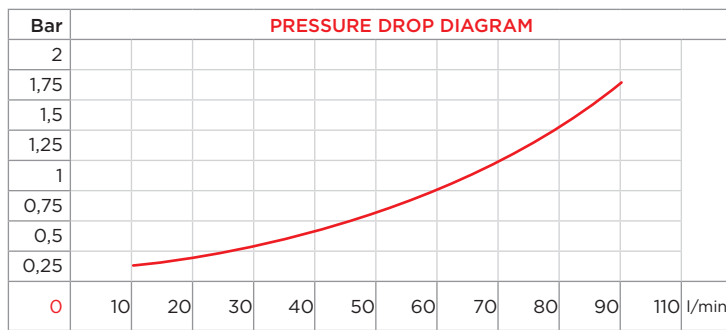
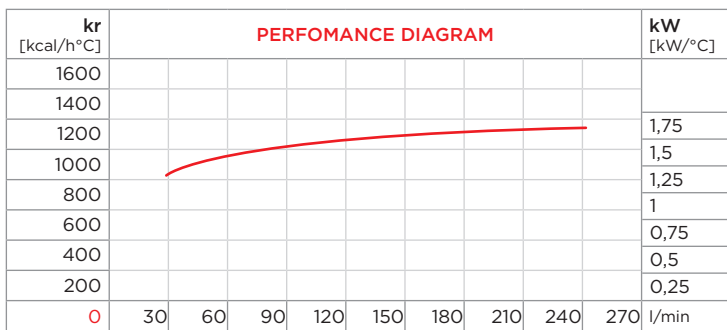

CORRECTION FACTOR							
cSt	22	30	46	68	100	150	220
f	0,6	1	1,5	2,3	3,5	5	7

SPARE PARTS

Thermo-switch 60-49 IP 65	1TRM60-49
Thermo-switch 47-36 IP 65	1TRM47-36
Electric junction box	1CSSDBOPLA
12VDC Relay	1RLCOPAT12
24VDC Relay	1RLCOPAT
Shock isolating mounting (4 pcs)	3KIT4135
Cooling element	1RO01341
Frame	3CNL2/463.1
12VDC Electric fan	1VNAPL43012C
24VDC Electric fan	1VNAPL43024C

PURCHASE CODES

APL 2/463 12/24V without thermo switch	3RL2/46312 / 3RL2/46324
APL 2/463 12/24V with thermo switch	3RL2/46312T247 / 3RL2/46324T247 3RL2/46312T260 / 3RL2/46324T260



- Dimensions and technical characteristics are not binding

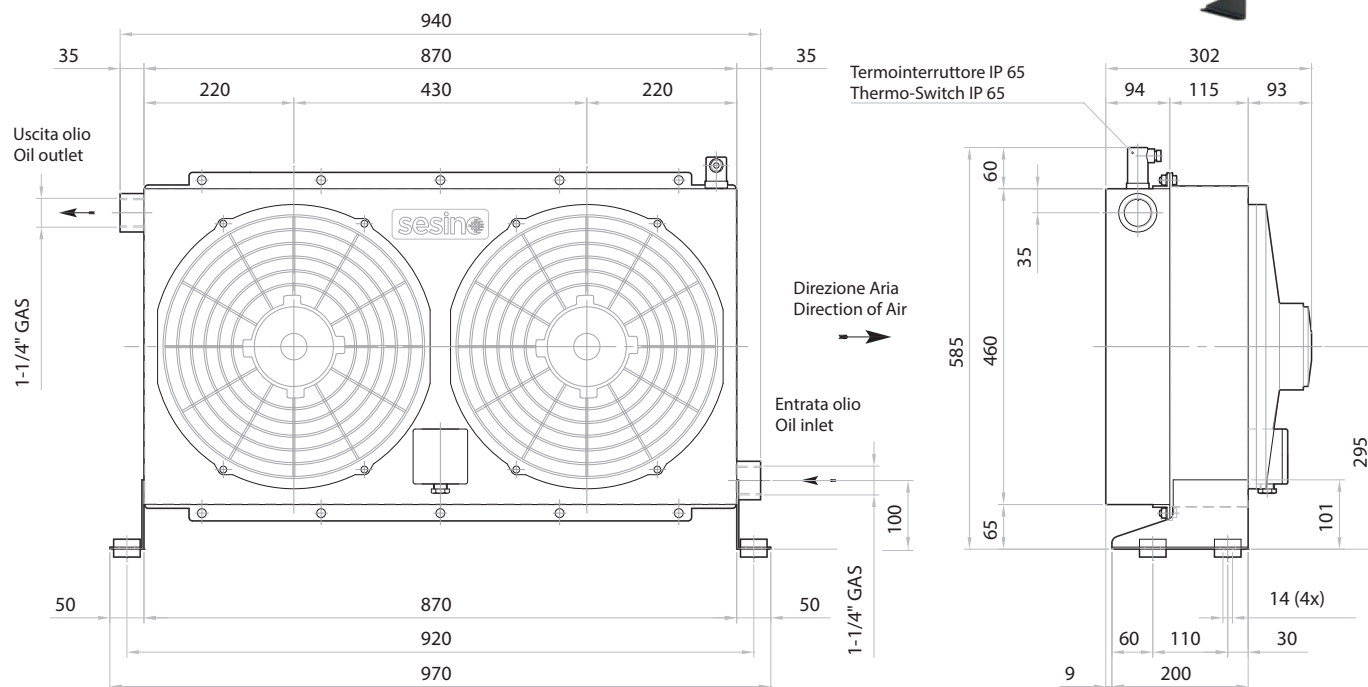

Static working pressure = 20 bar	Test pressure = 35 bar
----------------------------------	------------------------

OIL FLOW	VOLTAGE	POWER	CURRENT	AIR FLOW	ELECTRIC PROTECTION	NOISE LEV.	WEIGHT	CAPACITY	ø FAN
l/min	V	W	A	m ³ /h	IP	dB(A)	kg	lt.	mm
30-240	12	480	40	5.600	68	88	50	16	380
30-240	24	480	20	5.600	68	88	50	16	380

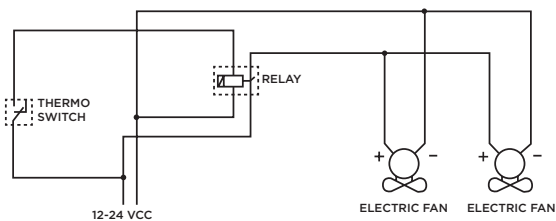
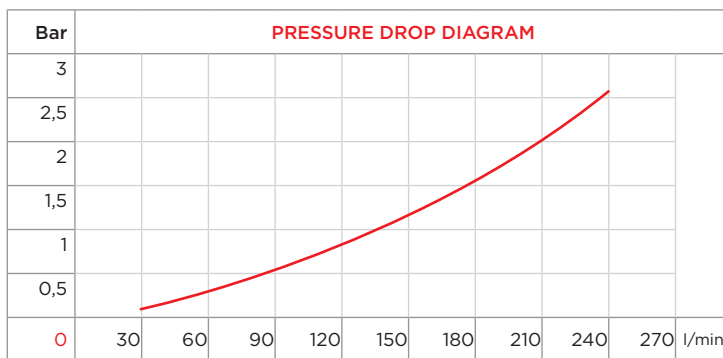
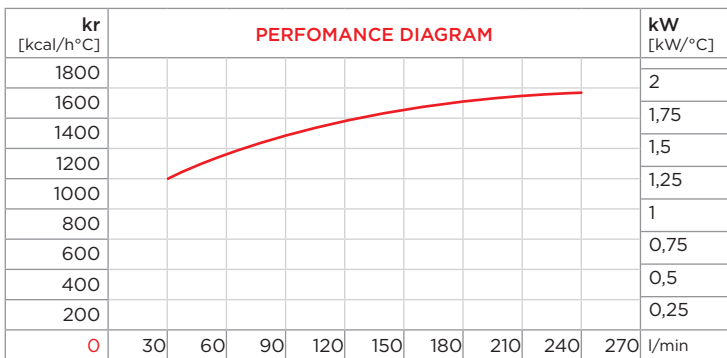

CORRECTION FACTOR							
cSt	22	30	46	68	100	150	220
f	0,6	1	1,5	2,3	3,5	5	7

PURCHASE CODES

APL 2/494 12/24V without thermo switch	3RL2/49412 / 3RL2/49424
APL 2/494 12/24V with thermo switch	3RL2/49412T247 / 3RL2/49424T247 3RL2/49412T260 / 3RL2/49424T260

SPARE PARTS

Thermo-switch 60-49 IP 65	1TRM60-49
Thermo-switch 47-36 IP 65	1TRM47-36
Electric junction box	1CSSDBOPLA
12VDC Relay	1RLCOPAT12
24VDC Relay	1RLCOPAT
Shock isolating mounting (4 pcs)	3KIT4135
Cooling element	1RO01342
Frame	3CNL2/494.1
12VDC Electric fan	1MCVA18AP70C
24VDC Electric fan	1VNAPL58024C



- Dimensions and technical characteristics are not binding

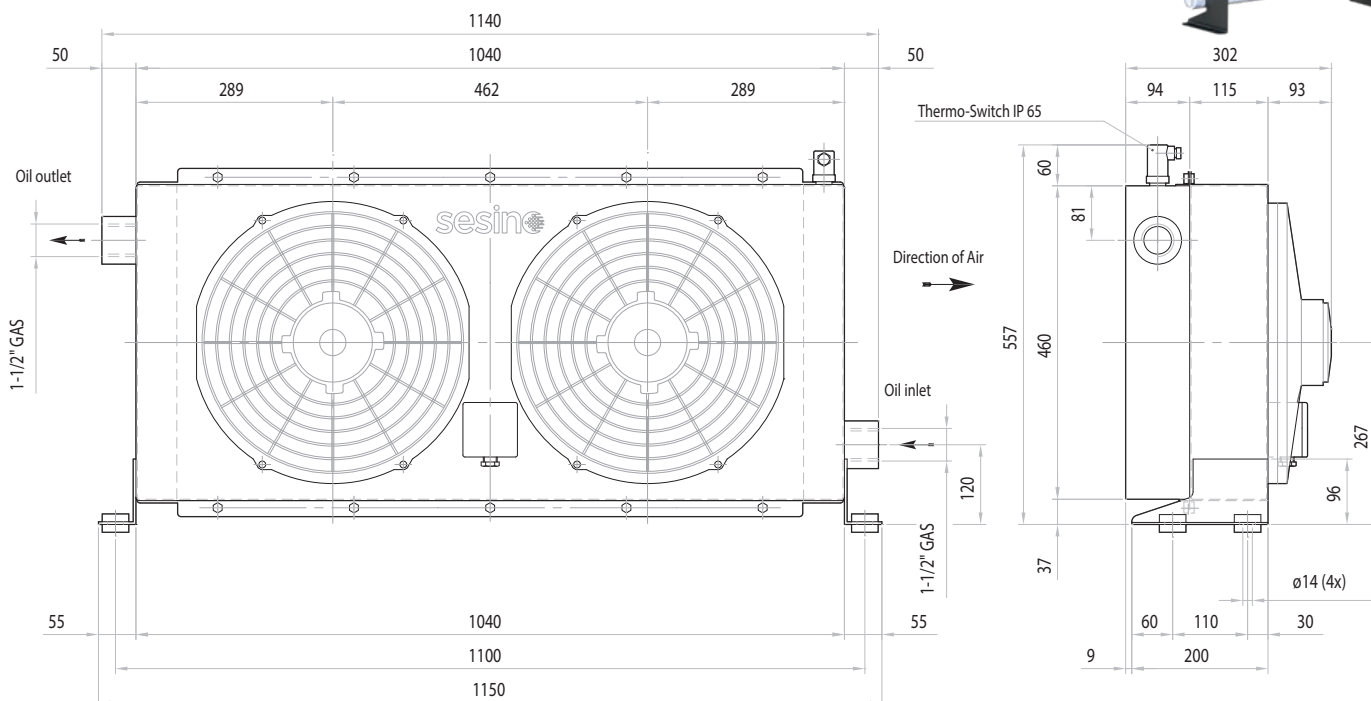

Static working pressure = 20 bar	Test pressure = 35 bar
----------------------------------	------------------------

OIL FLOW	VOLTAGE	POWER	CURRENT	AIR FLOW	ELECTRIC PROTECTION	NOISE LEV.	WEIGHT	CAPACITY	ø FAN
l/min	V	W	A	m ³ /h	IP	dB(A)	kg	lt.	mm
30-350	12	480	40	5.800	68	88	60	23	380
30-350	24	480	20	5.800	68	88	60	23	380

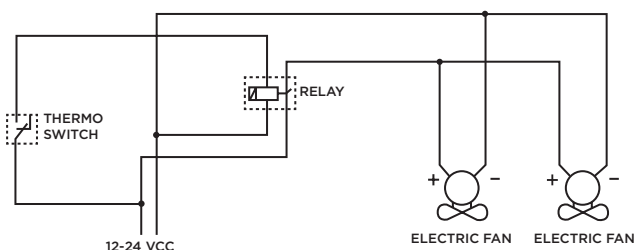
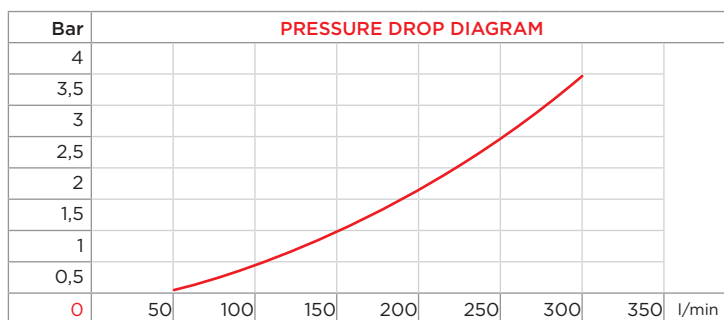
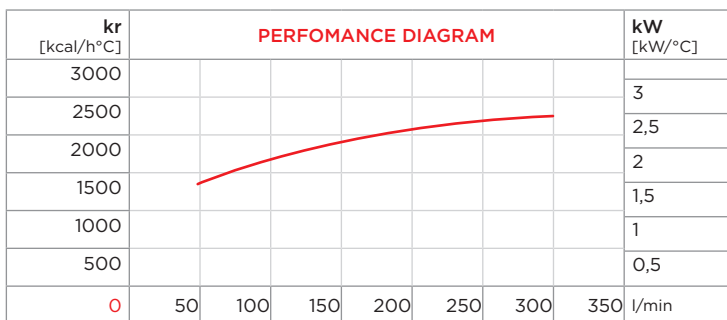

cSt	22	30	46	68	100	150	220
f	0,6	1	1,5	2,3	3,5	5	7

SPARE PARTS

Thermo-switch 60-49 IP 65	1TRM60-49
Thermo-switch 47-36 IP 65	1TRM47-36
Electric junction box	1CSSDBOPLA
12VDC Relay	1RLCOPAT12
24VDC Relay	1RLCOPAT
Shock isolating mounting (4 pcs)	3KIT4135
Cooling element	1RO00336
Frame	3CNL2/580.1
12VDC Electric fan	1MCVA18AP70AC
24VDC Electric fan	1VNAPL58024C

PURCHASE CODES

APL 2/580 12/24V without thermo switch	3RL2/58012 / 3RL2/58024
APL 2/580 12/24V with thermo switch	3RL2/58012T247 / 3RL2/58024T247 3RL2/58012T260 / 3RL2/58024T260





AIR-OIL HEAT EXCHANGERS ELRO/91261 SCAMBIATORI PER MESCOLATORI DI CALCESTRUZZO

This is a special type of heat exchanger with incorporated tank and filter. It is suitable for the cooling of hydrostatics transmissions in off-line circuits, above all on concrete mixers, and allows simplifying the hydraulic system and reducing in this way its cost.

Besides the standard aluminum cooling element with DC fan 12 or 24V, this exchanger is equipped with tank with capacity 18 l. with suction filter, level gauge, condensate drainage system and a thermo switch with a fixed calibration of 65°C.

The flow rates shown in the tables are the ones recommended for the exchanger proper working.

Going down the lowest flow rate, the low oil speed causes a great efficiency decrease, whereas a flow rate, which is superior to the maximum indicated, causes great pressure losses and does not considerably increase the thermal performance.

The efficiency curves show the specific exchange capacity in kcal/h°C or in kW/°C according to the different oil rates. To calculate the heat quantity the different exchangers are able to dissipate it is enough to multiply such capacity by the difference between the requested oil temperature and the summer room temperature.

As these exchangers are assembled on machines working in the open air, the steel parts are subjected to a chemical treatment, which prevents from rust. On this treatment, the customer can use each kind of painting.

Questo è un particolare tipo di scambiatore con serbatoio e filtro incorporato. È indicato per il raffreddamento di trasmissioni idrostatiche in circuito chiuso, soprattutto su mescolatori di calcestruzzo e consente una notevole semplificazione dell'impianto idraulico e una notevole riduzione di costi dello stesso.

Oltre al normale pacco radiante in alluminio con ventilatore a corrente continua 12 o 24 V, questo scambiatore è munito di serbatoio avente capacità 18 litri con filtro in aspirazione, livello visivo, scarico condensa e termostato fisso taratura 65°C.

Le portate olio indicate in tabella sono quelle consigliate per il buon funzionamento dello scambiatore: andando al di sotto della portata minima la bassa velocità dell'olio causa un forte calo di rendimento, mentre con una portata superiore alla massima aumentano le perdite di carico senza che il rendimento migliori in maniera apprezzabile.

La curva di rendimento fornisce la potenzialità di scambio specifica in kcal/h°C o in KW/°C in funzione delle diverse portate olio; per calcolare la quantità di calore che lo scambiatore è in grado di disperdere è sufficiente moltiplicare tale potenzialità per la differenza tra la temperatura dell'olio desiderata e quella dell'aria ambiente estiva. Poiché questi scambiatori sono installati su macchine che lavorano all'esterno, esposte quindi alle intemperie, le parti in lamiera di acciaio vengono sottoposte a un trattamento chimico particolare che inibisce la formazione di ruggine; su tale trattamento può essere effettuato qualsiasi tipo di verniciatura da parte del cliente.

- Dimensions and technical characteristics are not binding

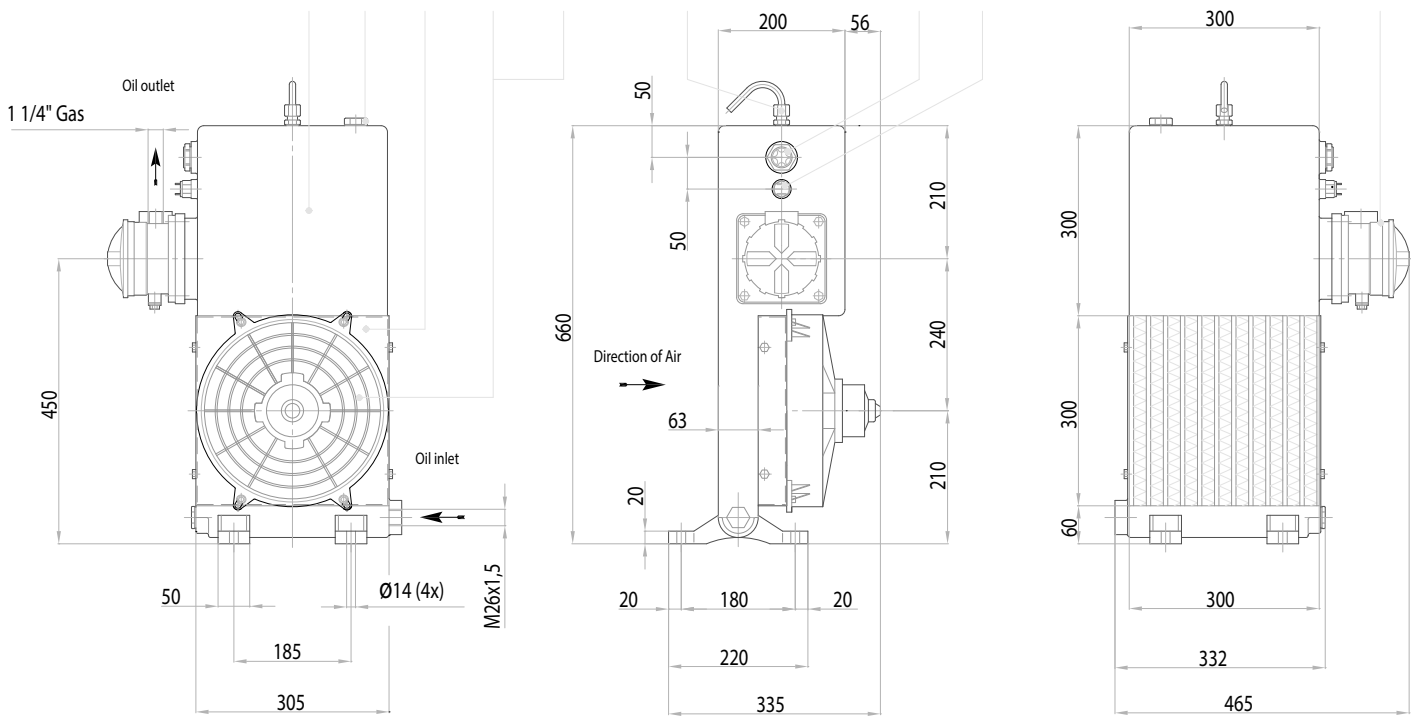

OIL FLOW	CAPACITY	VOLTAGE	POWER	CURRENT	AIR FLOW	PROTECTION	NOISE LEVEL	WEIGHT	ø FAN
l/min	l	V	W	A	m ³ /h	IP	dB(A)	kg	mm
upon request only		12	180	15	1.600	68	74	18	280
5-60	18	24	180	7,5	1.600	68	74	18	280

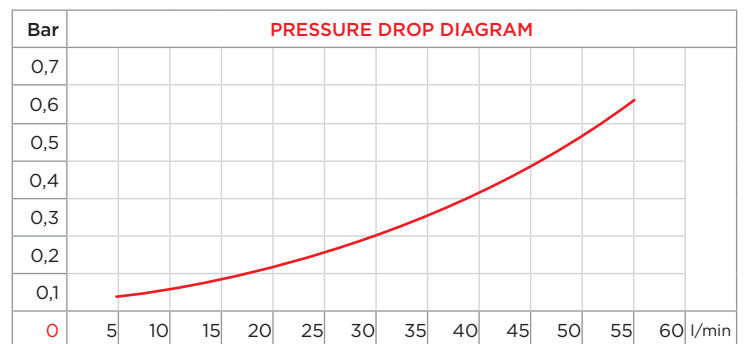
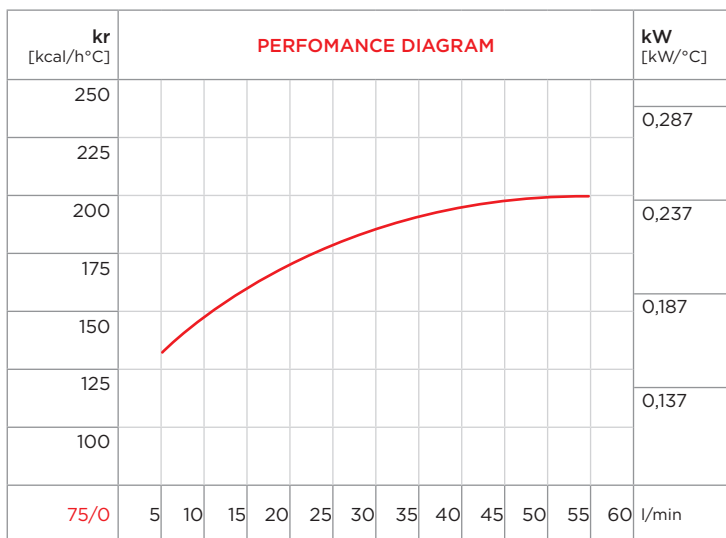

CORRECTION FACTOR

cSt	22	30	46	68	100	150	220
f	0,6	1	1,5	2,3	3,5	5	7

PURCHASE CODES

ELRO 91261 with filter	3REO91261C
ELRO 91261 without filter	3REO91261

SPARE PARTS

Frame	3CNEO91261.1
Cooling element	3RNEO91261
Electric fan	1VNEO91261
Inlet plug	1T TC6
Level gauge	1LIVTLA56
Thermo-switch 55-44 °C	1TRM55-44
Thermo-switch 65-54 °C	1TRM65-54
Oil Filter	1FTREO91261
Breather pipe	3TBSFEO91261.1
Filter element	1CRTEO91261

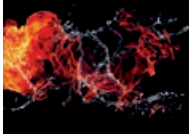

ASSEMBLING AND MAINTENANCE INSTRUCTIONS OF THE AIR-OIL HEAT EXCHANGERS

Assembling

The exchanger must be assembled so that the airflow is not obstructed both in the inlet and in the outlet of the cooling element. To obtain a better efficiency it is important to avoid any recycling of warm air between inlet and aspiration. In case of long downtime at cold temperatures, the oil temperature becomes very low and its viscosity increases.

When the machine starts again, the loss of pressure can become superior to the maximum allowable pressure; in this case, the exchanger must be equipped with a by-pass valve with proper calibration. Sesino Air-oil heat exchangers are generally installed in the return circuit.

It is also possible to realize a separate circuit with an autonomous pump and this is recommended when the oil flows at the outlet are variable. In this way, it is possible to obtain a better heating performance. Oil must flow in from the bottom.

The inlet and outlet fittings must be connected without any tension and must not transmit any vibration to the exchanger. The pressure peaks must never exceed the maximum allowable dynamic pressure of the exchanger.

Operating

As first check that the tension correspond to the one on the heat exchanger plate.

The oil temperature can be adjusted by stopping or starting the electric fan and to do that, the thermostat must be adjusted on the required temperature.

If there is a need of a continuous working of the fan, turn the thermo switch knob on the minimum.

In the hydraulic systems, some pressure peaks can occur; they could approach or exceed the maximum allowable pressure of the exchanger. These pulsations move inside the oil at the sound velocity and therefore they cannot be gauged with standard manometers, but only with a proper electronical instrumentation.

If these peaks exceed the value of 20 bar, it is necessary to supply the exchanger with a self-contained pump.

The maximum allowable static pressure is of 35 bar.

MAINTENANCE

Oil side cleaning

For this kind of cleaning, the heat exchanger must be disconnected. In order to remove the dirt, let a detergent circulate from 10 to 30 minutes, then proceed removing the detergent with compressed air. Dopo questa operazione il prodotto resta all'interno e bisognerà quindi procedere alla sua espulsione tramite aria compressa.

Air side cleaning

It can be carried with compressed air or water. The direction of the stream must be parallel to the fins to avoid damaging them. It is possible to use some detergent but only if it does not deteriorate the aluminum. If the dirt consists of oil or grease, it is possible to use a stream of steam or hot water. During the cleaning the electric motor has to be adequately protected.

ISTRUZIONI DI MONTAGGIO, FUNZIONAMENTO E MANUTENZIONE DEGLI SCAMBIATORI ARIA-OLIO SESINO

Montaggio

Lo scambiatore deve essere installato in modo che l'aria non sia ostacolata nel suo fluire sia in aspirazione che all'uscita del pacco radiante. Per una resa termica ottimale bisogna evitare qualsiasi riciclaggio d'aria calda tra uscita ed aspirazione.

In caso di fermo macchina prolungato a temperature rigide invernali, la temperatura dell'olio diventa molto bassa e quindi aumenta molto la sua viscosità. Alla rimessa in marcia, la perdita di carico può diventare superiore alla massima pressione ammissibile; in questo caso bisogna dotare lo scambiatore di una valvola di by-pass di taratura appropriata.

Gli scambiatori aria-olio Sesino SpA sono generalmente installati sul circuito di ritorno; è possibile anche realizzare un circuito separato con una pompa autonoma e ciò è consigliabile nel caso in cui le portate allo scarico siano molto variabili; ciò facendo si ottiene anche un miglioramento di resa termica.

L'entrata dell'olio deve avvenire preferibilmente dal basso. I raccordi di entrata ed uscita olio devono essere collegati senza tensioni e non dovranno trasmettere alcuna vibrazione allo scambiatore. Per quanto riguarda i colpi di pressione, essi non devono mai superare la pressione dinamica massima ammessa dallo scambiatore.

Funzionamento

Si deve innanzi tutto verificare che la tensione e la frequenza di alimentazione corrisponda a quella indicata sulla targhetta.

La temperatura dell'olio può essere regolata mediante l'interruzione o l'azionamento dell'elettroventola; per fare ciò viene utilizzato il termostato impostandolo sulla temperatura desiderata.

Nel caso si desiderasse un funzionamento continuo del ventilatore, è sufficiente ruotare la manopola del termostato sul valore minimo.

Nei sistemi idraulici possono verificarsi dei picchi di pressione che possono avvicinarsi o superare la pressione massima ammissibile dello scambiatore. Poiché tali pulsazioni viaggiano nell'olio alla velocità del suono, esse non sono misurabili con normali manometri, ma solo con un'adatta strumentazione elettronica.

Nel caso in cui questi picchi superino il valore di 20 bar, è indispensabile alimentare lo scambiatore con una pompa autonoma.

La pressione statica massima ammessa è di 35 bar.

MANUTENZIONE

Pulizia lato olio.

Per tale tipo di pulizia lo scambiatore deve essere smontato. Lo sporco potrà essere eliminato con la circolazione di un prodotto detergente. La durata di questa operazione dipende naturalmente dal grado di sporco; può variare da 10 a 30 minuti. Dopo questa operazione il prodotto resta all'interno e bisognerà quindi procedere alla sua espulsione tramite aria compressa.

Pulizia lato aria.

Essa potrà essere eseguita mediante aria compressa o acqua. La direzione del getto dovrà essere parallela alle alette per non danneggiarle. Il risultato potrà essere migliore con l'aggiunta di un prodotto detergente, ma bisogna essere certi che esso non intacchi l'alluminio. Se l'accumulo di sporco è causato da olio o da grasso, la pulizia potrà essere effettuata con un getto di vapore o di acqua calda. Durante le operazioni di pulizia il motore elettrico dovrà essere convenientemente protetto.

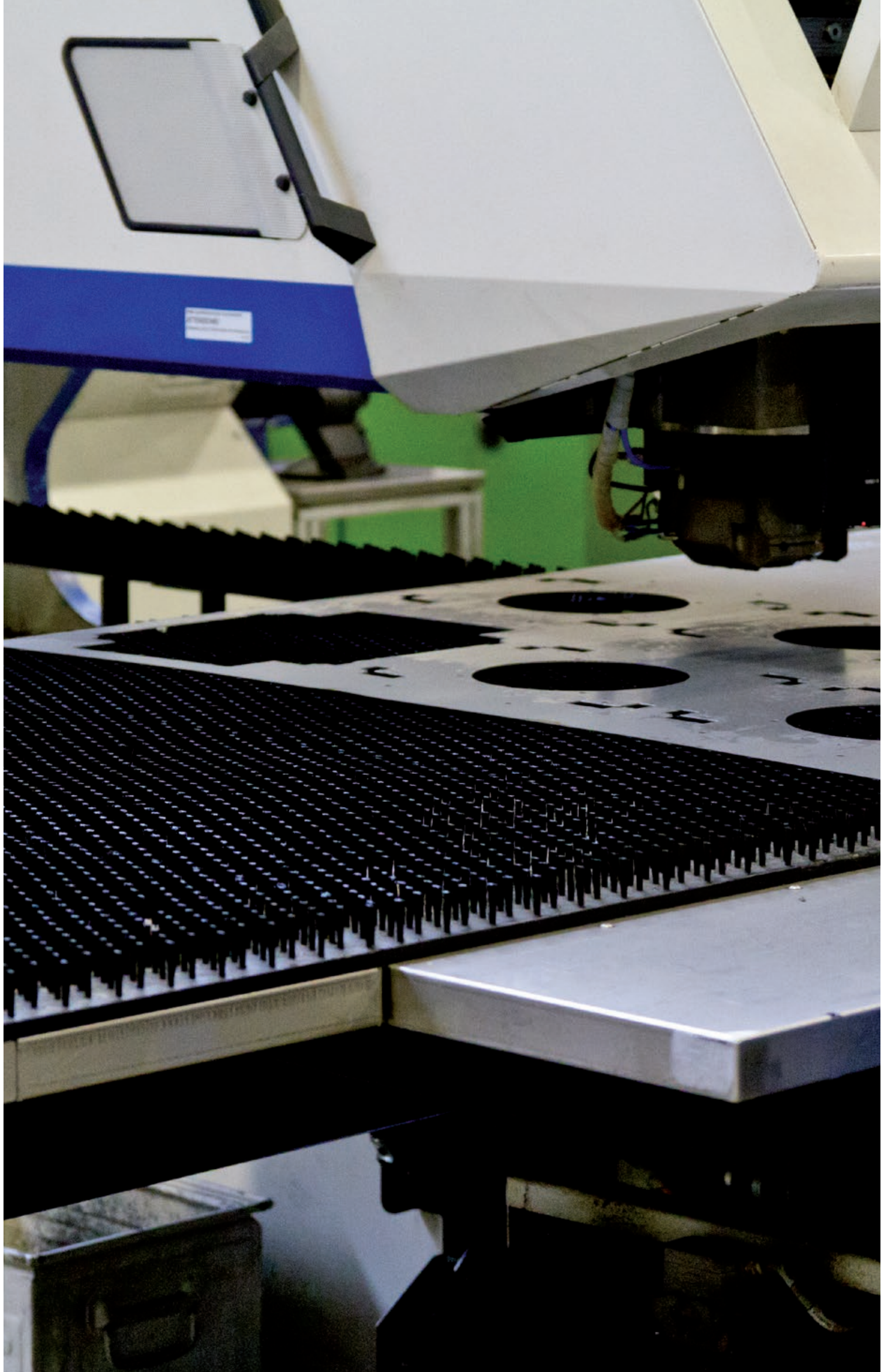

SELF CONTAINED COOLING UNIT

UNITÀ DI RAFFREDDAMENTO A CORRENTE ALTERNATA SERIE RAS



There are some applications where, because of the presence of high pressure peaks or extremely variable flow rates that can compromise the exchanger efficiency, it is not recommended to use a simple air-oil heat exchanger.

In such cases it is useful to feed the air-oil exchanger with an off-line pump, to make it independent from the primary oleo hydraulic plant. To satisfy this request, we have designed and realized the **self-contained cooling units type RAS**.

These exchangers consist of an air-oil heat exchanger and a double shaft electric motor that sets on an oil gear pump and a cooling fan. Maximum allowable working pressure: 10 bar.

In order to make the assembling easier, the electric connection is carried through an electric junction box fixed on the frame of the cooling unit.

Upon request, we can supply the unit with an adjustable thermo switch with a thermo switch probe to be placed into the tank to cool.

Always upon request, we can supply an oil filter to connect to the pump in suction.

The efficiency diagrams show the heat quantity each cooling unit is able to dissipate kW according to the difference between the requested oil temperature and the summer room temperature.

In alcune applicazioni non è possibile o consigliabile utilizzare un semplice scambiatore di calore aria-olio a causa della presenza di colpi d'ariete di elevata intensità o di portate olio estremamente variabili, tali da pregiudicare la resa termica dello scambiatore.

*In questi casi è utile alimentare lo scambiatore con una pompa off-line per renderlo indipendente dall'impianto oleoidraulico primario. Per soddisfare questa richiesta abbiamo realizzato le **Unità di Raffreddamento RAS**.*

Esse sono composte da uno scambiatore aria-olio e da un unico motore elettrico bialbero che aziona una pompa di circolazione olio a ingranaggi e una ventola di raffreddamento.

La pressione massima di funzionamento ammessa dello scambiatore è di 10 bar.

Per agevolare il montaggio, il collegamento elettrico viene effettuato tramite una cassetta di derivazione fissata esternamente sul telaio dell'Unità di Raffreddamento.

Su richiesta queste unità possono essere completate con un termostato elettronico regolabile munito di sonda da inserire all'interno del serbatoio da raffreddare.

Sempre su richiesta può essere fornito anche un filtro olio da collegare in aspirazione alla pompa.

I diagrammi di rendimento indicati qui di seguito, forniscono la quantità di calore che ogni Unità di Raffreddamento è in grado di dissipare in kW in funzione della differenza tra la temperatura dell'olio desiderata e la massima temperatura ambiente estiva.

RAS 1000

SELF CONTAINED COOLING UNIT
UNITÀ DI RAFFREDDAMENTO A CORRENTE ALTERNATA SERIE RAS



- Dimensions and technical characteristics are not binding

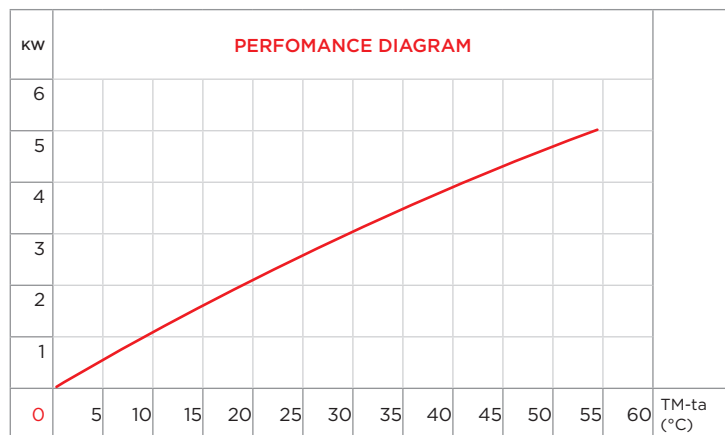
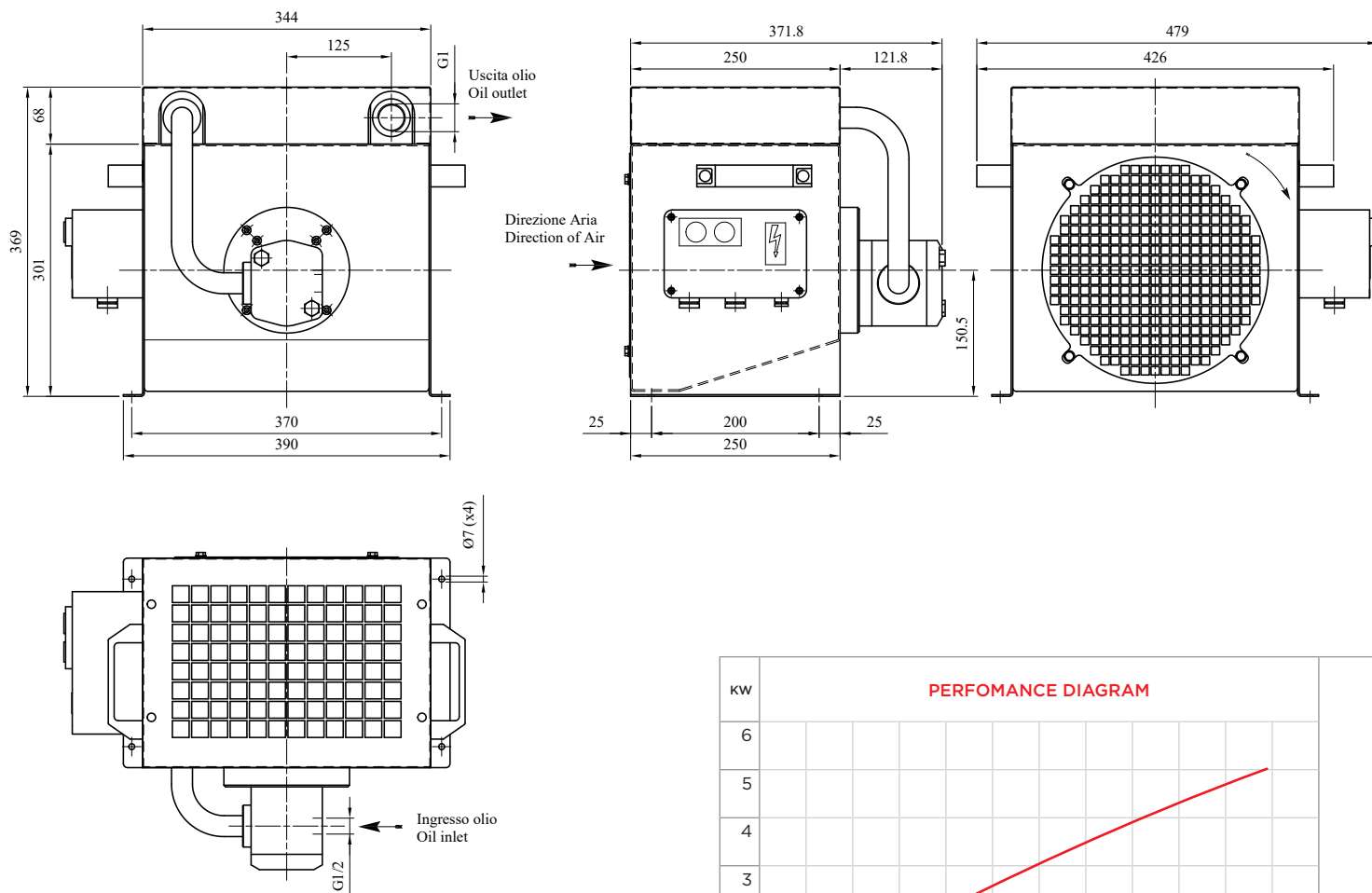

OIL FLOW	VOLTAGE		HZ	POWER	CURRENT	ELECTRICO PROTECTION	AIR FLOW	NOISE LEVEL	WEIGHT
l/min	Δ	Y		W	A	IP	m³/h	dB(A)	kg
13	230	400	50	550	2,95/1,70	55	850	68	18
15	265	460	60	640	2,95/1,70	55	1.000	68	18

PURCHASE CODES

RAS 1000 without thermo-switch	3RRAS1000
RAS 1000 with thermo-switch	3RRAS1000T

SPARE PARTS

Electronic thermo-switch	1TRM RAS
2m thermo-switch probe	1SND RAS
4m thermo-switch probe	1SND ROC4M
Oil filter	1FTR MPS50
Electric junction box	1CSSDSAR336
Cooling element	1ROO3378
Cooling element protection grill	3TLPRAS1000.1
Housing	3TLRAS1000.1
Fan	1GRAS1000
Fan grill	3RTRAS1000.1
Pump	1PORAS3000
Electric motor	1MRAS3000

RAS 3000

SELF CONTAINED COOLING UNIT
UNITÀ DI RAFFREDDAMENTO A CORRENTE ALTERNATA SERIE RAS



- Dimensions and technical characteristics are not binding

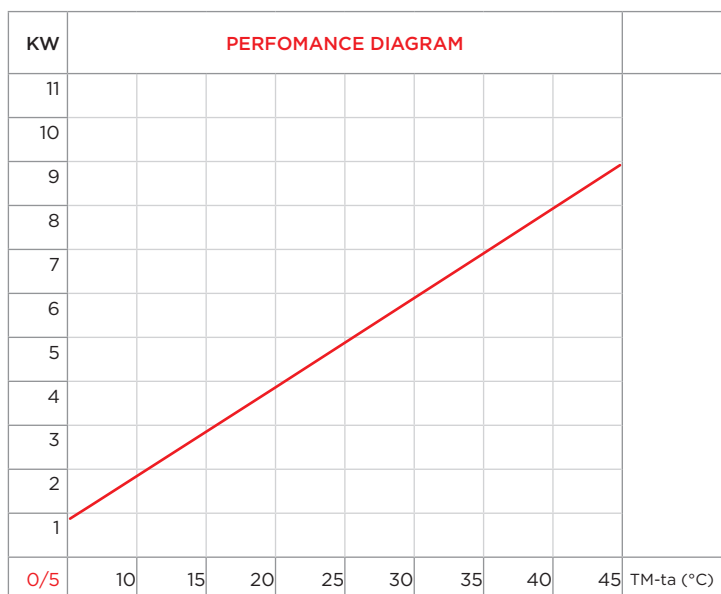
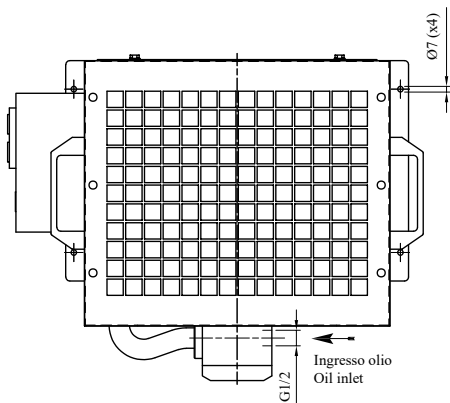
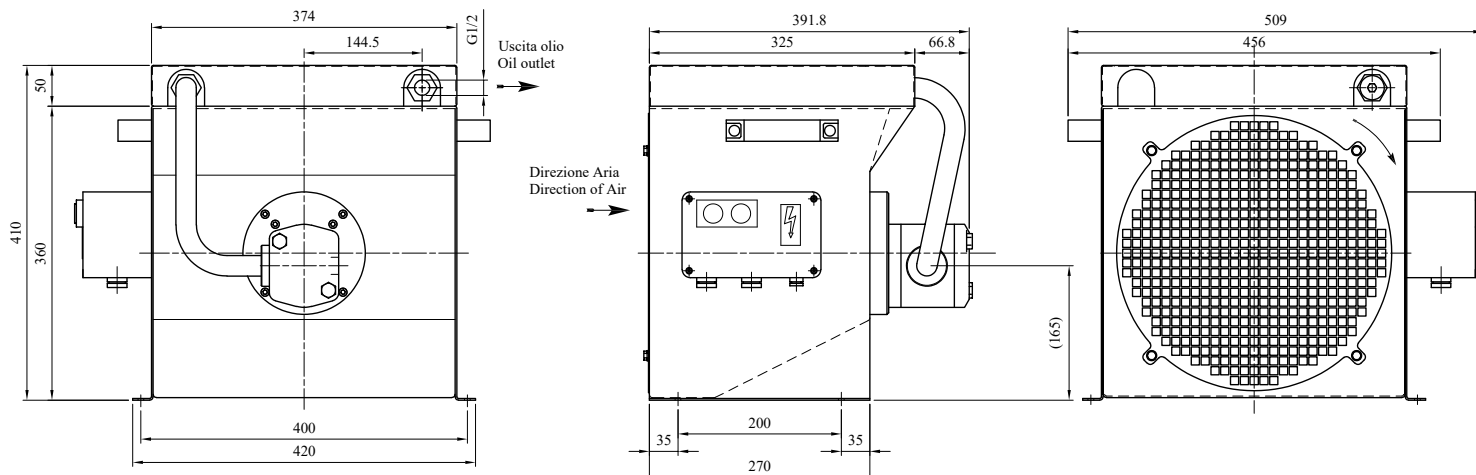

OIL FLOW	VOLTAGE		HZ	POWER	CURRENT	ELECTRICO PROTECTION	AIR FLOW	NOISE LEVEL	WEIGHT
l/min	Δ	Y		W	A	IP	m³/h	dB(A)	kg
13	230	400	50	550	2,95/1,70	55	850	68	24
15	265	460	60	640	2,95/1,70	55	1.000	68	24

PURCHASE CODES

RAS 3000 without thermo-switch	3RRAS3000
RAS 3000 with thermo-switch	3RRAS3000T

SPARE PARTS

Electronic thermo-switch	1TRM RAS
	1SND RAS
	1SND ROC4M
Oil filter	1FTR MPS50
Electric junction box	1CSSDSAR336
Cooling element	1RONO1
Cooling element protection grill	3TLPRAS3000.1
Housing	3TLRAS3000.1
Fan	1GRAS3000
Fan grill	3RTRAS3000.1
Pump	1PORAS3000
Electric motor	1MRAS3000

RAS 5000

SELF CONTAINED COOLING UNIT
UNITÀ DI RAFFREDDAMENTO A CORRENTE ALTERNATA SERIE RAS



- Dimensions and technical characteristics are not binding

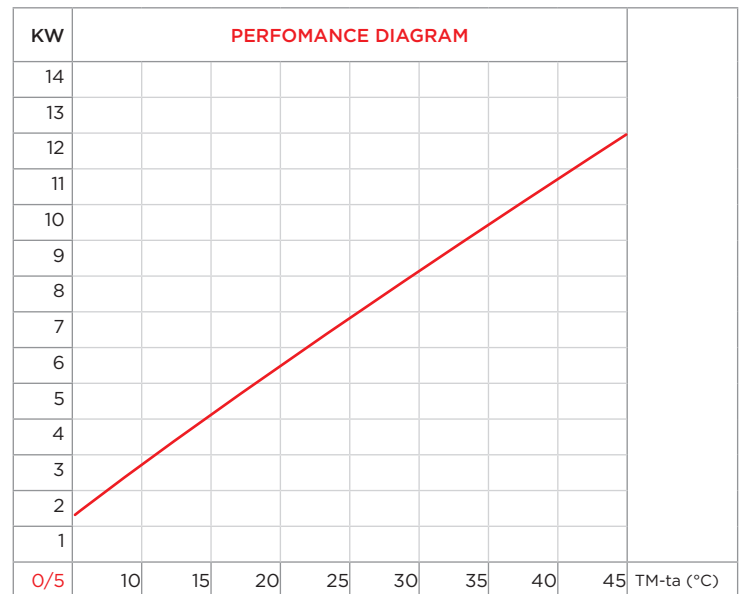
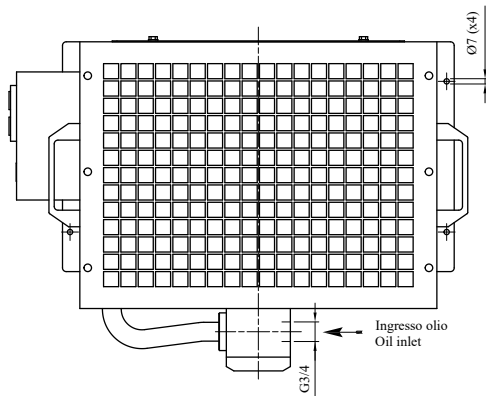
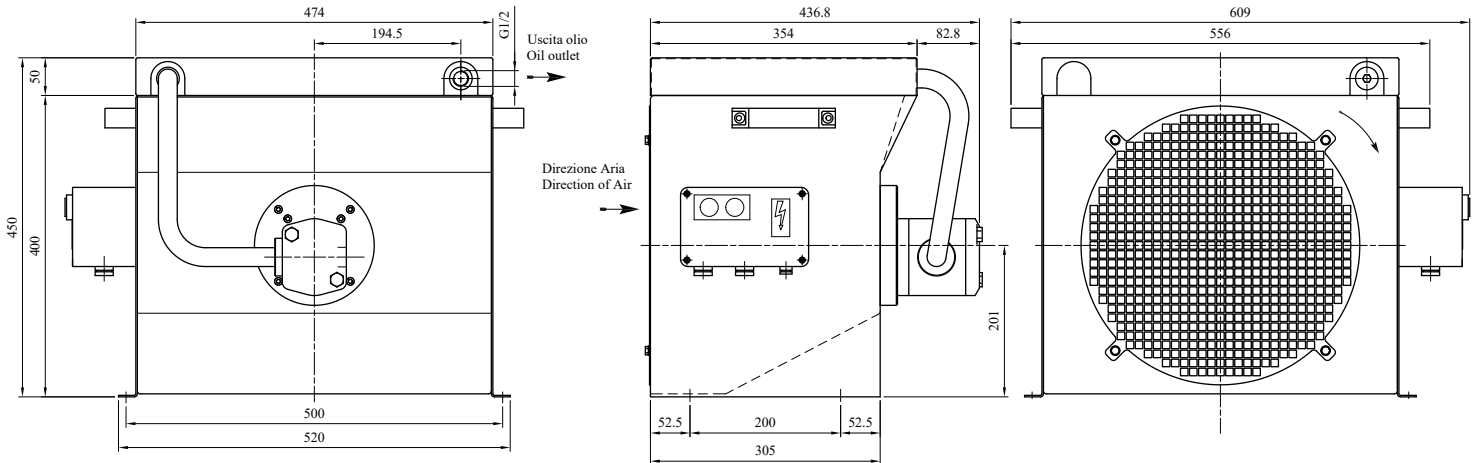

OIL FLOW	VOLTAGE		HZ	POWER	CURRENT	ELECTRICO PROTECTION	AIR FLOW	NOISE LEVEL	WEIGHT
l/min	Δ	Y		W	A	IP	m³/h	dB(A)	kg
22	230	400	50	750	3,6-2,1	55	1.500	70	36
26	265	460	60	870	3,6-2,1	55	1.800	70	36

PURCHASE CODES

RAS 5000 without thermo-switch	3RRAS5000
RAS 5000 with thermo-switch	3RRAS5000T

SPARE PARTS

Electronic thermo-switch	1TRM RAS
	1SND RAS
	1SND ROC4M
Oil filter	1FTR MPS50
Electric junction box	1CSSDSAR336
Cooling element	1RONO3
Cooling element protection grill	3TLPRAS5000.1
Housing	3TLRAS5000.1
Fan	1GRAS5000
Fan grill	3RTRAS5000.1
Pump	1PORAS5000
Electric motor	1MRAS5000

RAS 7000

SELF CONTAINED COOLING UNIT
UNITÀ DI RAFFREDDAMENTO A CORRENTE ALTERNATA SERIE RAS



- Dimensions and technical characteristics are not binding

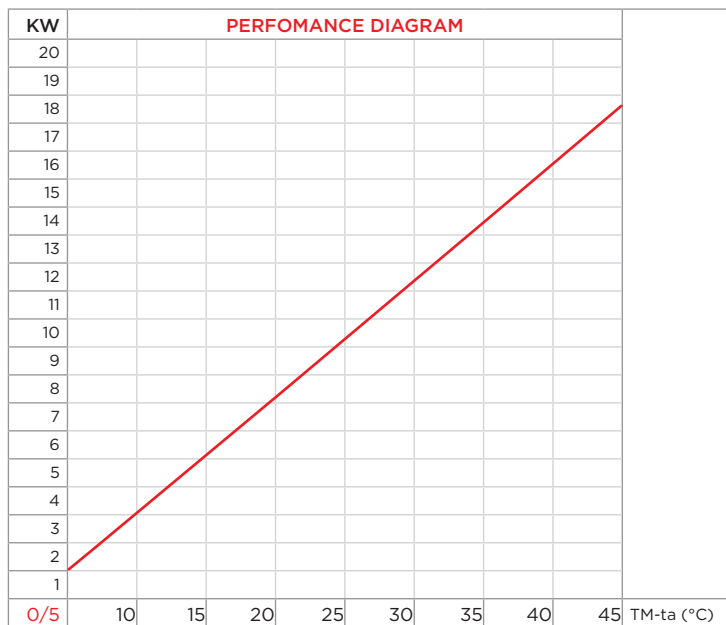
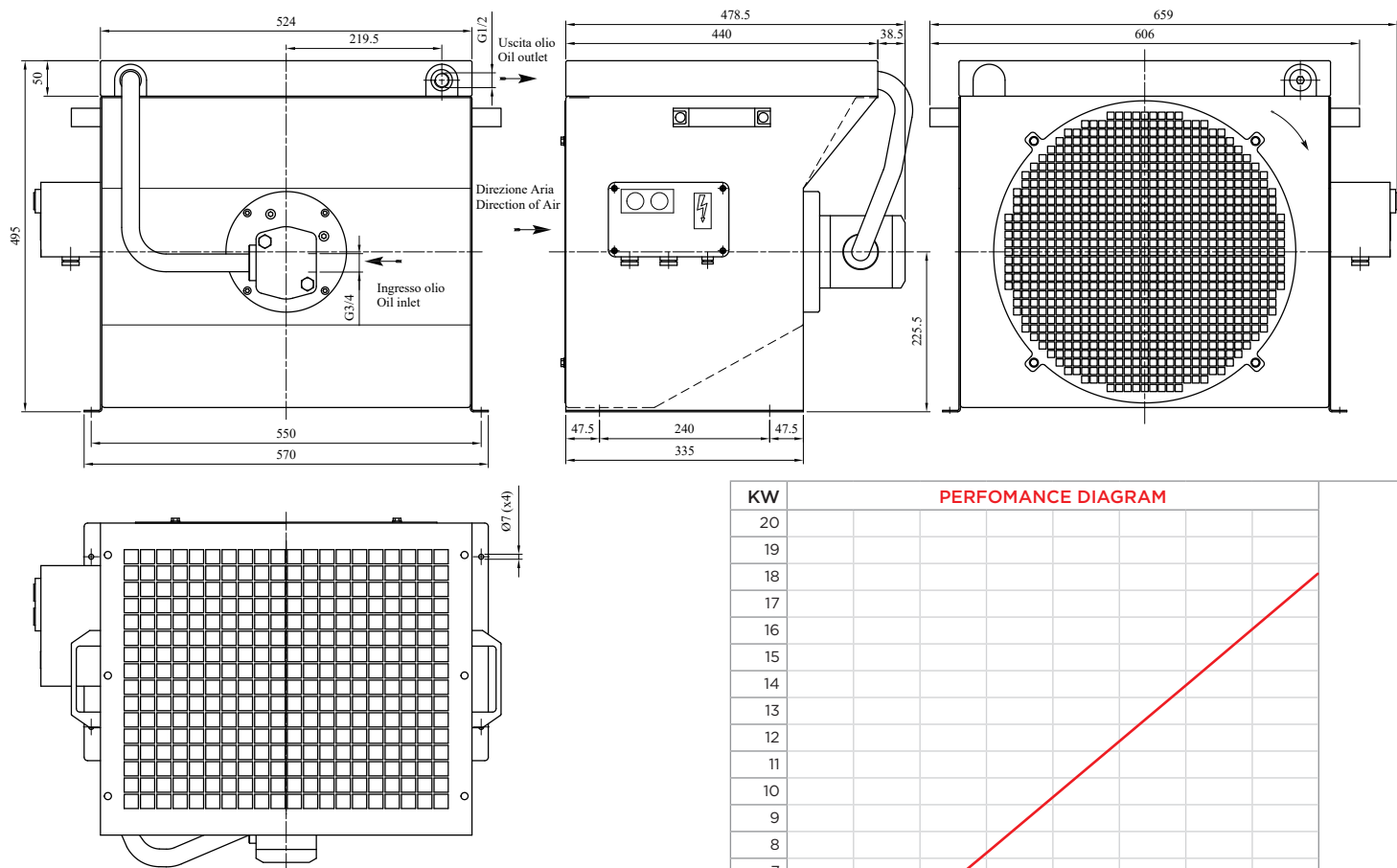

OIL FLOW	VOLTAGE		HZ	POWER	CURRENT	ELECTRICO PROTECTION	AIR FLOW	NOISE LEVEL	WEIGHT
l/min	Δ	Y		W	A	IP	m³/h	dB(A)	kg
34	230	400	50	1100	4,3/2,5	55	2.000	75	58
41	254	440	60	1100	4,0/2,3	55	2.400	75	58

SPARE PARTS

Electronic thermo-switch	1TRM RAS
	1SND RAS
	1SND ROC4M
Oil filter	1FTR MPS50
Electric junction box	1CSSDSAR336
Cooling element	1RONO4
Cooling element protection grill	3TLPRAS7000.1
Housing	3TLRAS7000.1
Fan	1GRAS7000
Fan grill	3RTRAS7000.1
Pump	1PORAS7000
Electric motor	1MRAS7000

PURCHASE CODES

RAS 3000 without thermo-switch	3RRAS7000
RAS 3000 with thermo-switch	3RRAS7000T

ASSEMBLING AND MAINTENANCE INSTRUCTIONS OF THE SELF CONTAINED COOLING UNITS

Assembling

The exchanger must be assembled so that the airflow is not obstructed both in the inlet and in the outlet of the cooling element. To obtain a better efficiency it is important to avoid any recycling of warm air between inlet and aspiration.

It is important to have enough air-recycle into the area where the unit is installed, in order to avoid that the air itself became warm, compromising this way the functioning of the exchanger.

The air flow have to be guided to avoid bothering the operator.

The self-contained cooling unit has to be connected with flexible tubes to the tank to cool. It is indispensable that the suction tube has the same or a bigger diameter that the one of the fitting existing on the unit. Otherwise, it is possible to encounter cavitation phenomena that could cause high noise or could break the pump.

For the same reason, the suction tube do not have to offer extreme pressure losses and it is better to avoid winding way, diameter reductions, etc.

Avoid outlet obstructions of the pump to avoid, consequently, putting the cooling element, that has a max. working pressure of 2 bar, under high pressures.

If the unit has to be placed higher that the oil level, using a self-priming gear pump, allows positioning the unit to a max. height of 2 meters between the pump and the oil level, on exceeding heights the pump could cavitate.

Operating

As first check that the tension correspond to the one on the heat exchanger plate. Before operating, it is necessary to check that the pump motors and the fan rotate to the direction shown by the arrow. The tension allows the functioning of the pump only, while the fan is controlled through a thermo switch that sets it on when the oil temperature exceed the one selected by the operator.

If there is a need of a continuous working of the fan, turn the thermo switch knob on the minimum value.

MAINTENANCE

Oil side cleaning

For this kind of cleaning, the unit must be disassembled from the machine so that the cooling element from the exchanger.

In order to remove the dirt, let a detergent circulate from 10 to 30 minutes, then proceed removing the detergent with compressed air. During the circulation of the detergent pay attention that its pressure does not exceed the maximum allowed pressure of the exchanger.

Air side cleaning

It can be carried with compressed air or water. The direction of the stream must be parallel to the fins to avoid damaging them. It could be more efficient to use a detergent.

If the dirt consists of oil or grease, it is possible to use a stream of steam or hot water, paying attention always to the stream direction. During the cleaning the electric motor has to be adequately protected.

ISTRUZIONI DI MONTAGGIO, MESSA IN MARCIA E MANUTENZIONI GRUPPI AUTONOMI DI RAFFREDDAMENTO

Montaggio

Il gruppo deve essere installato in modo che l'aria non sia ostacolata nel suo fluire sia in aspirazione che in uscita dal pacco radiante.

E' indispensabile che nel locale in cui funziona esista un ricambio d'aria sufficiente in modo che l'aria stessa non venga riscaldata pregiudicando la resa termica dello scambiatore.

Si deve inoltre fare in modo che il flusso d'aria non vada ad infastidire l'operatore.

I Gruppi Autonomi devono essere collegati con tubi flessibili al serbatoio che devono raffreddare.

E' indispensabile che il tubo di aspirazione sia di diametro uguale o superiore al diametro del raccordo esistente sul gruppo; in caso contrario si potrebbero verificare fenomeni di cavitazione che causerebbero rumorosità elevata e possibile rottura della pompa.

Per lo stesso motivo il tubo di aspirazione non deve offrire eccessive perdite di carico e si devono pertanto evitare percorsi tortuosi, riduzione di diametri, ecc..

Si devono anche evitare ostruzioni in mandata per non mettere in pressione il pacco radiante, la cui massima pressione di funzionamento è di 2 bar.

Nel caso si debba posizionare il Gruppo più in alto del livello dell'olio, l'impiego di una pompa a ingranaggi autoadescente consente di posizionarlo ad un'altezza massima di 2 metri tra la pompa e il livello dell'olio; ad altezze superiori la pompa potrebbe cavitare.

Funzionamento

Si deve innanzitutto verificare che la tensione e la frequenza di alimentazione corrisponda a quella indicata sulla targhetta.

All'atto della messa in marcia è indispensabile controllare che i motori elettrici della pompa e della ventola ruotino nel senso indicato dalle frecce.

Dando tensione, entra in funzione la sola pompa, mentre la ventola è comandata da un termostato che la fa intervenire quando la temperatura dell'olio supera quella selezionata dall'operatore.

Nel caso si desiderasse un funzionamento continuo della ventola, è sufficiente ruotare la manopola del termostato sul valore minimo.

MANUTENZIONE

Pulizia lato olio

Per tale tipo di pulizia il gruppo deve essere smontato dalla macchina, così come il pacco radiante dal gruppo. Lo sporco potrà essere eliminato con circolazione di prodotto detergente.

La durata di questa operazione dipende naturalmente dal grado di sporco: può variare dai 10 ai 30 minuti. Dopo questa operazione il prodotto resta all'interno e bisognerà quindi procedere alla sua espulsione tramite aria compressa.

Nel corso della circolazione del prodotto di pulizia bisogna fare attenzione che la sua pressione non superi quella massima ammessa dallo scambiatore.

Pulizia lato aria

Essa potrà essere effettuata mediante aria compressa o acqua. La direzione del getto dovrà essere parallela alle alette per non danneggiarle.

Il risultato può essere migliore con l'aggiunta di un prodotto detergente.

Se l'accumulo di sporco è causato da olio o da grasso, la pulizia potrà essere effettuata con un getto di vapore o di acqua calda, facendo sempre attenzione alla direzione del getto.

Durante le operazioni di pulizia, i motori elettrici dovranno essere convenientemente protetti.

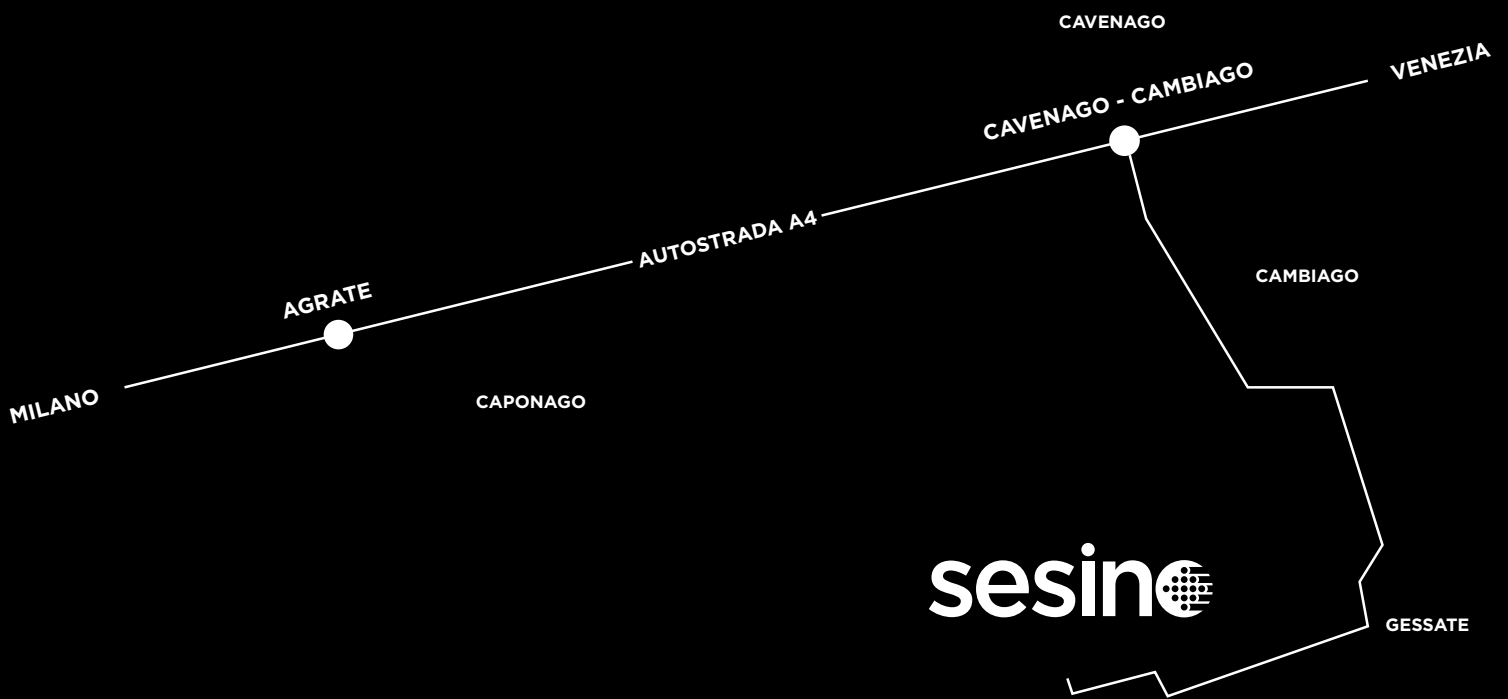

Scan the following
QR Code to reach us:





sesino

COSTANTE SESINO SPA:

via Monza, 150 A/B 20060 GESSATE (MI)

info@sesino.com - www.sesino.com

tel. +39 02.95.38.03.34