

sesino

HEAT EXCHANGING EXCELLENCE SINCE 1919



**AIR OIL HEAT EXCHANGERS BC
WITH INTEGRATED BY-PASS VALVE
SCAMBIATORI ARIA/OLIO SERIE BC
CON VALVOLA DI BY-PASS INTEGRATA**

BY-PASS VALVE OPERATING PRINCIPALE

The new BC line can be equipped with an integrated by-pass valve.

It is available on the following types: BC 250, BC 250/2, BC 390, BC 390/2 e BC 390/3

The operating principle of the by-pass valve is the following: the valve is inside the lower tank, front of the oil-inlet connection; when the pressure inside the tank exceed the load spring pressure, the valve opens allowing the oil to circulate into a duct obtained inside the cooling element side instead of inside the cooling element itself.

The use of the by-pass valve is useful most of all during the cold start in winter season and, when the oil flows inside the exchanger are variable.

The standard load pressure is 4 bar, but different loads are available upon request.

FUNZIONAMENTO VALVOLA BY-PASS INTEGRATA

La nuova serie BC può essere fornita anche con valvola di by-pass integrata.

La valvola di by-pass può essere applicata sui seguenti modelli: BC 250, BC 250/2, BC 390, BC 390/2 e BC 390/3

Il principio di funzionamento è il seguente: La valvola è inserita nella vasca inferiore, di fronte al raccordo di entrata olio; quando la pressione all'interno della vasca supera la pressione di taratura della molla, la valvola si apre facendo circolare l'olio in un condotto ricavato su un fianco del radiatore invece che all'interno del radiatore stesso.

L'utilizzo della valvola di by-pass è utile soprattutto negli avviamenti a freddo durante la stagione invernale e quando le portate olio circolanti nello scambiatore sono molto variabili.

La pressione di taratura standard è di 4 bar; tarature diverse possono essere fornite su richiesta.

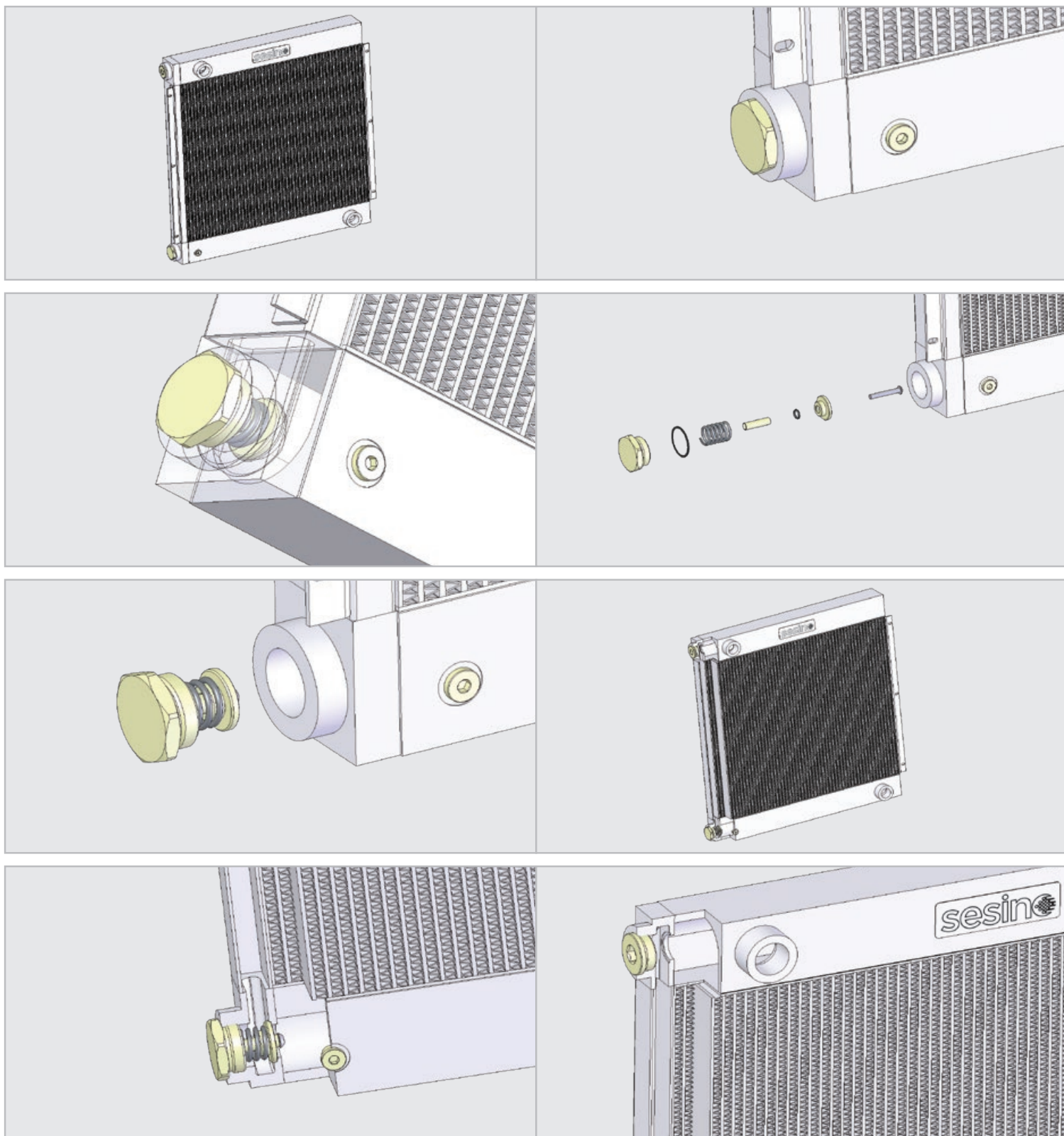

OUR PHILOSOPHY

FILOSOFIA AZIENDALE

SESINO philosophy has its grounding on the following principles.

- 1. Full quality**, meant to be product's quality, assistance and organization quality, quality of our raw materials and our measuring and checking instruments, everything according to ISO 9001:2008 Regulation.
- 2. Occupational safety**, a commitment to our staff, in order to grant them no risks while working. A policy for which we obtained BS OHSAS 18001:2007 Certification.
- 3. Proactive Skills**, Sesino aptitude to support and cooperate with customers in order to optimize the development of their projects. SESINO can offer custom-made products, produced according to our client's needs, using our experience, knowledge, human resources and technology.
- 4. Competitiveness**, which means to be able to face our competitors and believe that we can succeed. This feature is the result of corporate growth, increase in the sales volume, expense reduction and the possibility to invest in technology and marketing research.

La filosofia aziendale della SESINO pone le sue basi sui seguenti fondamenti.

- 1. Qualità totale**, intesa come qualità del prodotto, qualità del servizio, qualità dell'organizzazione, qualità degli strumenti di controllo, qualità delle materie prime, ma non solo a parole, bensì certificata secondo le norme ISO 9001:2008.
- 2. Sicurezza sul lavoro**, un impegno che ci siamo assunti nei confronti di tutti i nostri collaboratori perché possano lavorare senza rischi di incidenti, anche qui, non solo a parole, bensì certificata secondo la Norma BS OHSAS 18001:2007
- 3. Capacità propositiva**, intesa come un preciso impegno della SESINO a essere vicina in modo particolare ai costruttori allo scopo di collaborare con gli stessi per l'ottimizzazione e lo sviluppo dei loro progetti. È inoltre una caratteristica produttiva della SESINO quella di poter offrire prodotti fuori standard, costruiti in funzione delle specifiche esigenze della clientela; questo naturalmente presuppone conoscenza, esperienza, risorse umane e tecnologiche per affrontare e risolvere i problemi.
- 4. Competitività**, che significa doversi e potersi misurare con tutti gli antagonisti, con la consapevolezza di poter anche essere vincenti. La competitività è senza dubbio il risultato di diversi componenti quali la crescita aziendale, l'incremento del fatturato, il contenimento delle spese, la possibilità di finanziare investimenti tecnologici per la ricerca, per il marketing e così via.



HISTORY STORIA

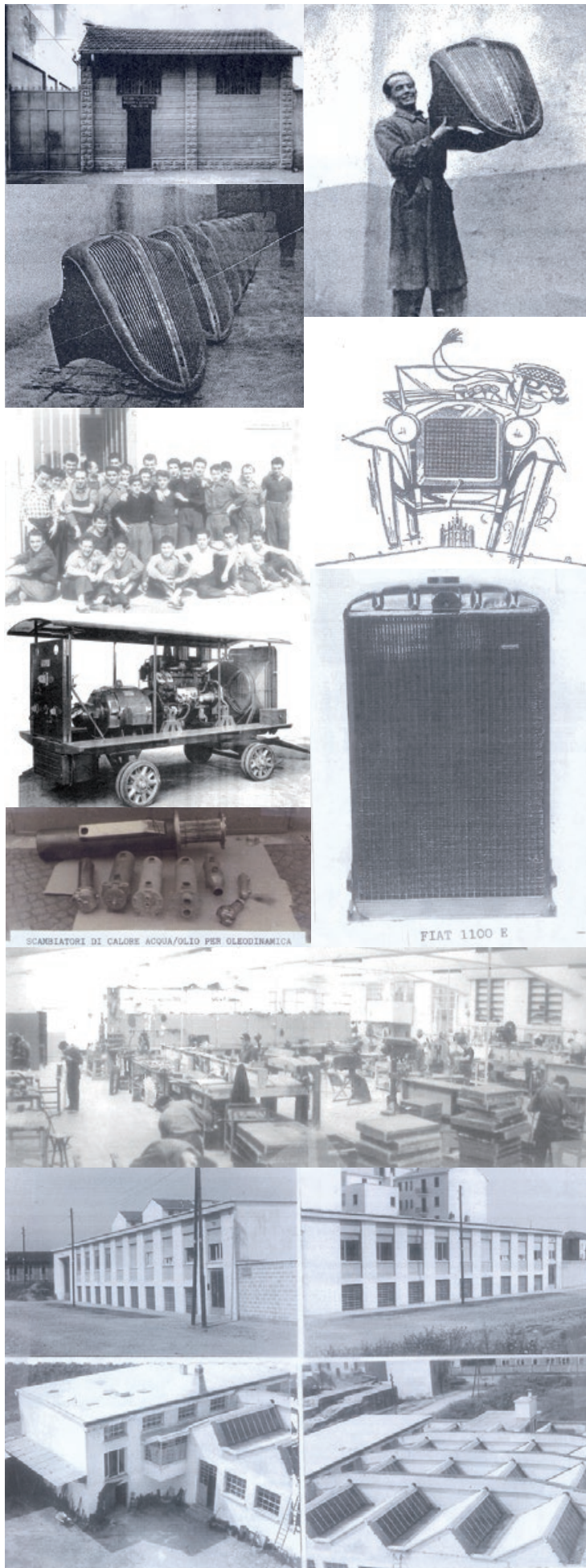

1919

The Sesino brothers founded the company Flli Sesino & C., having as its main activity the production and maintenance of grills and radiators for vehicles. *I fratelli Sesino costituiscono la Flli Sesino & C., avente come attività la costruzione e riparazione di mascherine e radiatori per automobili.*

1920

Flli Sesino & C. took part into the first Exhibition in Milan and got several statements and rewards for its activity. *La Flli Sesino & C. partecipa alla prima FIERA DI MILANO e ottiene attestazioni e riconoscimenti per l'attività svolta.*

1922

Flli Sesino & C., after having received a big order for the production of car radiators from company Edoardo Bianchi, moved from the old workshop to the new place in Via Noè, Milan. Until the II World War, the company got several orders for grills and radiators from Bianchi and FIAT. Then, in the new site began the production of gas and electric unit heaters, condensers and evaporators for the first refrigerating systems. *La Flli Sesino & C., acquisita una fornitura di radiatori per la casa automobilistica EDOARDO BIANCHI, si trasferisce dalla bottega artigiana degli esordi in una nuova sede in Via Noè a Milano. Fino allo scoppio della seconda guerra mondiale, vengono acquisiti ordini per forniture di mascherine e radiatori, oltre che dalla EDOARDO BIANCHI, dalla FIAT. In questa nuova sede inizia la produzione di aerotermi a gas ed elettrici, condensatori ed evaporatori per i primi impianti frigoriferi.*

1934

With the resignation of brother Alfredo the company became Costante Sesino & C. *Con le dimissioni del fratello Alfredo, la Società si trasforma in Costante Sesino & C.*

1945

Finished the II World War, among the several difficulties, Costante Sesino & C. restarted the production of radiators, evaporators and condensers. *Terminata la seconda guerra mondiale, tra le mille difficoltà dei tempi, la Costante Sesino & C. ricomincia a produrre radiatori, evaporatori e condensatori.*

1948

Began the production of radiators for cars, trucks and tractors for the spare parts market. This activity absorbed entirely Costante Sesino production for more than a decade. *Inizia la produzione di radiatori per auto, autocarri e trattori destinata al mercato del ricambio, che occupa la Costante Sesino & C. in maniera esclusiva per oltre un decennio.*

1954

Construction of the new company headquarter in Via Doberdò, Milan, which after further enlargements reached a covered area of 2500 m². *Costruzione della nuova sede di Via Doberdò, sempre a Milano che, con vari successivi ampliamenti, raggiunge una superficie coperta di oltre 2500 m².*

1955

Against request of a producer of injection presses for plastic material, who was forced to supply in the USA, Costante Sesino & C. started the production of tube-bundle heat exchangers for oil cooling in oleo hydraulic systems. *Su sollecitazione di un costruttore di presse a iniezione per materie plastiche, costretto ad approvvigionarsi degli scambiatori di calore a fascio tubiero negli Stati Uniti, la Costante Sesino & C. inizia la produzione di scambiatori di calore a fascio tubiero per il raffreddamento dell'olio di impianti oleoidraulici.*

1960

Using the experience in the construction of radiators, Costante Sesino & C. began producing air-oil heat exchangers intended to cool mobile and industrial machine's systems, combined radiators for the cooling of water and oil, exchanger for compressors and radiators for power units. *Sfruttando l'esperienza precedente nella costruzione di radiatori, la Costante Sesino & C. inizia la produzione di scambiatori di calore aria-olio destinati al raffreddamento di macchine mobili e industriali,*

alla costruzione di radiatori combinati per raffreddamento acqua e olio, al raffreddamento di compressori, alla costruzione di radiatori per gruppi elettrogeni.

1970

The production of radiators for the spare parts market was definitely abandoned in order to concentrate exclusively on the oleo hydraulic market. *Viene deciso di abbandonare la produzione di radiatori per il mercato del ricambio per dedicarsi esclusivamente al mercato oleoidraulico.*

1988

Began the production of aluminum air-oil heat exchangers, which will onwards substitute the brass/copper production. *Inizia la produzione di scambiatori aria-olio in alluminio che andrà progressivamente a sostituire negli anni successivi quella in ottone/frame.*

1999

The company Costante Sesino becomes part of the Tognella Group. *La società Costante Sesino entra a far parte del gruppo Tognella.*

2003

Costante Sesino S.p.A. moved to the current seat in Gessate (Milan): a modern place with a 4000 m² producing area and 400 m² offices. *Trasferimento della Costante Sesino S.p.A. nell'attuale sede di Gessate in provincia di Milano: si tratta di una moderna sede industriale di oltre 4000 m² di superficie produttiva, oltre a 400 m² di uffici.*

2009

Introduction of custom-made heat exchangers with different materials and size, addressed mainly to the energy market. *Introduzione di una produzione di scambiatori speciali, destinati al mercato energetico, costruiti con materiali diversi dallo standard, e fornibili con specifiche certificazioni richieste dai clienti.*

2011

Costante Sesino obtained the Certification EN ISO 9001/2008. *Raggiungimento della certificazione di qualità ISO 9001/2008.*

2012

Costante Sesino obtained the OHSAS 18001/2007 Certification for occupational health and safety management system. *Raggiungimento della certificazione OHSAS 18001/2007 per la salute e la sicurezza sul lavoro.*

2017

The company returns entirely to the ownership of the Sesino family. *La società ripassa definitivamente al 100% nella mani della famiglia Sesino.*

2019

Costante Sesino proudly celebrates the company's centenary. *Costante Sesino festeggia con grande orgoglio il centenario della società.*

2020

Significant investments in automation and production management. *Ingenti investimenti per l'automazione e gestione della produzione.*

2021

Introduction of the new MSG shell and tube heat exchanger line, eliminating welding entirely. *Inserimento della nuova linea di scambiatori fascio tubiero MSG con eliminazione definitiva di saldature.*

2022

Definitive establishment in the compressor market with high-pressure shell and tube heat exchangers for hydrogen and other gases. *Affermazione definitiva nel settore compressori con gli scambiatori fascio tubiero alta pressione per idrogeno e altri gas.*

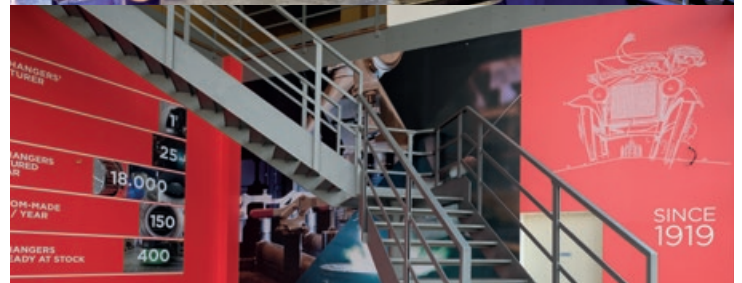
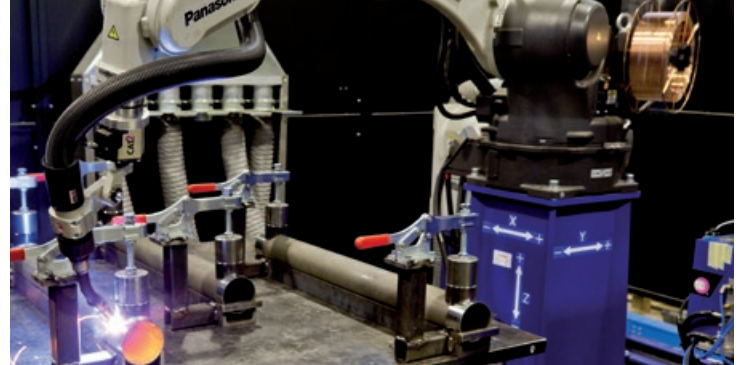

HEAT EXCHANGING: GENERAL INFORMATION

GENERALITÀ SULLA TRASMISSIONE DEL CALORE

How heat is transferred

The term heat transmission means the processes through which heat is transferred from one body to another or from different points of the same body, because of the presence of temperature differences. The transmission way changes according to the nature of the body. In a solid body, heat is transferred by conduction, in a liquid by convection, while the third method, radiation, depends on the electromagnetic properties of the bodies involved. This last case is not particularly relevant in the heat exchangers field and thus, only the first two phenomena will be briefly described.

Conduction

Let us suppose to have a flat plate and that the two faces of the plate are in some way kept at two different temperatures: T1 and T2. There will be a flow of heat from the face with an higher temperature T1 to the one with a lower temperature T2, without any movement of matter. We say that heat is transmitted from one point to another by conduction.

Convection

Now let us consider the case of a body immersed in a fluid. If the temperature of the body is higher than that of the fluid, heat will flow from the former to the latter. Since the temperature of the fluid in contact with the wall is higher than the one of the fluid distant from the wall, a movement is established because of the different densities at the two points. The phenomenon of heat transmission related to this state of motion is called convection.

While conductivity depends exclusively on the material, heat exchange by convection depends on the type of fluid, its condition of motion and the shape of the surface.

General information on heat exchangers and their sizing

Heat exchangers are devices, which allow the exchange of heat between two moving fluids at different temperatures. The two fluids are generally separated by a solid surface, which is usually metal. Heat exchangers can be divided into three groups according to the motion of the two fluids inside.

- parallel current heat exchanger, when the two fluids move in parallel and in the same direction at all points of the exchanger;
- counter current heat exchangers, where the two fluids move in parallel but in opposite directions;
- crosscurrent heat exchangers, where the two fluids move at right-angles to each other.

Sizing a heat exchanger means to calculate the needed exchange surface which is a function of the quantity of heat to dissipate, of the temperatures and the oil flow rates of the two fluids.

Problems regarding oil cooling

The viscosity of oil increases as its temperature decreases. When oil encounters a cold surface in a heat exchanger, it forms an isolating stratum. The thickness of this stratum is inversely proportional to the possibility of heat exchange.

To obtain optimal thermal efficiency, the flow rate of the oil over the exchange surface must be such as to ensure that the thickness of this stratum is as low as possible. In practice, this means that it is essential to ensure that the flow rate of the oil inside the heat exchanger is higher than the minimum indicated on the catalogues.

Sizing of air-oil heat exchangers to be installed on hydraulic system

The technical data required are the same of water-oil heat exchangers, as well as the ambient temperature at which the heat exchanger has to work.

Sizing an air-oil heat exchanger consists, practically, in calculating the needed specific performance, called Kr, and choosing the heat exchanger having the higher specific performance.

$Kr = Q/\Delta T$ where ΔT is the difference between oil inlet temperature and maximum summer ambient temperature, while Q is the quantity of heat to be dissipated which can be easily calculated considering 20-30% of installed power.

To choose the right cooler you must check the diagrams into the technical catalogue.

Example

N = 20 kW
q = 80 lpm
To = 50°C
Tamb = 30°C

Q = 30% 20 = 6 kW = 5.160 kcal/h

$\Delta T = 50 - 30 = 20^\circ C$

Kr = 5.160/20 = 258 kcal/h°C

Drawing a vertical line on the diagram in correspondence with the flow rate 80 l/min, the intersection of this line with the curves gives on ordinates the Kr that each heat exchanger is able to grant in that condition

Le vie del calore

Tutti sanno che per "trasmissione del calore" si intendono i processi attraverso cui, a causa di differenze termiche esistenti, il calore si trasferisce da un corpo ad un altro o a punti diversi dello stesso corpo.

Queste modalità, ovviamente, cambiano a seconda che si verifichino in un solido (conduzione), in un liquido (convezione) o per le proprietà elettromagnetiche dei corpi (irraggiamento).

Quest'ultimo caso non riveste particolare rilevanza nel campo degli scambiatori di calore e perciò riteniamo utile accennare solo ai primi due fenomeni.

La conduzione

Supponiamo di avere una lastra piana e di mantenere con qualsiasi artificio le due facce a due temperature diverse: T1>T2. Vi sarà un flusso di calore dalla faccia a temperatura superiore a quella a temperatura inferiore senza movimento di materia; diremo che il calore si trasmette da un punto ad un altro per conduzione.

La convezione

Consideriamo di avere un corpo immerso in un fluido; se la temperatura del corpo è superiore a quella del fluido, vi sarà un flusso di calore dal primo al secondo.

Poiché la temperatura del fluido a contatto con la parete è più alta di quella di un punto lontano dalla parete, si stabilisce un movimento causato dalle diverse densità nei due punti: il fenomeno di trasmissione del calore che è legato a questo stato di moto si chiama convezione.

A differenza della conducibilità che dipende esclusivamente dal materiale, il calore scambiato per convezione trova le sue ragioni, oltre che nel tipo di fluido, nelle condizioni di moto di questo e nella forma della superficie.



Generalità sugli scambiatori di calore e loro dimensionamento

Gli scambiatori di calore sono apparecchi che consentono lo scambio del calore tra due fluidi in movimento a diverse temperature. I due fluidi sono generalmente separati tra loro da una superficie solida, quasi sempre metallica.

Gli scambiatori di calore, in relazione al moto dei due fluidi all'interno dell'apparecchio, si possono dividere in tre gruppi:

- a) scambiatori in equicorrente, se i due fluidi si muovono in ogni punto dell'apparecchio parallelamente e nella stessa direzione;
- b) scambiatori in controcorrente, se i due fluidi si muovono parallelamente, ma in direzioni opposte;
- c) scambiatori a correnti incrociate, se il flusso dei fluidi è ortogonale.

Dimensionare uno scambiatore significa calcolare la superficie di scambio necessaria, che è funzione della quantità di calore da disperdere, delle temperature e delle portate dei due fluidi.

Problemi inerenti al raffreddamento dell'olio

L'olio è un fluido che, con il diminuire della temperatura, aumenta la sua viscosità. Quando in uno scambiatore di calore esso viene a contatto con una superficie fredda, esso forma uno strato isolante il cui spessore è inversamente proporzionale alla possibilità di scambiare calore.

Per ottenere una resa termica ottimale bisogna fare in modo che la velocità di scorrimento dell'olio sulla superficie di scambio sia tale da rendere il più basso possibile lo spessore di tale strato; ciò in pratica si traduce nella assoluta esigenza che negli scambiatori circoli una portata d'olio superiore alla minima indicata sui cataloghi.

Dimensionamento degli scambiatori di calore aria-olio da installare su impianti oleoidraulici

I dati da richiedere sono gli stessi dello scambiatore acqua-olio, oltre, naturalmente, alla temperatura dell'aria ambiente a cui deve funzionare lo scambiatore.

Il dimensionamento dello scambiatore consiste essenzialmente nel calcolo della potenzialità specifica necessaria, chiamata Kr , e scegliere lo scambiatore avente potenzialità specifica immediatamente superiore.

$Kr = Q/\Delta T$, dove ΔT è la differenza tra la temperatura entrata olio e la temperatura ambiente massima estiva e Q è la quantità di calore da disperdere che si calcola considerando il 20-30% della potenza installata.

Per scegliere lo scambiatore idoneo bisogna consultare i diagrammi del catalogo tecnico. Tracciando sui diagrammi una retta verticale in corrispondenza della portata 80 l/min, l'intersezione di tale retta con le curve fornisce in ordinate il Kr che ogni scambiatore è in grado di garantire in quella condizione.

Esempio: $N = 20 \text{ kW}$; $q = 80 \text{ lpm}$; $T_o = 50^\circ\text{C}$; $T_{amb} = 30^\circ\text{C}$

$$Q = 30\% 20 = 6 \text{ kW} = 5.160 \text{ kcal/h}$$

$$\Delta T = 50 - 30 = 20^\circ\text{C}$$

$$Kr = 5.160/20 = 258 \text{ kcal/h}^\circ\text{C}$$

La scelta dello scambiatore si esegue utilizzando le curve presenti sul catalogo tecnico. Tracciando una retta verticale in corrispondenza della portata di 80 lpm, l'intersezione con le varie curve di resa fornisce in ordinate il Kr dei diversi scambiatori.

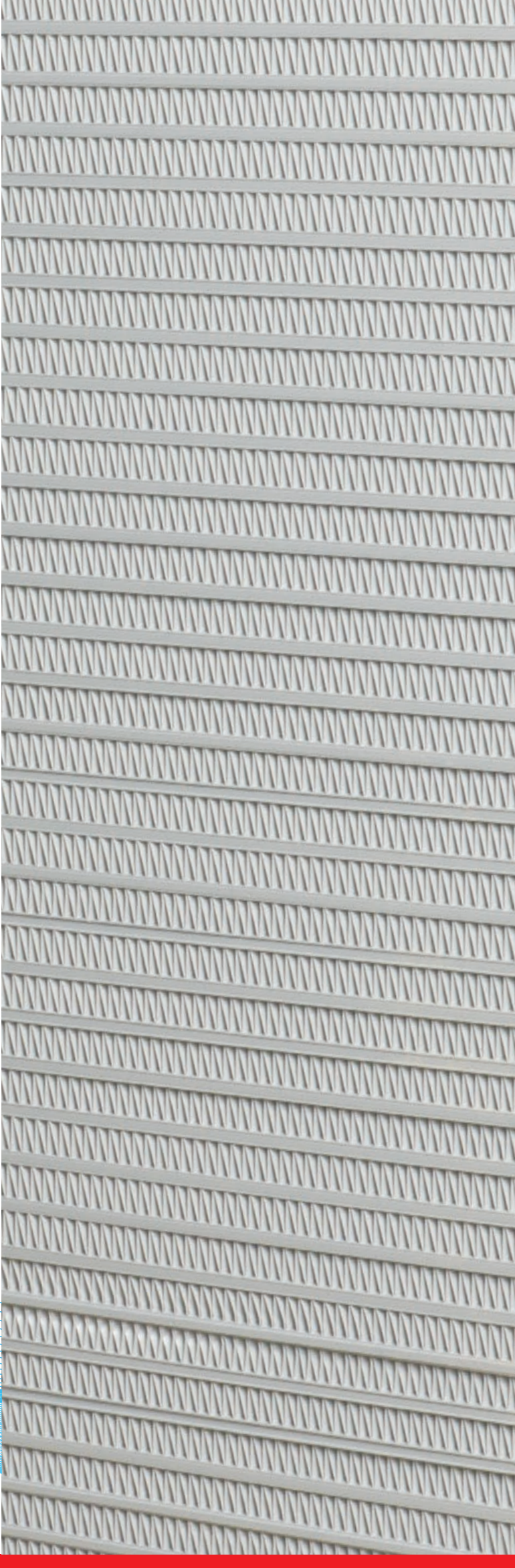
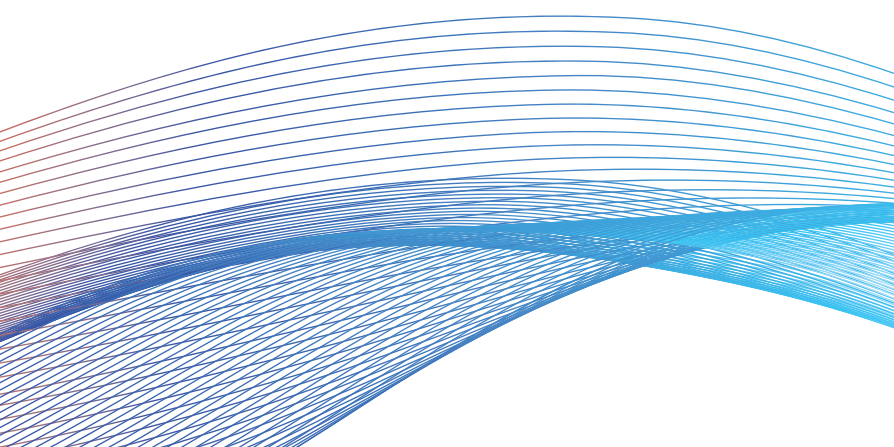

INDEX

INDICE

AIR-OIL HEAT EXCHANGERS BC SCAMBIATORI DI CALORE ARIA-OLIO SERIE BC

DC MOTOR HEAT EXCHANGERS SCAMBIATORI DI CALORE A CORRENTE CONTINUA



AC MOTOR HEAT EXCHANGERS
SCAMBIATORI DI CALORE A CORRENTE ALTERNATA



HYDRAULIC MOTOR HEAT EXCHANGERS
SCAMBIATORI DI CALORE CON MOTORE IDRAULICO







BC 210 12/24V



PURCHASE CODES

BC 210 12/24V without thermo switch	3RBC210I2 3RBC21024
BC 210 12/24V with thermo switch	3RBC210I2T247 3RBC21024T247 3RBC210I2T260 3RBC21024T260

SPARE PARTS

Cooling element	1RO03378
Frame	3CNBC210I
Electric fan 12V	1MCVA14AP7AC
Electric fan 24V	1MCVA14BP7AC
Thermo-switch 47-36 12V IP 67	1TRM 47-36/12V
Thermo-switch 47-36 24V IP 67	1TRM 47-36/24V
Thermo-switch 60-49 12V IP 67	1TRM 60-49/12V
Thermo-switch 60-49 24V IP 67	1TRM 60-49/24V

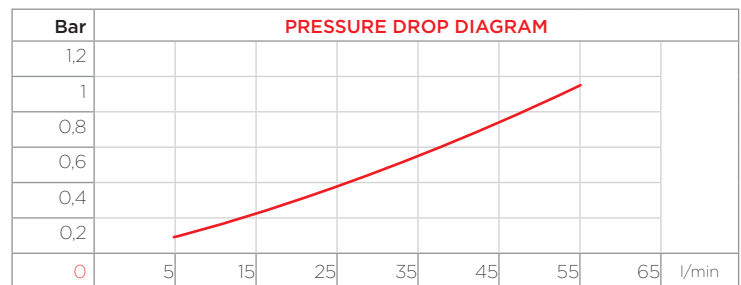
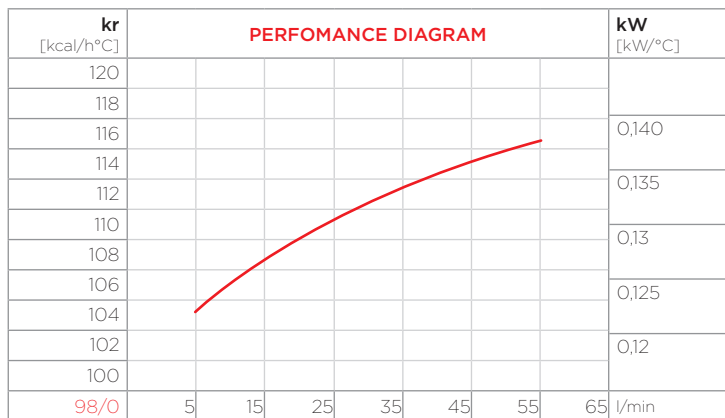

CORRECTION FACTOR							
cSt	22	30	46	68	100	150	220
f	0,6	1	1,5	2,3	3,5	5	7

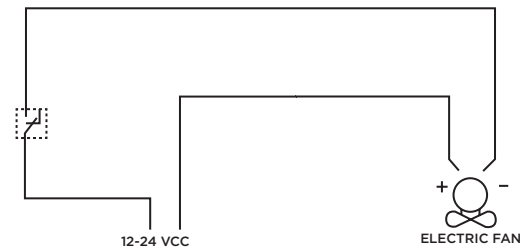

- Dimensions and technical characteristics are not binding

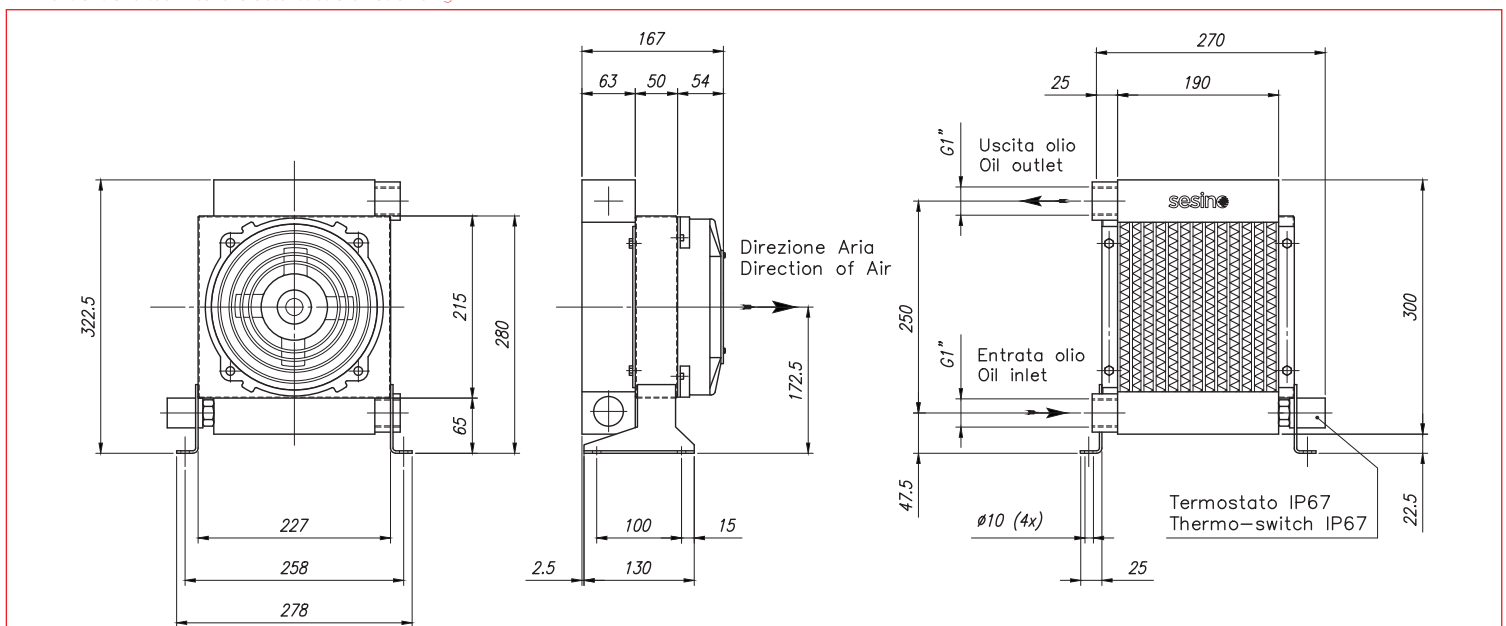

OIL FLOW	VOLTAGE	POWER	CURRENT	AIR FLOW	ELECTRIC PROTECTION	NOISE LEVEL	WEIGHT	ø FAN
l/min	V	W	A	m³/h	IP	dB(A)	kg	mm
10-80	12	65	5.2	500	64	72	5	190
10-80	24	65	2.6	500	64	72	5	190

BC 250 12/24V



PURCHASE CODES

BC 250 12/24V without thermo switch	3RBC25012 3RBC25024
BC 250 12/24V with thermo switch	3RBC25012T247 3RBC25024T247 3RC25012T260 3RBC25024T260

SPARE PARTS

Cooling element	1RO03379
Frame	3CNL300.1
Electric fan 12V	1VNAPL30012C
Electric fan 24V	1VNAPL30024C
Thermo-switch 47-36 12V IP 67	1TRM 47-36/12V
Thermo-switch 47-36 24V IP 67	1TRM 47-36/24V
Thermo-switch 60-49 12V IP 67	1TRM 60-49/12V
Thermo-switch 60-49 24V IP 67	1TRM 60-49/24V

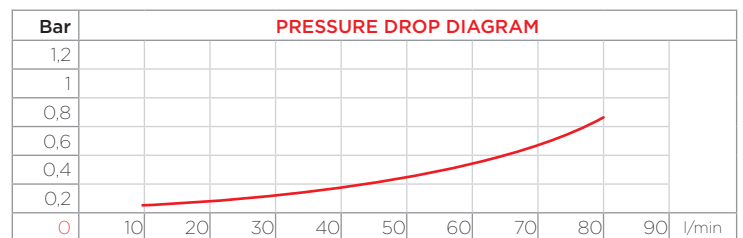
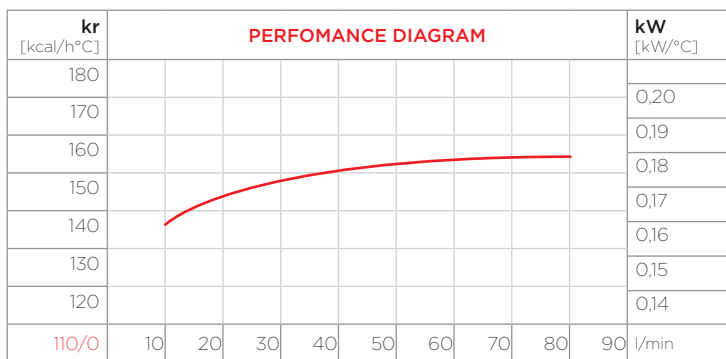

CORRECTION FACTOR

cSt	22	30	46	68	100	150	220
f	0,6	1	1,5	2,3	3,5	5	7

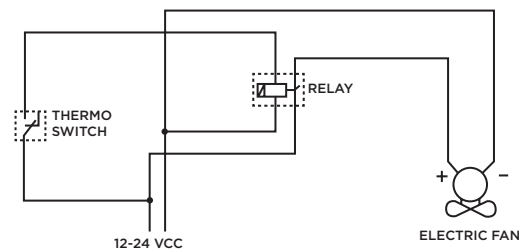

- Dimensions and technical characteristics are not binding

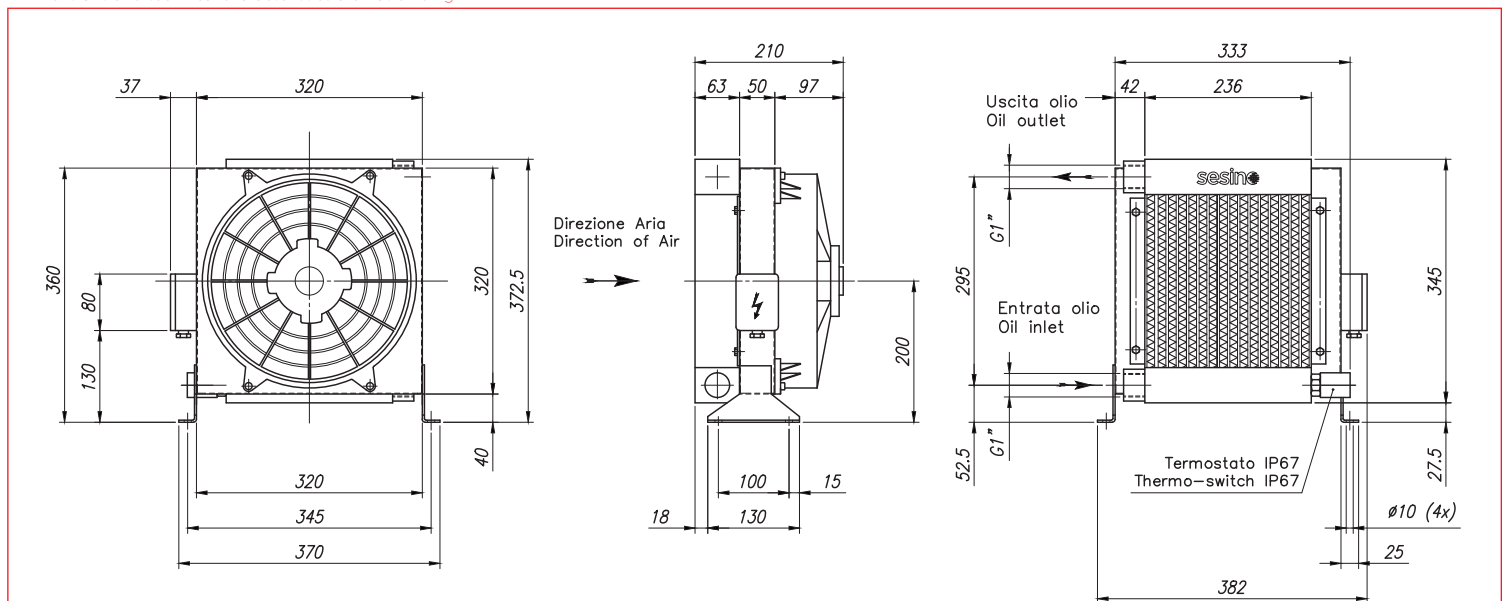

OIL FLOW	VOLTAGE	POWER	CURRENT	AIR FLOW	ELECTRIC PROTECTION	NOISE LEVEL	WEIGHT	ø FAN
l/min	V	W	A	m³/h	IP	dB(A)	kg	mm
20-150	12	190	14,8	1.700	68	79	10	280
20-150	24	190	7,4	1.700	68	79	10	280

BC 250 12/24 BY-PASS



PURCHASE CODES

BC 250 12/24V without thermo switch	3RBC25012BP 3RBC25024BP
BC 250 12/24V with thermo switch	3RBC25012T247BP 3RBC25024T247BP 3RBC25012T260BP 3RBC25024T260BP

SPARE PARTS

Cooling element	1RO03379BP
Frame	3CNL300.1
Electric fan 12V	1VNAPL30012C
Electric fan 24V	1VNAPL30024C
Thermo-switch 47-36 12V IP 67	1TRM 47-36/12V
Thermo-switch 47-36 24V IP 67	1TRM 47-36/24V
Thermo-switch 60-49 12V IP 67	1TRM 60-49/12V
Thermo-switch 60-49 24V IP 67	1TRM 60-49/24V
By-pass	9FTBC

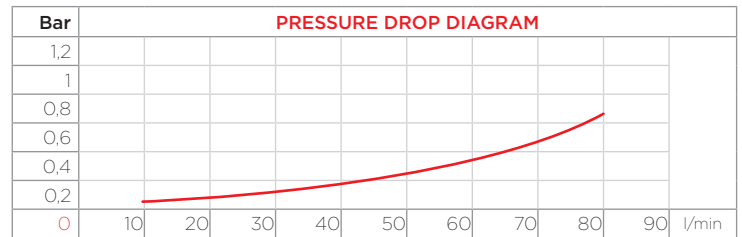
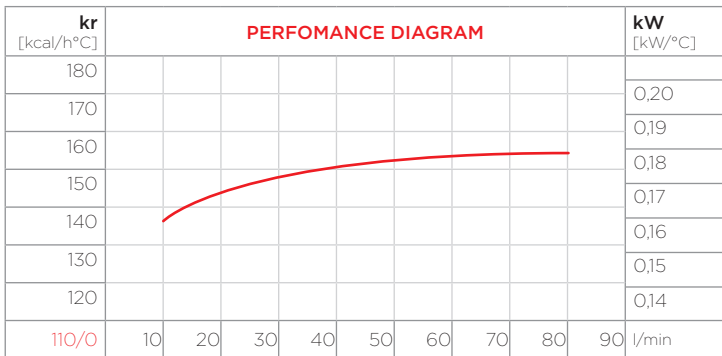

CORRECTION FACTOR

cSt	22	30	46	68	100	150	220
f	0,6	1	1,5	2,3	3,5	5	7

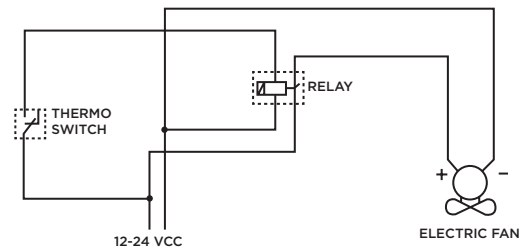

- Dimensions and technical characteristics are not binding

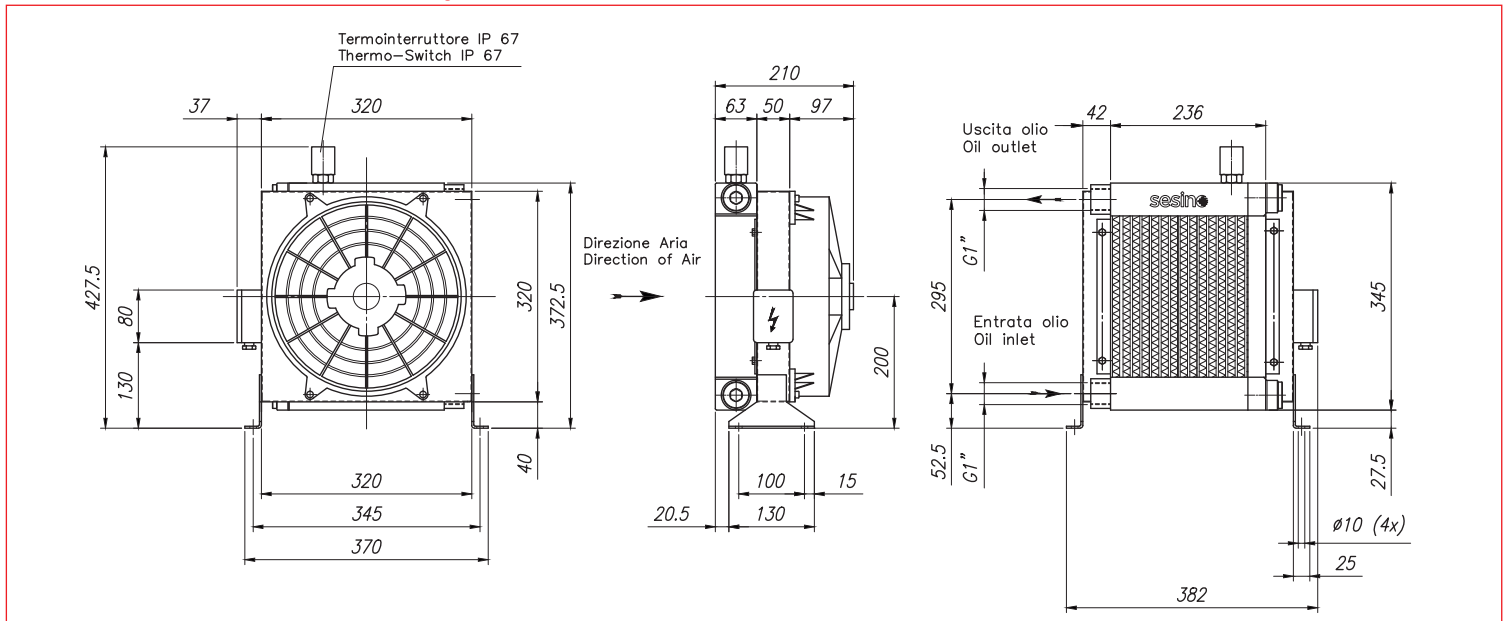

OIL FLOW	VOLTAGE	POWER	CURRENT	AIR FLOW	ELECTRIC PROTECTION	NOISE LEVEL	WEIGHT	ø FAN
l/min	V	W	A	m ³ /h	IP	dB(A)	kg	mm
20-150	12	190	14,8	1.700	68	79	10	280
20-150	24	190	7,4	1.700	68	79	10	280

BC 250/2 12/24V



PURCHASE CODES

BC 250/2 12/24V without thermo switch	3RBC250/212 3RBC250/224
BC 250/2 12/24V with thermo switch	3RBC250/212T247 3RBC250/224T247 3RBC250/212T260 3RBC250/224T260

SPARE PARTS

Cooling element	1RO03380
Frame	3CNL302.1
Electric fan 12V	1VNAPL30012C
Electric fan 24V	1VNAPL30024C
Thermo-switch 47-36 12V IP 67	1TRM 47-36/12V
Thermo-switch 47-36 24V IP 67	1TRM 47-36/24V
Thermo-switch 60-49 12V IP 67	1TRM 60-49/12V
Thermo-switch 60-49 24V IP 67	1TRM 60-49/24V

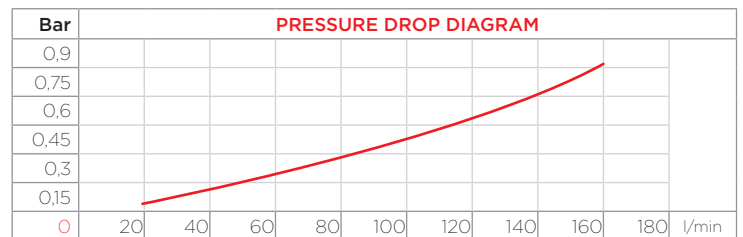
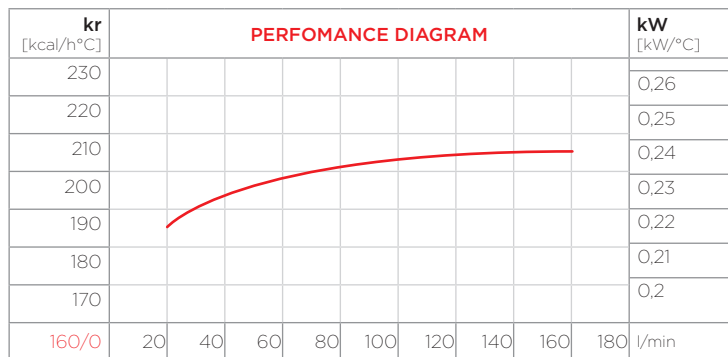

CORRECTION FACTOR

cSt	22	30	46	68	100	150	220
f	0,6	1	1,5	2,3	3,5	5	7

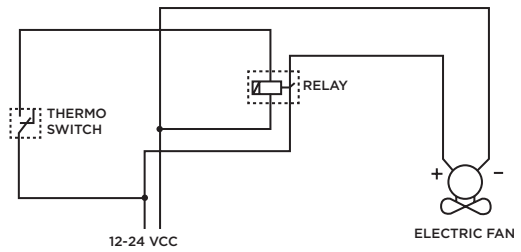

- Dimensions and technical characteristics are not binding

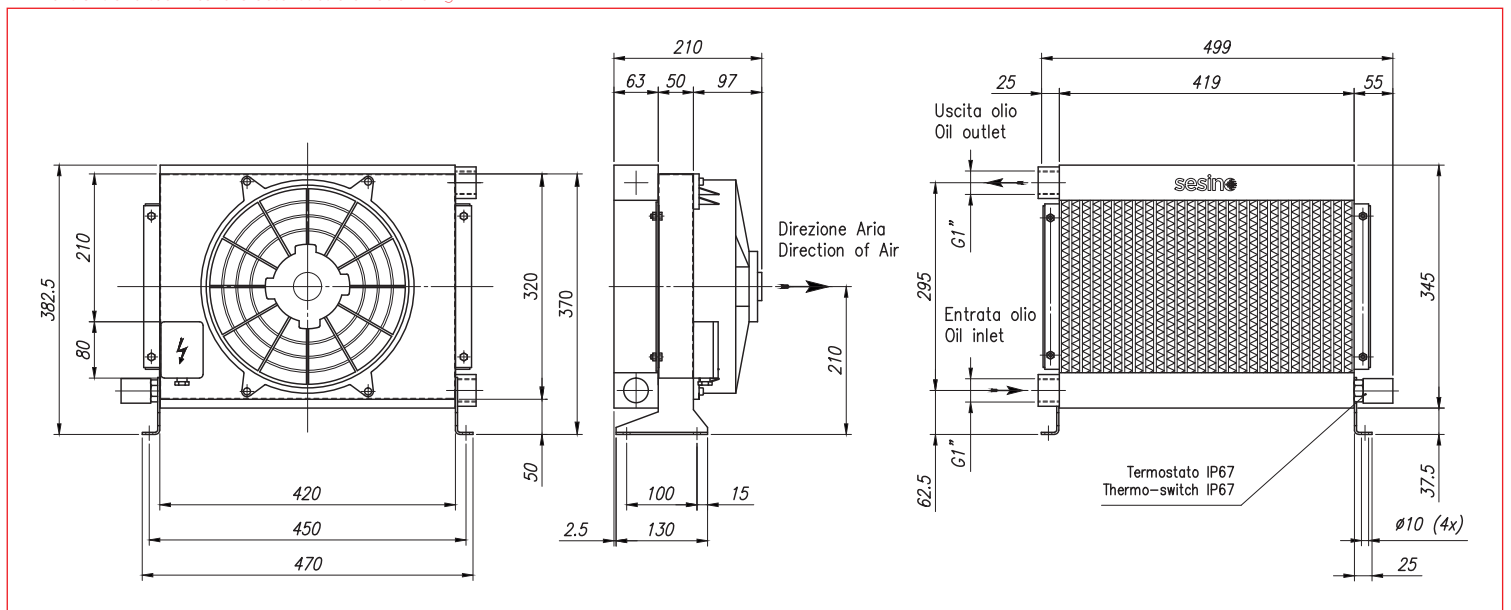

OIL FLOW	VOLTAGE	POWER	CURRENT	AIR FLOW	ELECTRIC PROTECTION	NOISE LEVEL	WEIGHT	ø FAN
l/min	V	W	A	m ³ /h	IP	dB(A)	kg	mm
30-180	12	180	15,0	2.200	68	83	14	280
30-180	24	180	7,5	2.200	68	83	14	280

BC 250/2 12/24 BY-PASS



PURCHASE CODES

BC 250/2 12/24V without thermo switch	3RBC250/212BP 3RBC250/224BP
BC 250/2 12/24V with thermo switch	3RBC250/212T247BP 3RBC250/224T247BP 3RBC250/212T260BP 3RBC250/224T260BP

SPARE PARTS

Cooling element	1RO03380BP
Frame	3CNL3021
Electric fan 12V	1VNAPL30012C
Electric fan 24V	1VNAPL30024C
Thermo-switch 47-36 12V IP 67	1TRM 47-36/12V
Thermo-switch 47-36 24V IP 67	1TRM 47-36/24V
Thermo-switch 60-49 12V IP 67	1TRM 60-49/12V
Thermo-switch 60-49 24V IP 67	1TRM 60-49/24V
By-pass	9FTBC

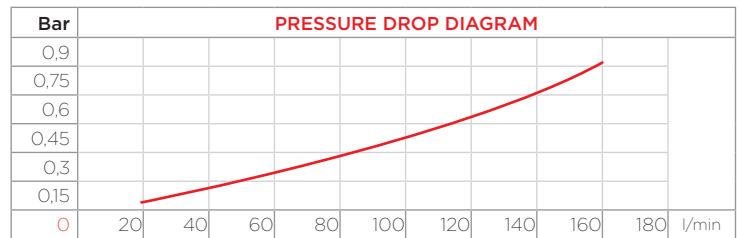
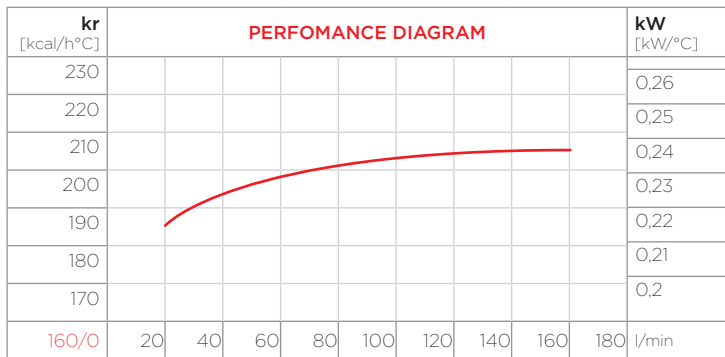

CORRECTION FACTOR

cSt	22	30	46	68	100	150	220
f	0,6	1	1,5	2,3	3,5	5	7

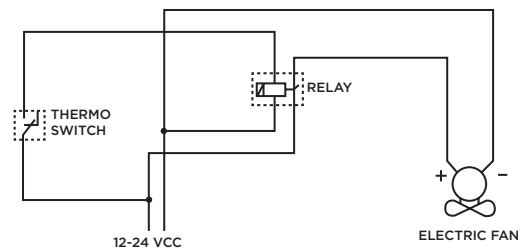

- Dimensions and technical characteristics are not binding

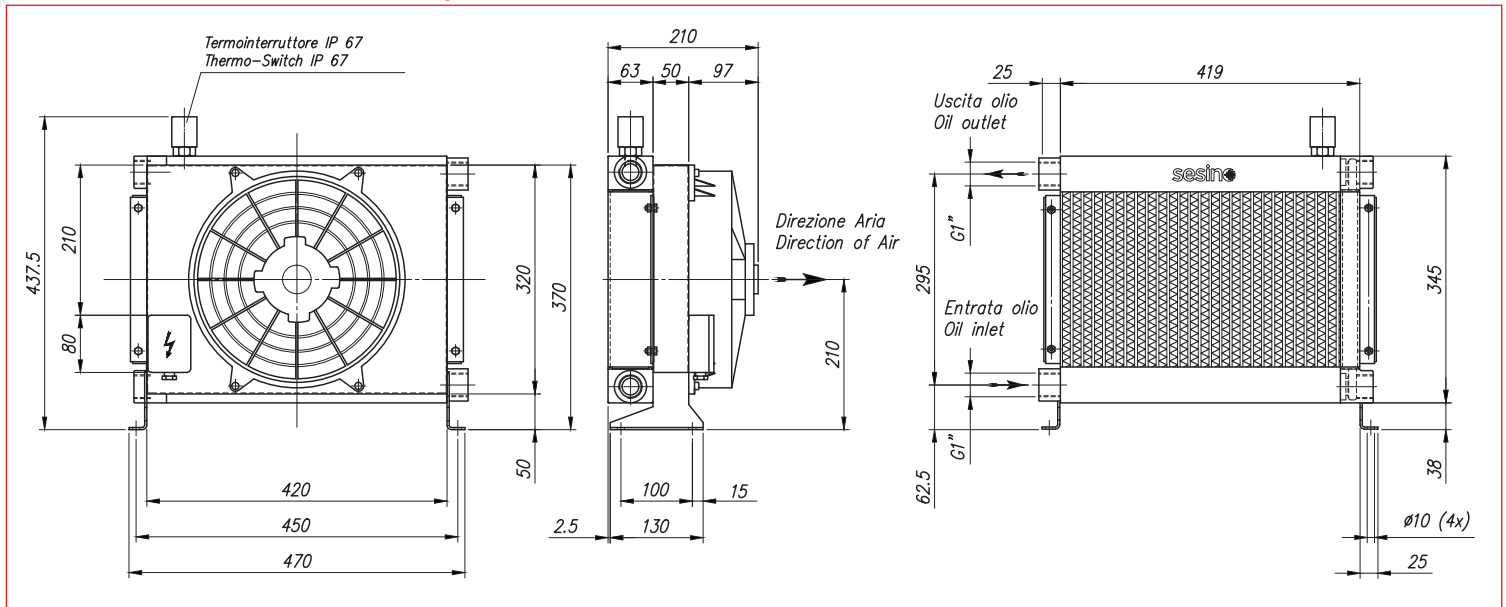

OIL FLOW	VOLTAGE	POWER	CURRENT	AIR FLOW	ELECTRIC PROTECTION	NOISE LEVEL	WEIGHT	Ø FAN
l/min	V	W	A	m³/h	IP	dB(A)	kg	mm
30-180	12	180	15,0	2.200	68	83	14	280
30-180	24	180	7,5	2.200	68	83	14	280

BC 390 12/24V



PURCHASE CODES

BC 390 12/24V without thermo switch	3RBC39012 3RBC39024
BC 390 12/24V with thermo switch	3RBC39012T247 3RBC39024T247 3RBC39012T260 3RBC39024T260

SPARE PARTS

Cooling element	1RO03381
Frame	3CNBC390.1
Electric fan 12V	1MCVA18AP70AC
Electric fan 24V	1VNAPL58024C
Thermo-switch 47-36 12V IP 67	1TRM 47-36/12V
Thermo-switch 47-36 24V IP 67	1TRM 47-36/24V
Thermo-switch 60-49 12V IP 67	1TRM 60-49/12V
Thermo-switch 60-49 24V IP 67	1TRM 60-49/24V

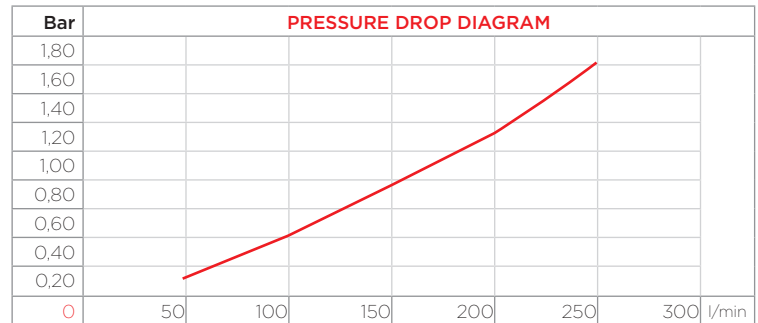
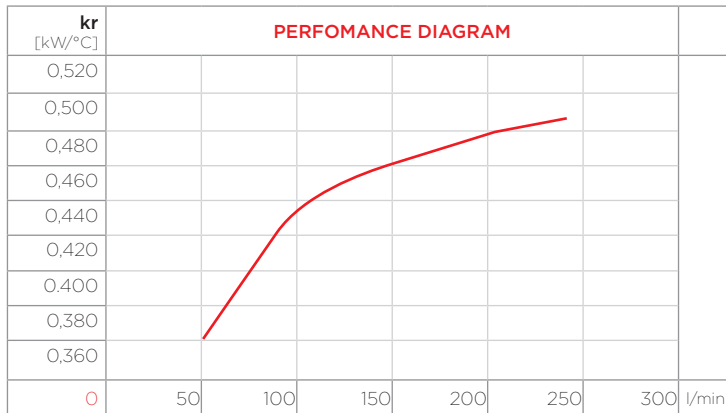

CORRECTION FACTOR

cSt	22	30	46	68	100	150	220
f	0,6	1	1,5	2,3	3,5	5	7

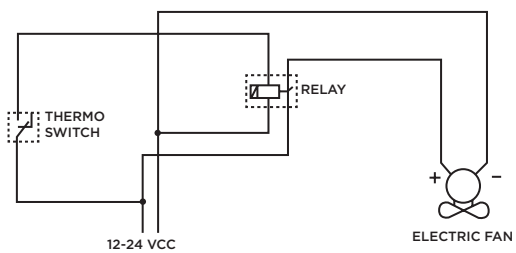

- Dimensions and technical characteristics are not binding

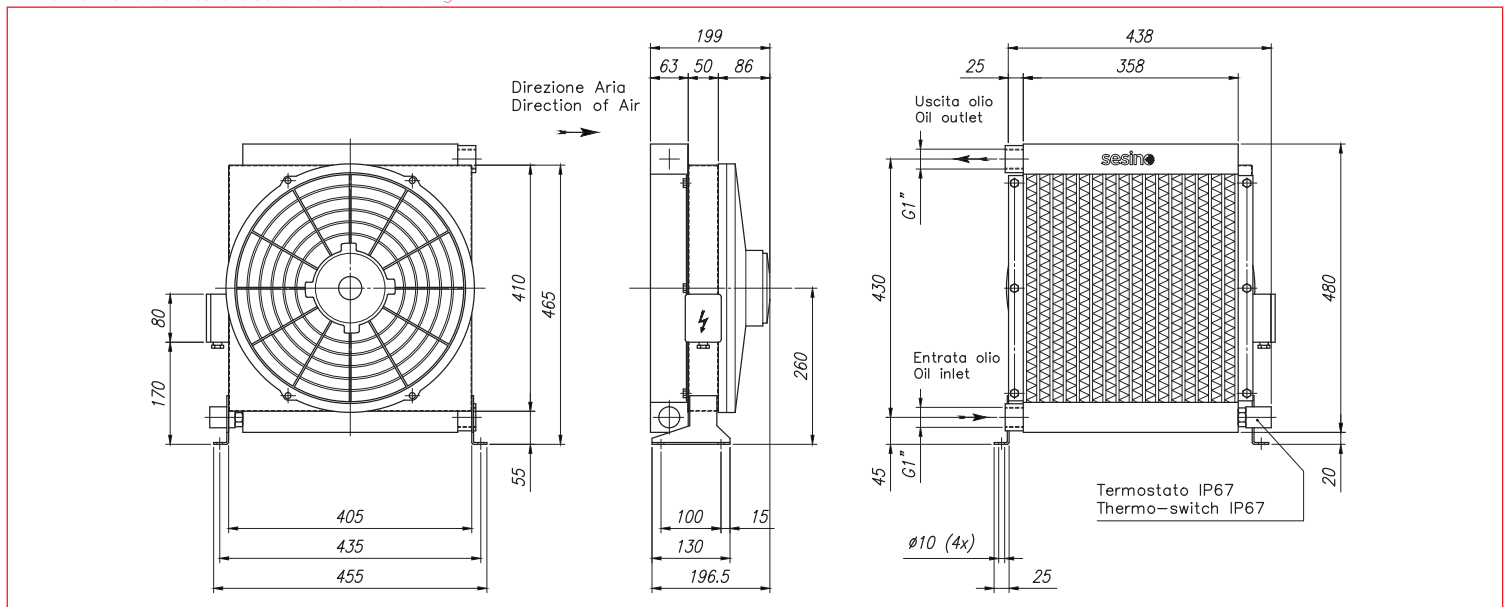

OIL FLOW	VOLTAGE	POWER	CURRENT	AIR FLOW	ELECTRIC PROTECTION	NOISE LEVEL	WEIGHT	ø FAN
l/min	V	W	A	m ³ /h	IP	dB(A)	kg	mm
50-250	12	210	17	2.500	68	82	16	310
50-250	24	210	8,5	2.500	68	82	16	310

BC 390 12/24 BY-PASS

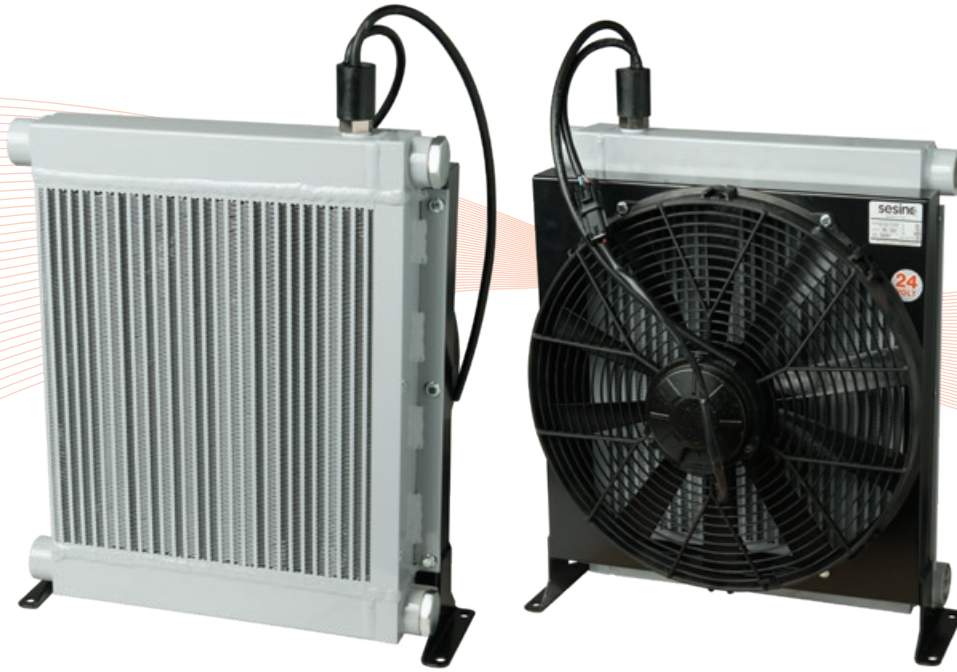

PURCHASE CODES

BC 390 12/24V without thermo switch	3RBC39012BP 3RBC39024BP
BC 390 12/24V with thermo switch	3RBC39012T247BP 3RBC39024T247BP 3RBC39012T260BP 3RBC39024T260BP

SPARE PARTS

Cooling element	1R003381BP
Frame	3CNBC390.1
Electric fan 12V	1MCVA18AP70AC
Electric fan 24V	1VNAPL58024C
Thermo-switch 47-36 12V IP 67	1TRM 47-36/12V
Thermo-switch 47-36 24V IP 67	1TRM 47-36/24V
Thermo-switch 60-49 12V IP 67	1TRM 60-49/12V
Thermo-switch 60-49 24V IP 67	1TRM 60-49/24V
By-pass	9FTBC

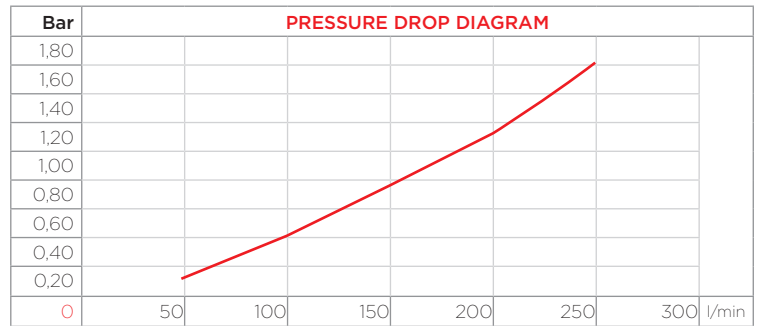
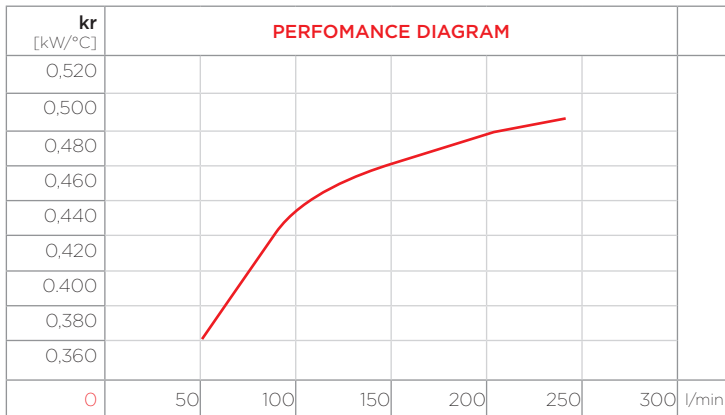

CORRECTION FACTOR

cSt	22	30	46	68	100	150	220
f	0,6	1	1,5	2,3	3,5	5	7

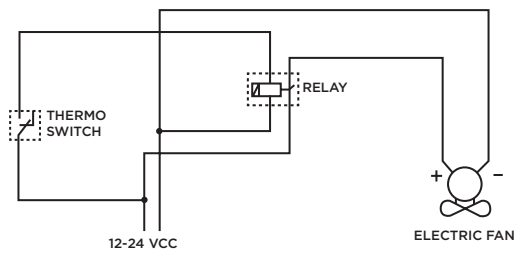

- Dimensions and technical characteristics are not binding

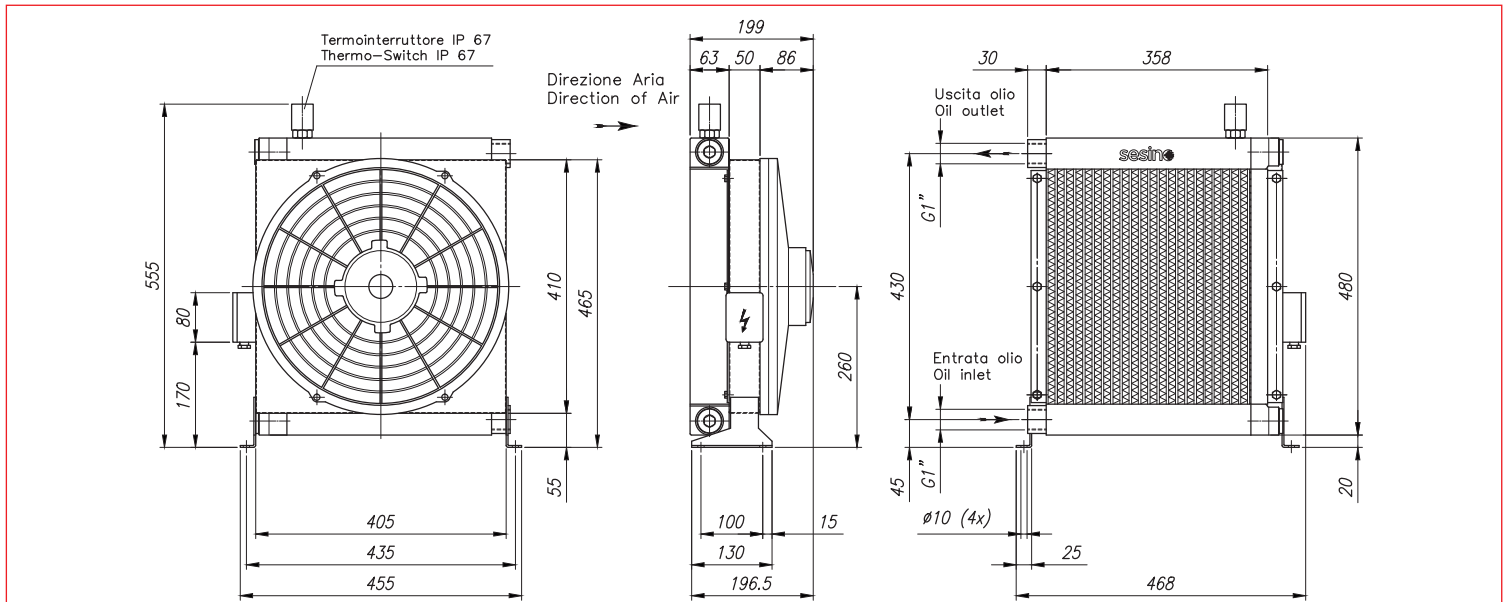

OIL FLOW	VOLTAGE	POWER	CURRENT	AIR FLOW	ELECTRIC PROTECTION	NOISE LEVEL	WEIGHT	ø FAN
l/min	V	W	A	m ³ /h	IP	dB(A)	kg	mm
50-250	12	210	17	2.500	68	82	16	310
50-250	24	210	8,5	2.500	68	82	16	310

BC 390/2 12/24V



PURCHASE CODES

BC 390/2 12/24V without thermo switch	3RBC390/212 3RBC390/224
BC 390/2 12/24V with thermo switch	3RBC390/212T247 3RBC390/224T247 3RBC390/212T260 3RBC390/224T260

SPARE PARTS

Cooling element	1RO03383
Frame	3CNBC390/21
Electric fan 12V	1MCVA18AP70AC
Electric fan 24V	1VNAPL58024C
Thermo-switch 47-36 12V IP 67	1TRM 47-36/12V
Thermo-switch 47-36 24V IP 67	1TRM 47-36/24V
Thermo-switch 60-49 12V IP 67	1TRM 60-49/12V
Thermo-switch 60-49 24V IP 67	1TRM 60-49/24V

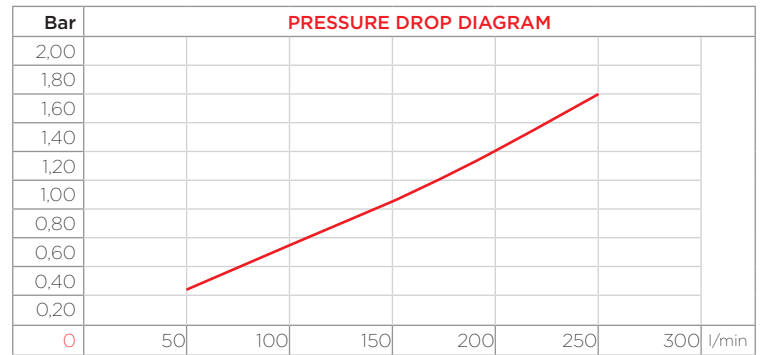
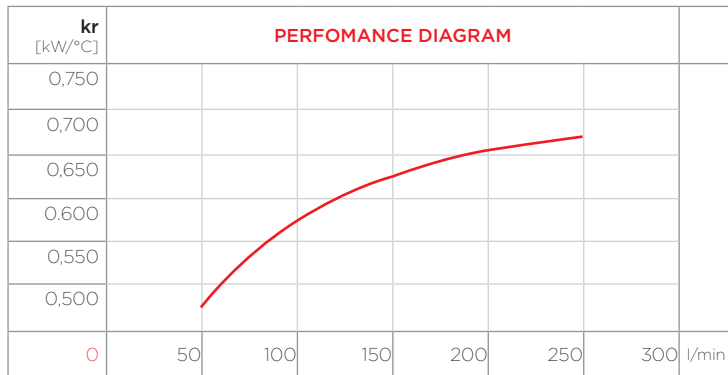

CORRECTION FACTOR

cSt	22	30	46	68	100	150	220
f	0,6	1	1,5	2,3	3,5	5	7

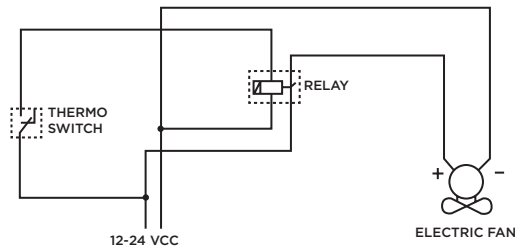

- Dimensions and technical characteristics are not binding

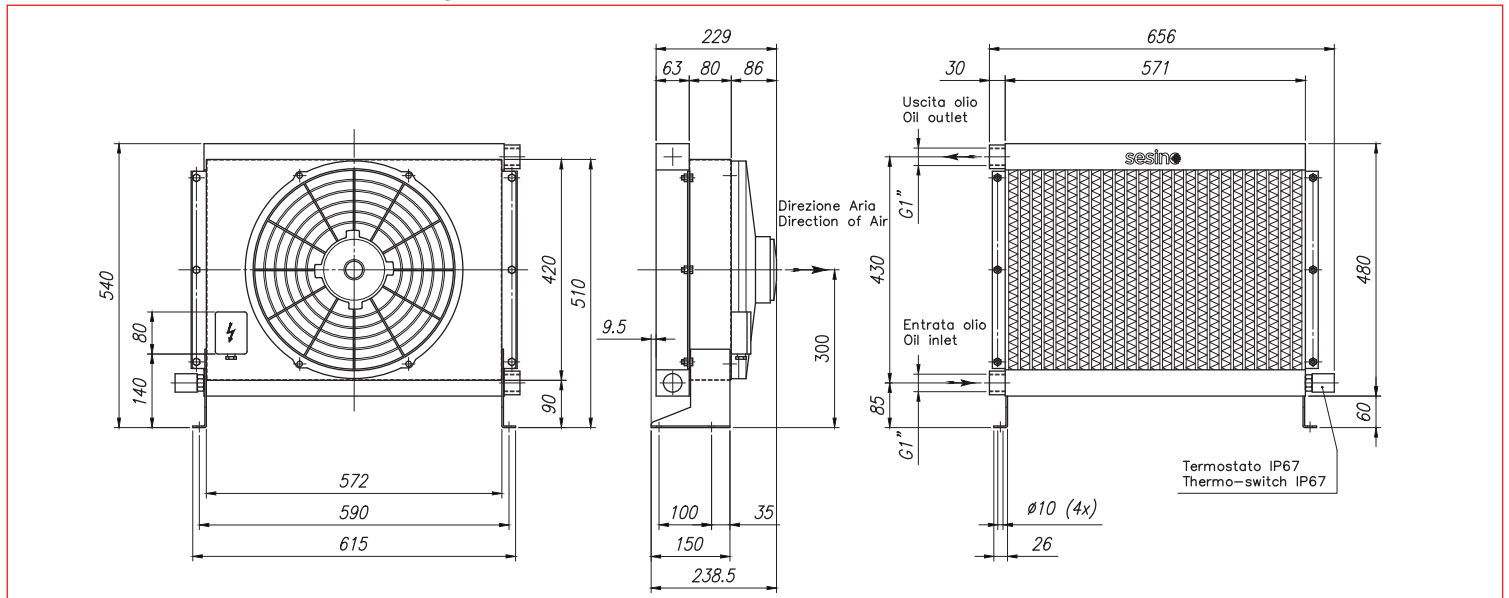

OIL FLOW	VOLTAGE	POWER	CURRENT	AIR FLOW	ELECTRIC PROTECTION	NOISE LEVEL	WEIGHT	ø FAN
l/min	V	W	A	m ³ /h	IP	dB(A)	kg	mm
50-250	12	240	20	2.800	68	85	25	380
50-250	24	240	10	2.800	68	85	25	380

BC 390/2 12/24 BY-PASS



PURCHASE CODES

BC 390/2 12/24V without thermo switch	3RBC390/212BP 3RBC390/224BP
BC 390/2 12/24V with thermo switch	3RBC390/212T247BP 3RBC390/224T247BP 3RBC390/212T260BP 3RBC390/224T260BP

SPARE PARTS

Cooling element	1RO03383BP
Frame	3CNBC390/2.1
Electric fan 12V	1MCVA18AP70AC
Electric fan 24V	1VNAPL58024C
Thermo-switch 47-36 12V IP 67	1TRM 47-36/12V
Thermo-switch 47-36 24V IP 67	1TRM 47-36/24V
Thermo-switch 60-49 12V IP 67	1TRM 60-49/12V
Thermo-switch 60-49 24V IP 67	1TRM 60-49/24V
By-pass	9FTBC

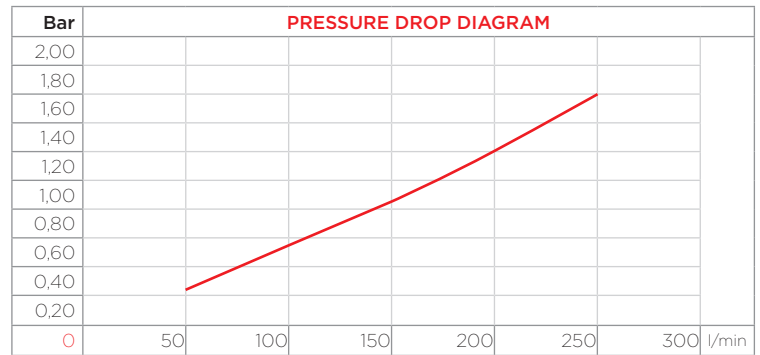
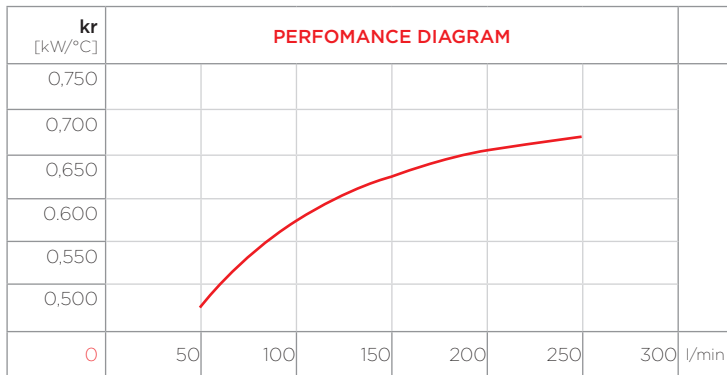

CORRECTION FACTOR

cSt	22	30	46	68	100	150	220
f	0.6	1	1.5	2.3	3.5	5	7

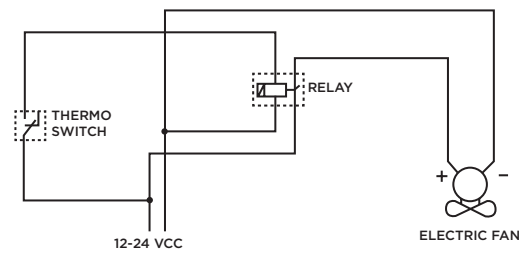

- Dimensions and technical characteristics are not binding

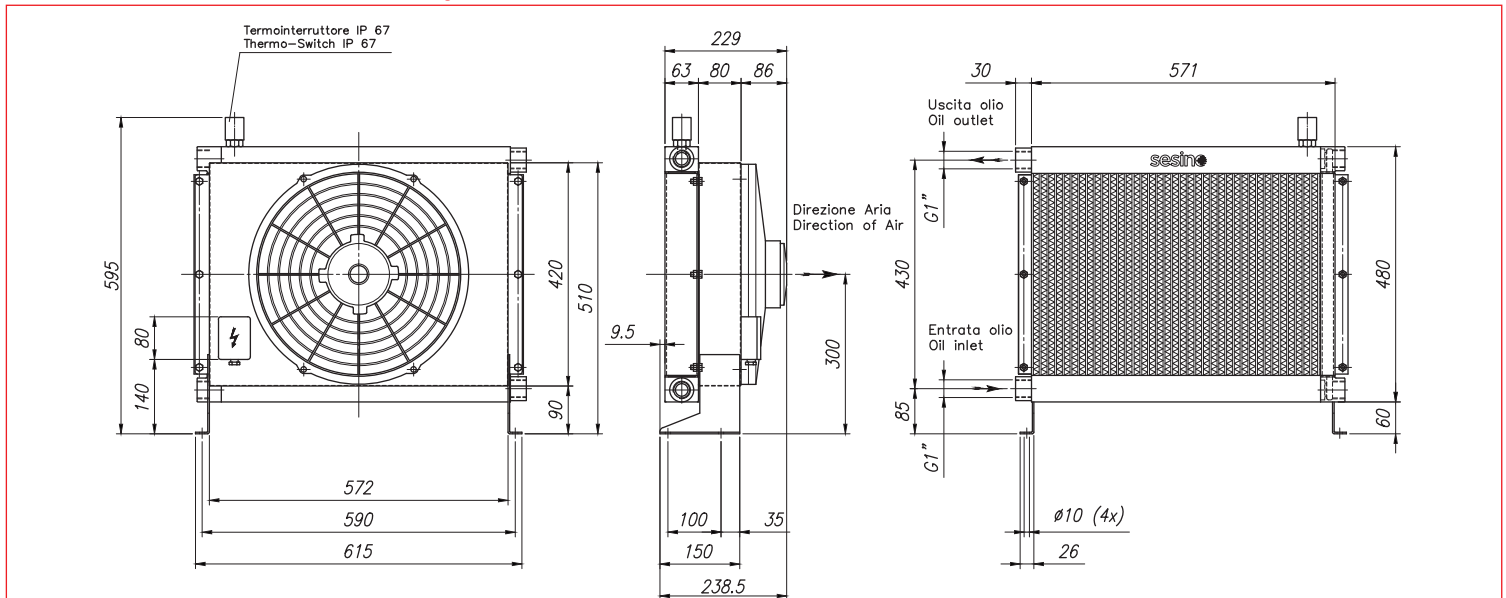

OIL FLOW	VOLTAGE	POWER	CURRENT	AIR FLOW	ELECTRIC PROTECTION	NOISE LEVEL	WEIGHT	Ø FAN
l/min	V	W	A	m ³ /h	IP	dB(A)	kg	mm
50-250	12	240	20	2.800	68	85	25	380
50-250	24	240	10	2.800	68	85	25	380

BC 390/3 12/24 BY-PASS

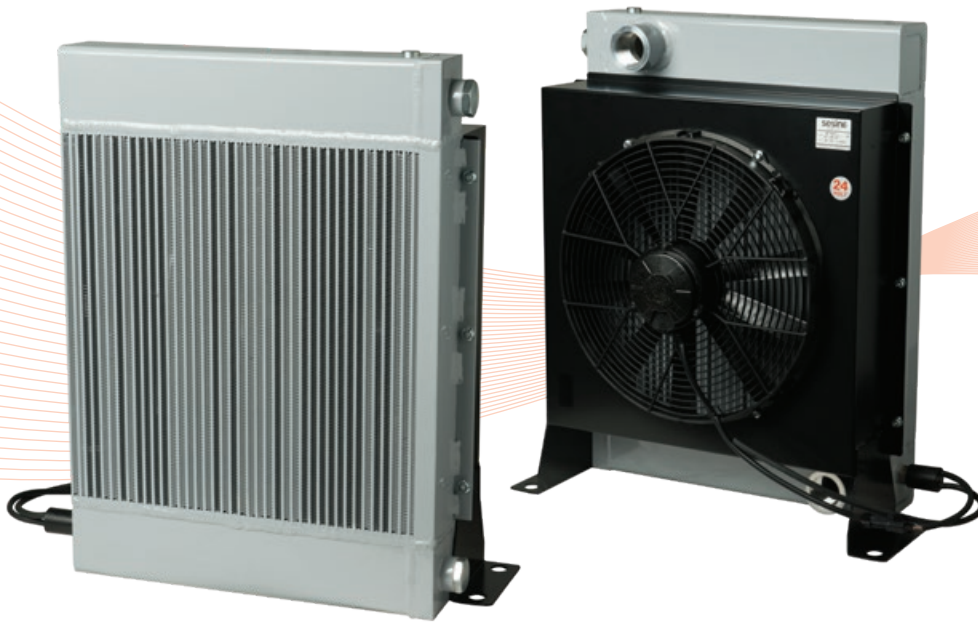

PURCHASE CODES

BC 390/3 12/24V without thermo switch	3RBC390/312BP 3RB- C390/324BP
BC 390/3 12/24V with thermo switch	3RBC390/312T247BP 3RBC390/324T247BP 3RBC390/312T260BP 3RBC390/324T260BP

SPARE PARTS

Cooling element	1RO14494BP
Frame	3CNBC390/3.1
Electric fan 12V	1MCVA18AP70AC
Electric fan 24V	1VNAPL58024C
Thermo-switch 47-36 12V IP 67	1TRM 47-36/12V
Thermo-switch 47-36 24V IP 67	1TRM 47-36/24V
Thermo-switch 60-49 12V IP 67	1TRM 60-49/12V
Thermo-switch 60-49 24V IP 67	1TRM 60-49/24V
By-pass	9FTBC

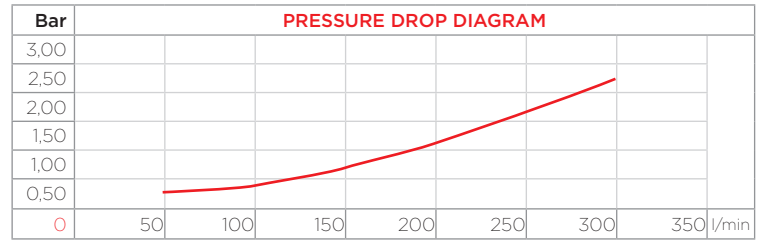
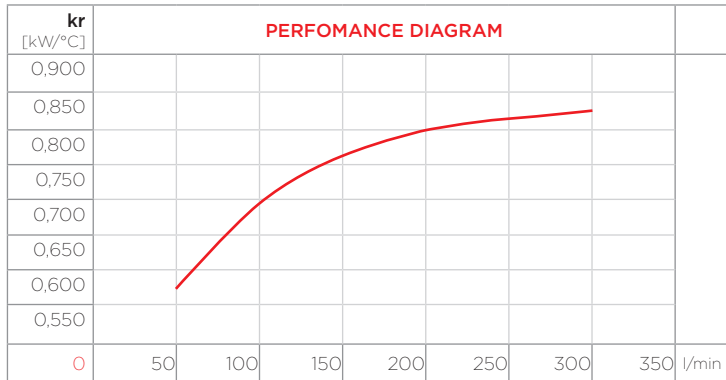

CORRECTION FACTOR

cSt	22	30	46	68	100	150	220
f	0.6	1	1.5	2.3	3.5	5	7

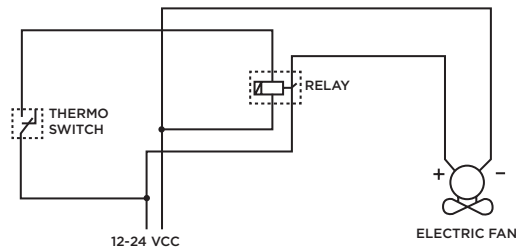

- Dimensions and technical characteristics are not binding

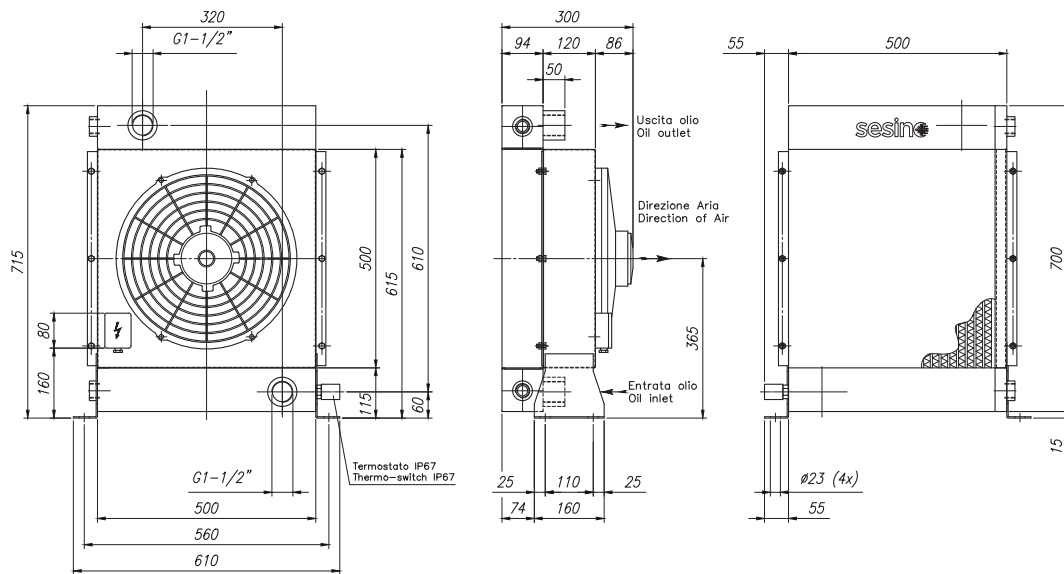

OIL FLOW	VOLTAGE	POWER	CURRENT	AIR FLOW	ELECTRIC PROTECTION	NOISE LEVEL	WEIGHT	ø FAN
l/min	V	W	A	m ³ /h	IP	dB(A)	kg	mm
50-300	12	240	20	2.900	68	85	33	380
50-300	24	240	10	2.900	68	85	33	380

BC 210 AC



PURCHASE CODES

BC 210 single phase without thermo switch	3RBC210
BC 210 single phase with thermo switch	3RBC210T247 3RBC210T260
BC 210 three phase without thermo switch	3RBC21038
BC 210 three phase with thermo switch	3RBC21038T247 3RBC21038T260

SPARE PARTS

Cooling element	1RO03378
Frame	3CNBC210M/T1
Electric fan for BC 210 single phase	1VNA2E200.1
Electric fan for BC 210 three phase	1VNA2D200
Thermo-switch 47-36 IP 65	1TRM 47-36
Thermo-switch 60-49 IP 65	1TRM 60-49

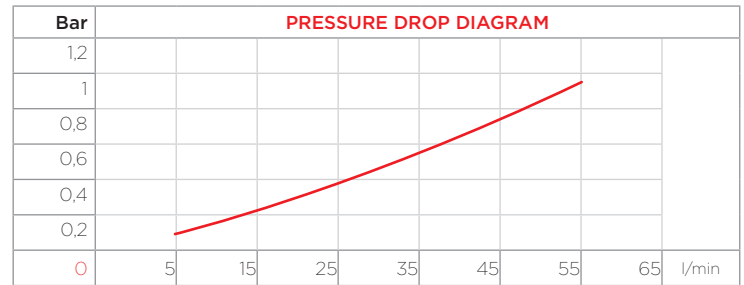
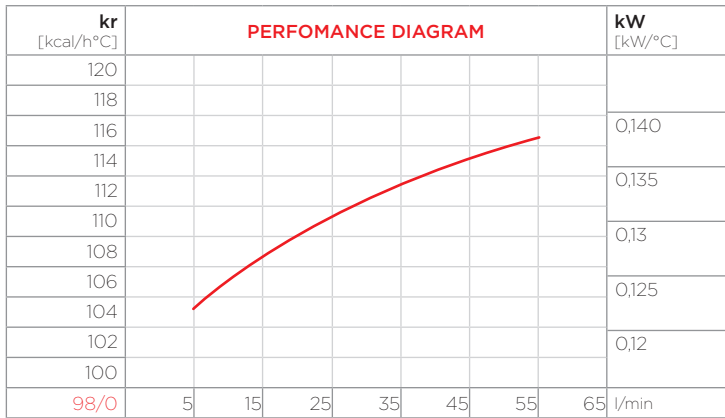

CORRECTION FACTOR

cSt	22	30	46	68	100	150	220
f	0,6	1	1,5	2,3	3,5	5	7

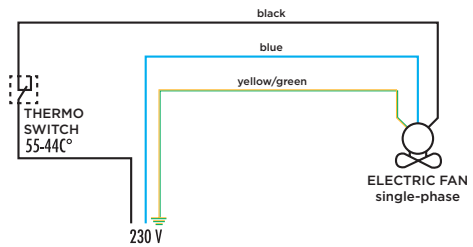

- Dimensions and technical characteristics are not binding

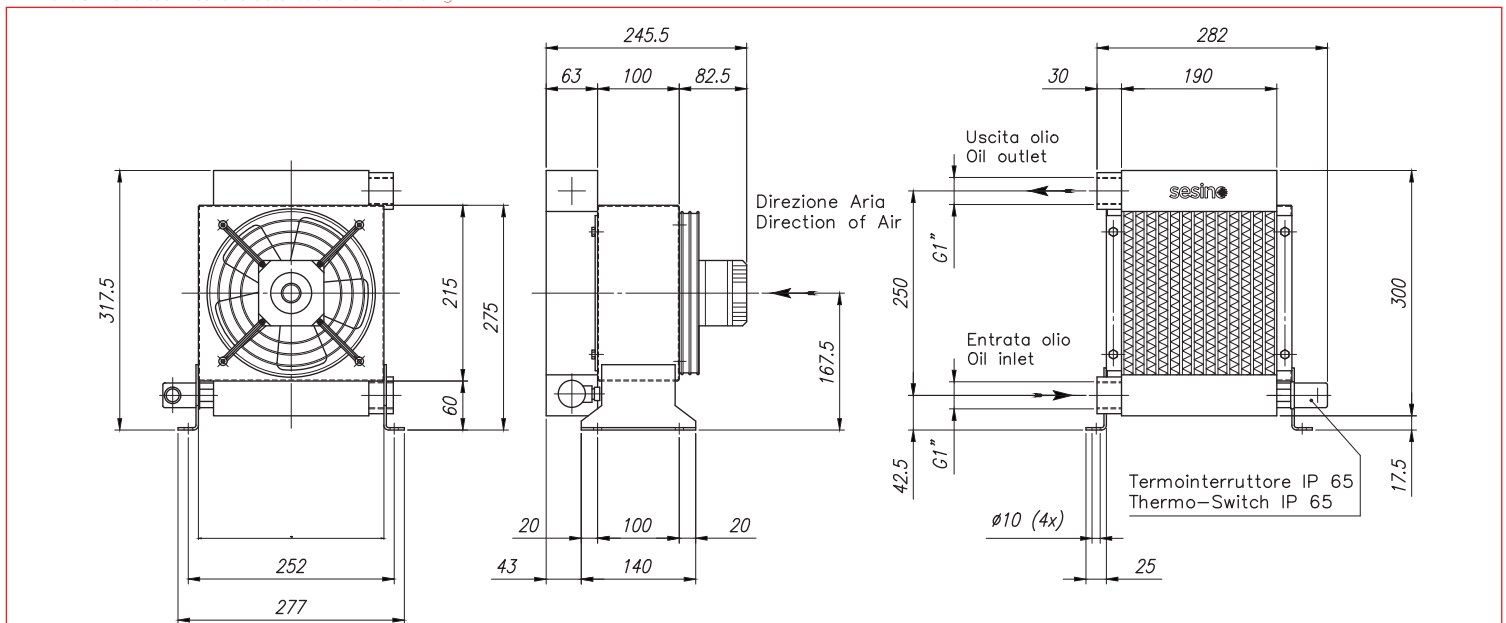

OIL FLOW	VOLTAGE	FREQUENCY	POWER	CURRENT	AIR FLOW	PROTECTION	NOISE LEVEL	WEIGHT	ø FAN
l/min	V	hz	W	A	m ³ /h	IP	dB(A)	kg	mm
10-80	230/240	50/60	18/62	0,27	630	54	55	6	200
10-80	400	50/60	68/70	0,17/0,13	630	54	55	6	200

BC 250 AC



PURCHASE CODES

BC 250 single phase without thermo switch	3RBC250
BC 250 single phase with thermo switch	3RBC250T247 3RBC250T260
BC 250 three phase without thermo switch	3RBC25038
BC 250 three phase with thermo switch	3RBC25038T247 3RBC25038T260

SPARE PARTS

Cooling element	1RO03379
Frame	3CNBC250M/T1
Electric fan for BC 250 single phase	1VNA2E250G
Electric fan for BC 250 three phase	1VNA2D250.2
Thermo-switch 47-36 IP 65	1TRM 47-36
Thermo-switch 60-49 IP 65	1TRM 60-49

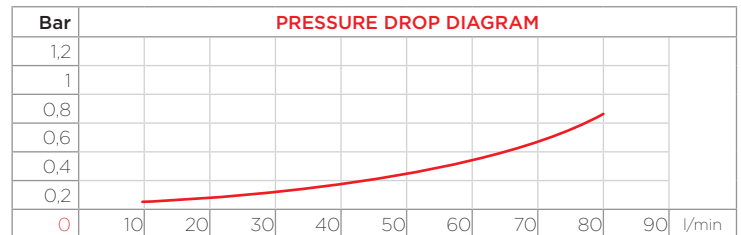
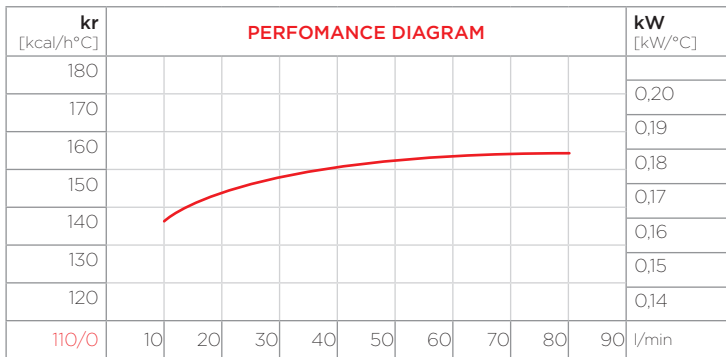

CORRECTION FACTOR

cSt	22	30	46	68	100	150	220
f	0,6	1	1,5	2,3	3,5	5	7

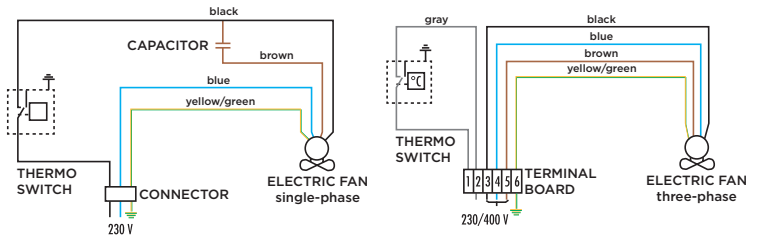

- Dimensions and technical characteristics are not binding

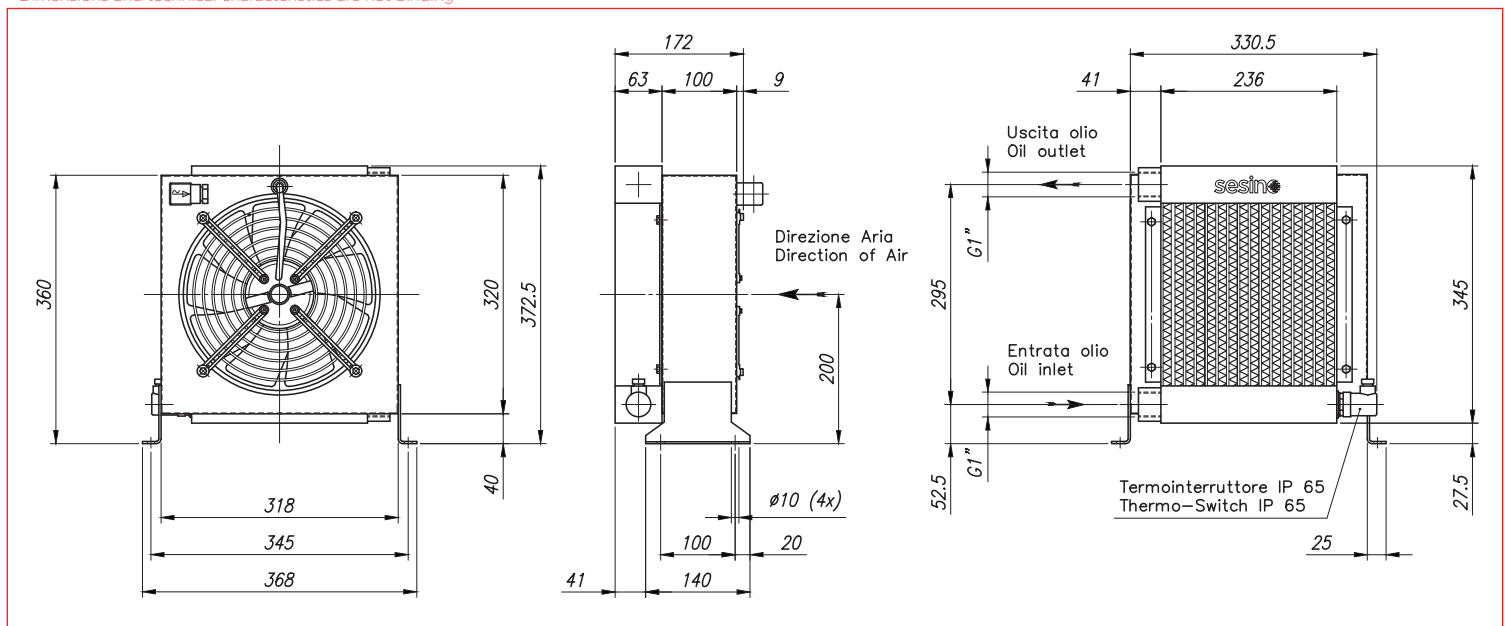

OIL FLOW	VOLTAGE	FREQUENCY	POWER	CURRENT	AIR FLOW	PROTECTION	NOISE LEVEL	WEIGHT	Ø FAN
l/min	V	hz	W	A	m ³ /h	IP	dB(A)	kg	mm
20-150	230	50/60	115/150	0,51/0,66	910	54	74	13	250
20-150	400	50/60	100/140	0,20/0,23	950	54	73	13	250

BC 250 AC BY-PASS

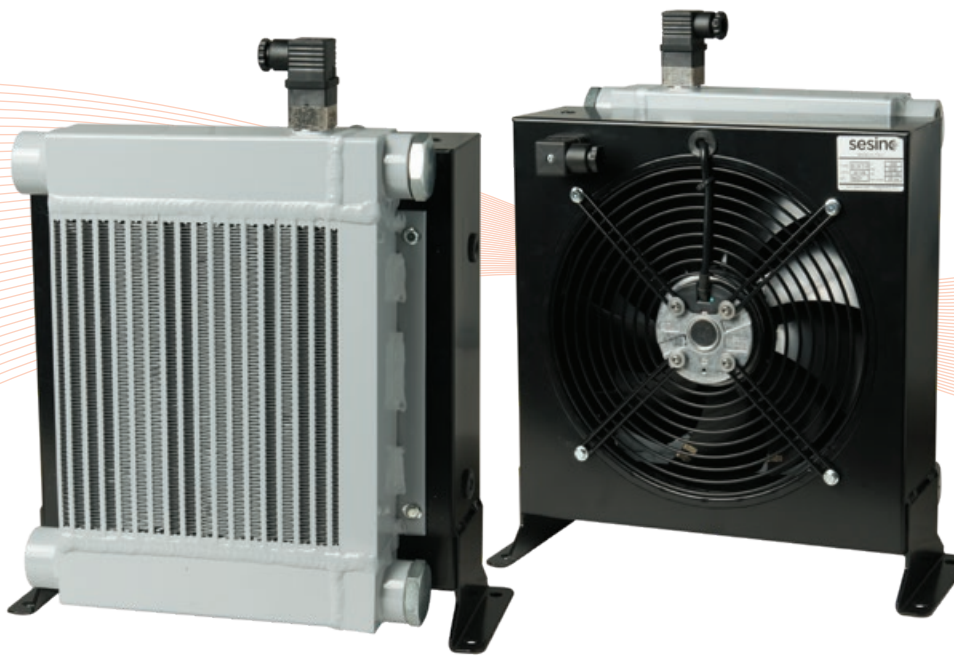

PURCHASE CODES

BC 250 single phase without thermo switch	3RBC250BP
BC 250 single phase with thermo switch	3RBC250T247BP 3RBC250T260BP
BC 250 three phase without thermo switch	3RBC25038BP
BC 250 three phase with thermo switch	3RBC25038T247BP 3RBC25038T260BP

SPARE PARTS

Cooling element	1RO03379BP
Frame	3CNBC250M/T1
Electric fan for BC 250 single phase	1VNA2E250G
Electric fan for BC 250 three phase	1VNA2D250.2
Thermo-switch 47-36 IP 65	1TRM 47-36
Thermo-switch 60-49 IP 65	1TRM 60-49
By-pass	9FTBC

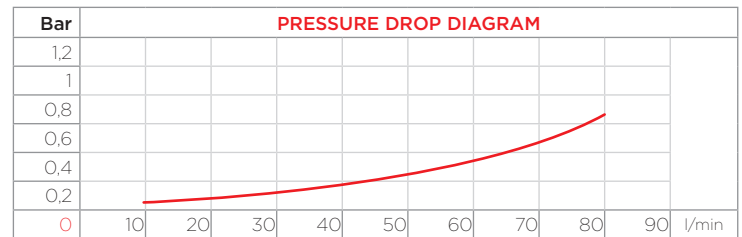
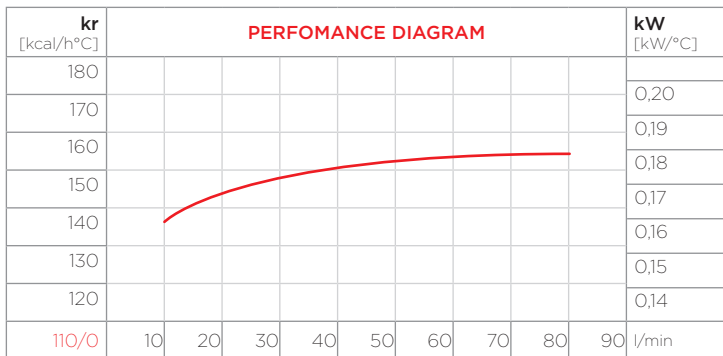

CORRECTION FACTOR

cSt	22	30	46	68	100	150	220
f	0,6	1	1,5	2,3	3,5	5	7

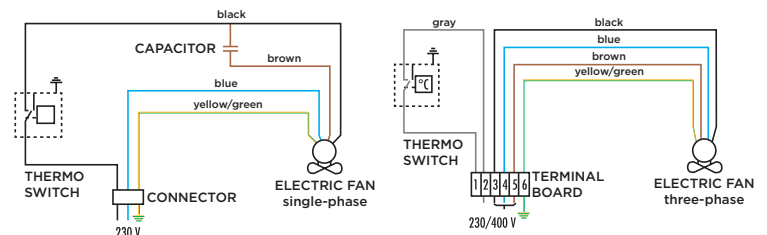

- Dimensions and technical characteristics are not binding

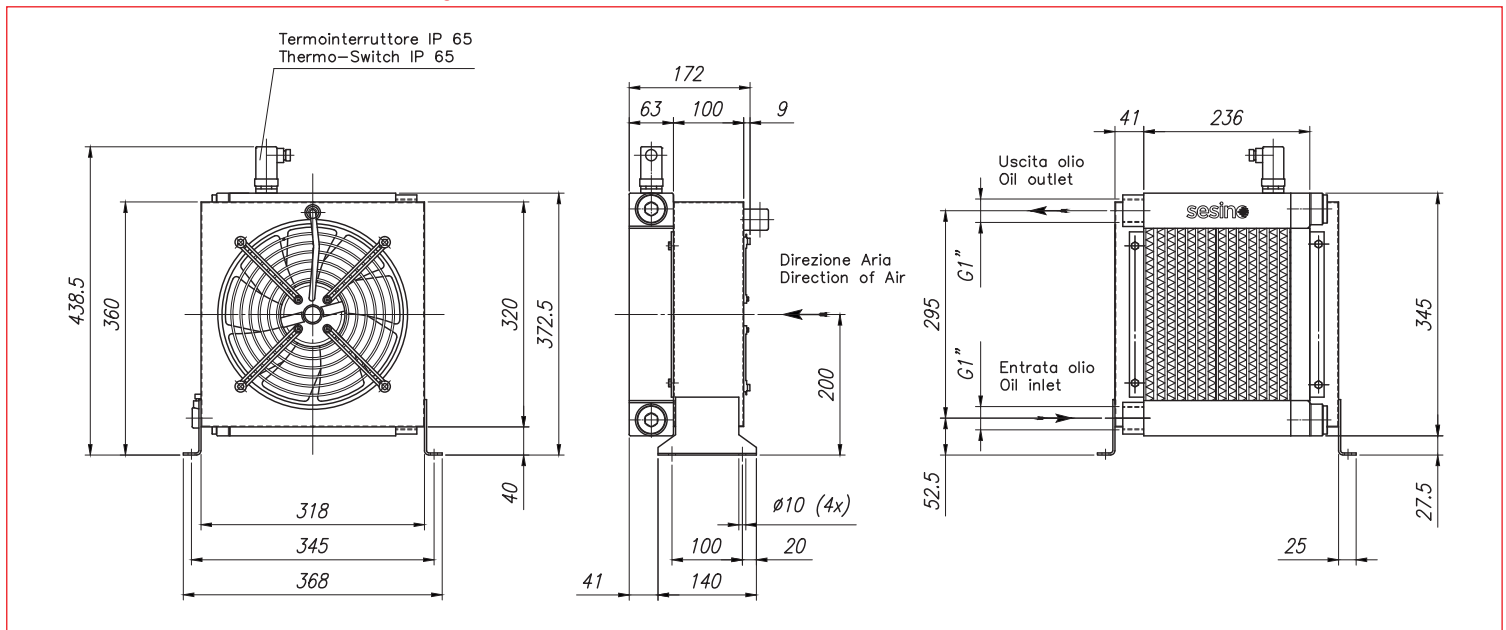

OIL FLOW	VOLTAGE	FREQUENCY	POWER	CURRENT	AIR FLOW	PROTECTION	NOISE LEVEL	WEIGHT	Ø FAN
l/min	V	hz	W	A	m ³ /h	IP	dB(A)	kg	mm
20-150	230	50/60	115/150	0,51/0,66	910	54	74	13	250
20-150	400	50/60	100/140	0,20/0,23	950	54	73	13	250

BC 250/2 AC



PURCHASE CODES

BC 250/2 single phase without thermo switch	3RBC250/2
BC 250/2 single phase with thermo switch	3RBC250/2T247 3RBC250/2T260
BC 250/2 three phase without thermo switch	3RBC250/238
BC 250/2 three phase with thermo switch	3RBC250/238T247 3RBC250/238T260

SPARE PARTS

Cooling element	1RO03380
Frame	3CNBC250/2M/T1
Electric fan for BC 250/2 single phase	1VNA2E250G
Electric fan for BC 250/2 three phase	1VNA2D250.2
Thermo-switch 47-36 IP 65	1TRM 47-36
Thermo-switch 60-49 IP 65	1TRM 60-49

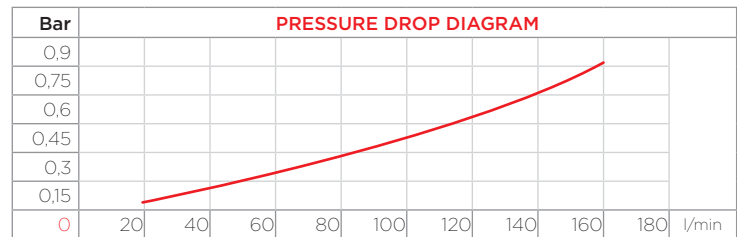
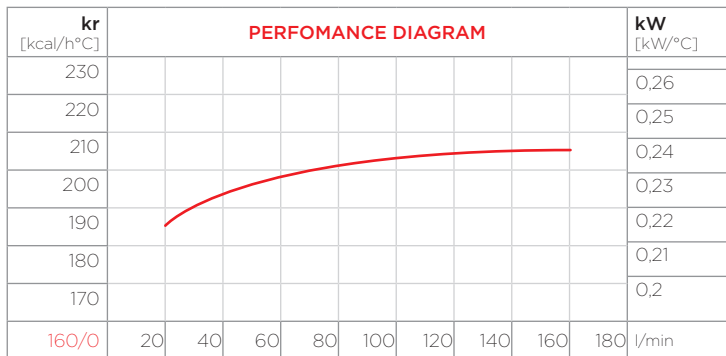

CORRECTION FACTOR

cSt	22	30	46	68	100	150	220
f	0,6	1	1,5	2,3	3,5	5	7

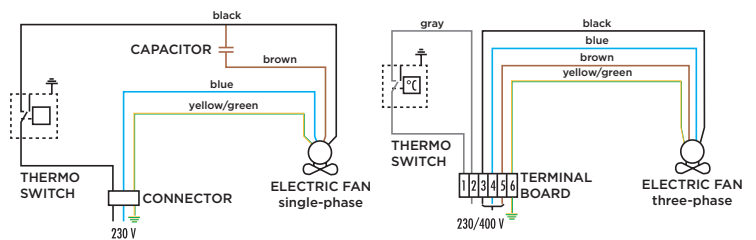

- Dimensions and technical characteristics are not binding

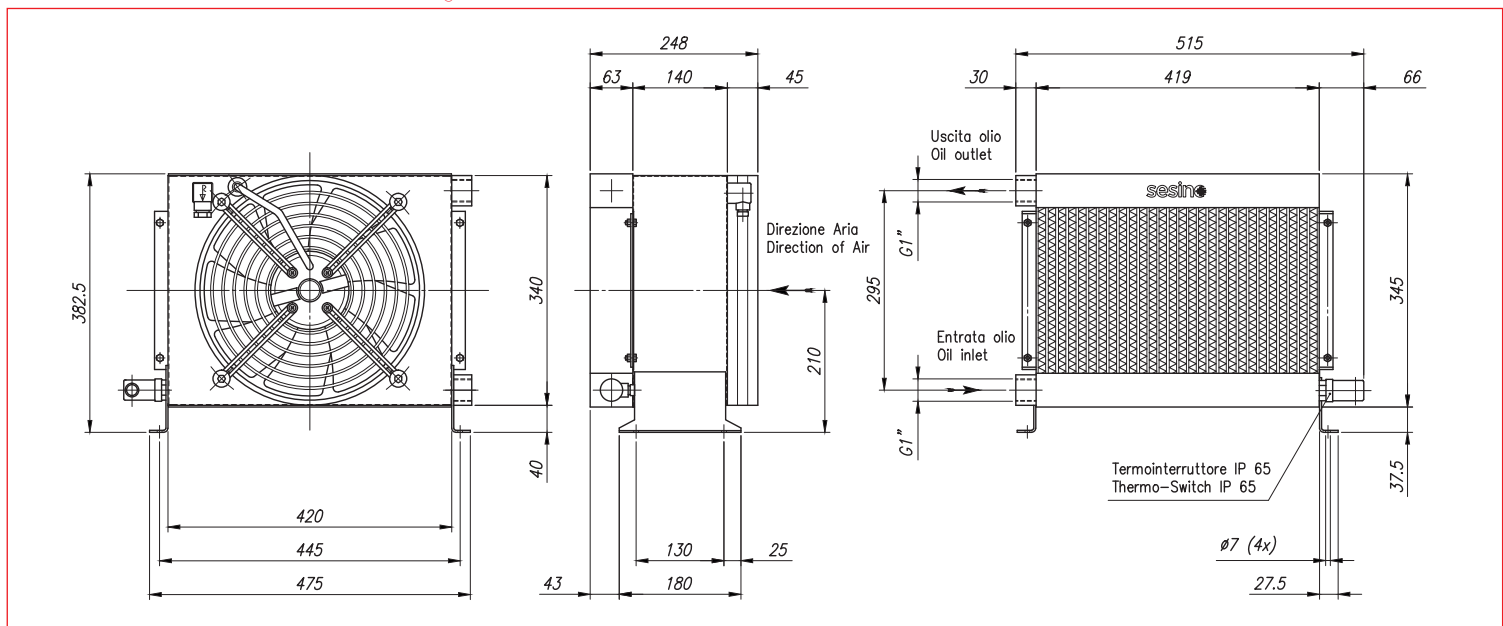

OIL FLOW	VOLTAGE	FREQUENCY	POWER	CURRENT	AIR FLOW	PROTECTION	NOISE LEVEL	WEIGHT	Ø FAN
l/min	V	hz	W	A	m ³ /h	IP	dB(A)	kg	mm
30-180	230	50/60	115/150	0,51/0,66	1.300	54	75	17	250
30-180	400	50/60	100/140	0,20/0,23	1.300	54	73	12	250

BC 250/2 AC BY-PASS



PURCHASE CODES

BC 250/2 single phase without thermo switch	3RBC250/2BP
BC 250/2 single phase with thermo switch	3RBC250/2T247BP 3RBC250/2T260BP
BC 250/2 three phase without thermo switch	3RBC250/238BP
BC 250/2 three phase with thermo switch	3RBC250/238T247BP 3RBC250/238T260BP

SPARE PARTS

Cooling element	1RO03380BP
Frame	3CNBC250/2M/T.1
Electric fan for BC 250/2 single phase	1VNA2E250G
Electric fan for BC 250/2 three phase	1VNA2D250.2
Thermo-switch 47-36 IP 65	1TRM 47-36
Thermo-switch 60-49 IP 65	1TRM 60-49
By-pass	9FTBC

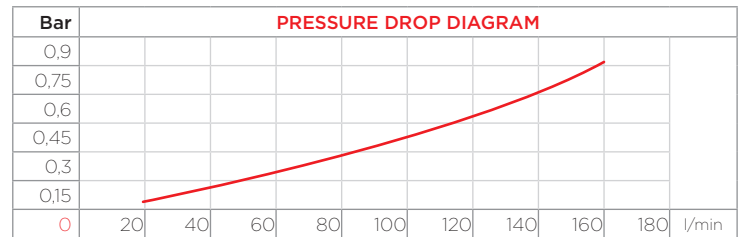
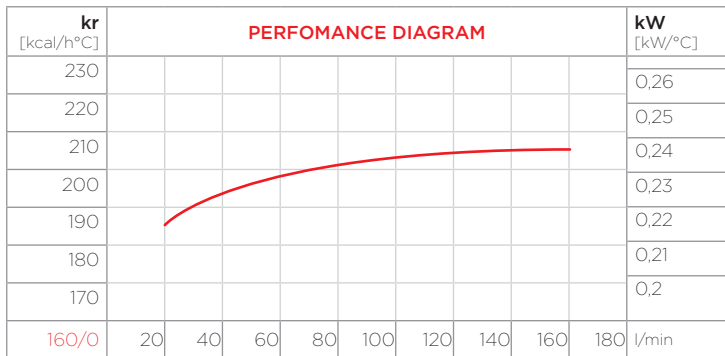

CORRECTION FACTOR

cSt	22	30	46	68	100	150	220
f	0,6	1	1,5	2,3	3,5	5	7

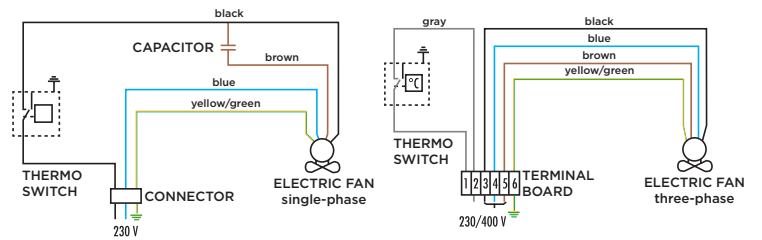

- Dimensions and technical characteristics are not binding

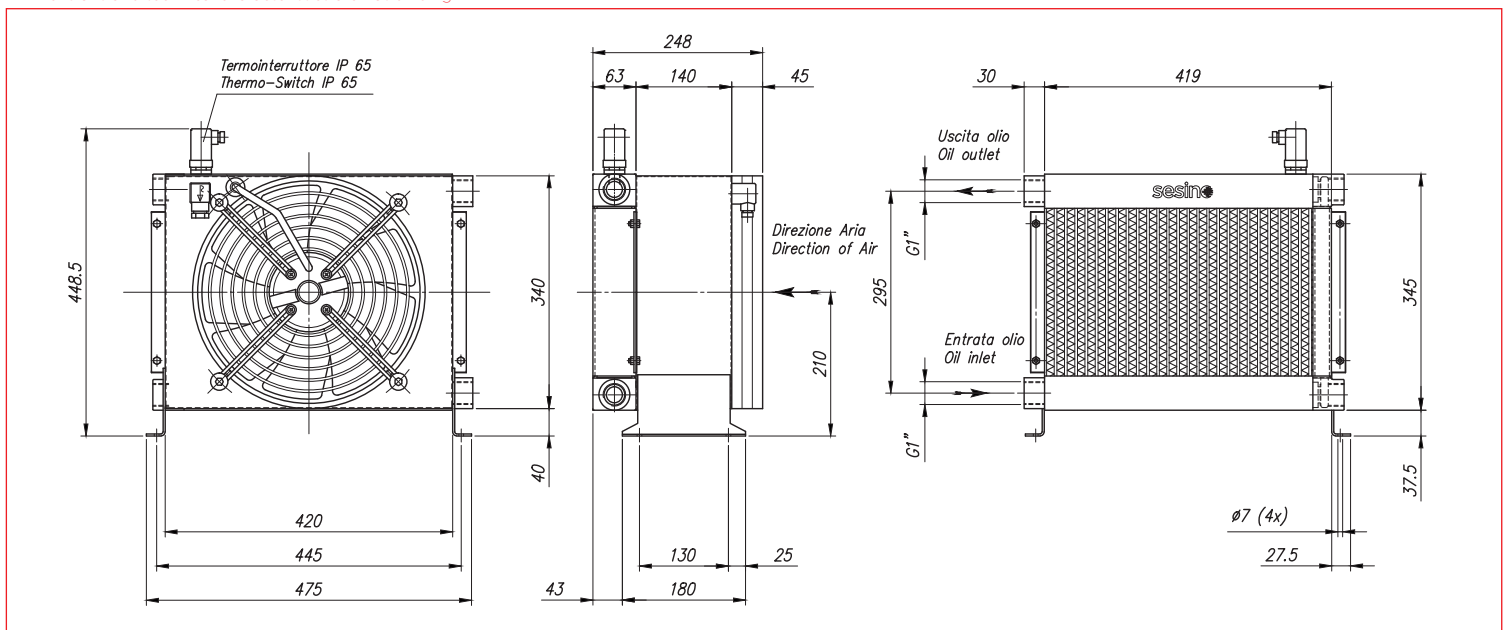

OIL FLOW	VOLTAGE	FREQUENCY	POWER	CURRENT	AIR FLOW	PROTECTION	NOISE LEVEL	WEIGHT	Ø FAN
l/min	V	hz	W	A	m³/h	IP	dB(A)	kg	mm
30-180	230	50/60	115/150	0,51/0,66	1.300	54	75	17	250
30-180	400	50/60	100/140	0,20/0,23	1.300	54	73	17	250

BC 390 AC



PURCHASE CODES

BC 390 single phase without thermo switch	3RBC390
BC 390 single phase with thermo switch	3RBC390T247 3RBC390T260
BC 390 three phase without thermo switch	3RBC39038
BC 390 three phase with thermo switch	3RBC39038T247 3RBC39038T260

SPARE PARTS

Cooling element	1RO03381
Frame	3CNBC390M/T.1
Electric fan for BC 250 single phase	1VNA4E350
Electric fan for BC 250 three phase	1VNELCO43038DV1
Thermo-switch 47-36 IP 65	1TRM 47-36
Thermo-switch 60-49 IP 65	1TRM 60-49

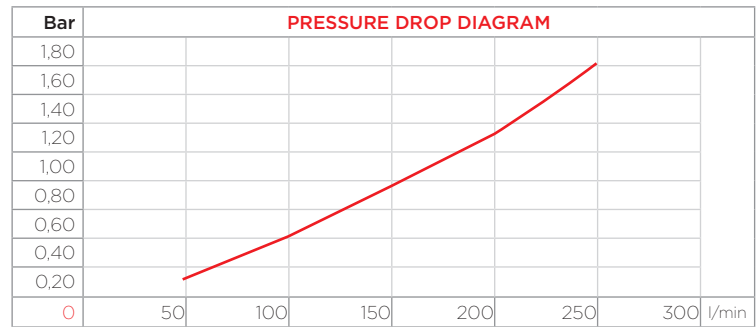
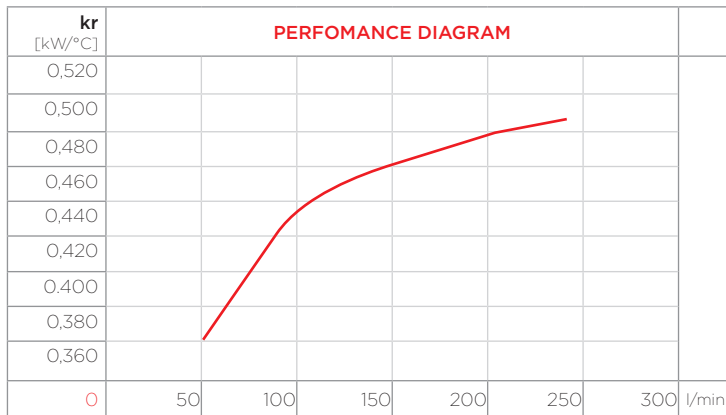

CORRECTION FACTOR

cSt	22	30	46	68	100	150	220
f	0.6	1	1.5	2.3	3.5	5	7

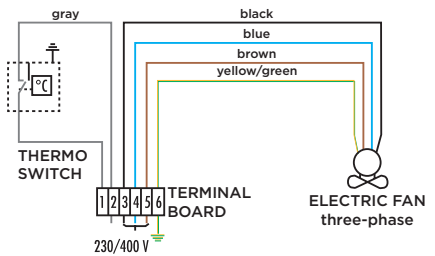

- Dimensions and technical characteristics are not binding

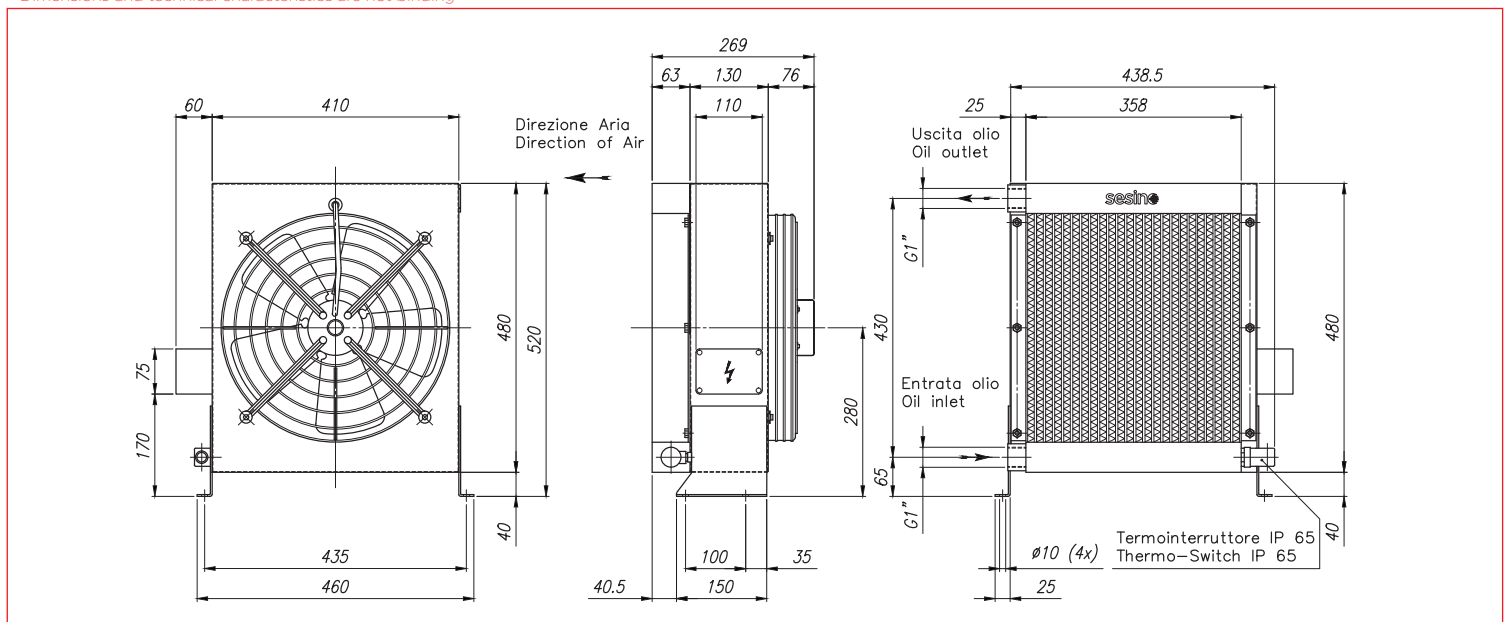

OIL FLOW	VOLTAGE	FREQUENCY	POWER	CURRENT	AIR FLOW	PROTECTION	NOISE LEVEL	WEIGHT	Ø FAN
l/min	V	hz	W	A	m ³ /h	IP	dB(A)	kg	mm
50-250	Δ 230 Y 400	50	100/170	0.62/0.30	2.750	55	73	22	350
50-250	Δ 265 Y 460	60	100/180	0.50/0.29	2.750	55	73	22	350

BC 390 AC BY-PASS



PURCHASE CODES

BC 390 single phase without thermo switch	3RBC390BP
BC 390 single phase with thermo switch	3RBC390T247BP 3RBC390T260BP
BC 390 three phase without thermo switch	3RBC39038BP
BC 390 three phase with thermo switch	3RBC39038T247BP 3RBC39038T260BP

SPARE PARTS

Cooling element	1RO03381BP
Frame	3CNBC390M/T1
Electric fan for BC 390 single phase	1VNA4E350
Electric fan for BC 390 three phase	1VNELCO43038DV1
Thermo-switch 47-36 IP 65	1TRM 47-36
Thermo-switch 60-49 IP 65	1TRM 60-49
By-pass	9FTBC

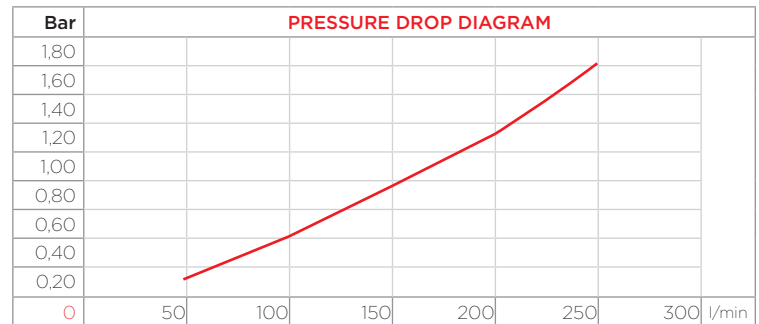
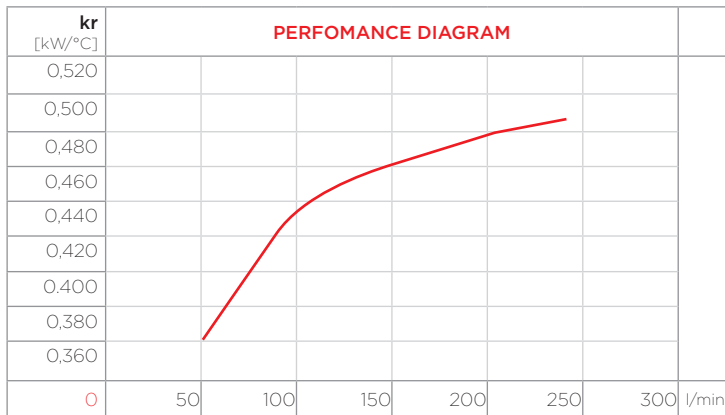

CORRECTION FACTOR

cSt	22	30	46	68	100	150	220
f	0.6	1	1.5	2.3	3.5	5	7

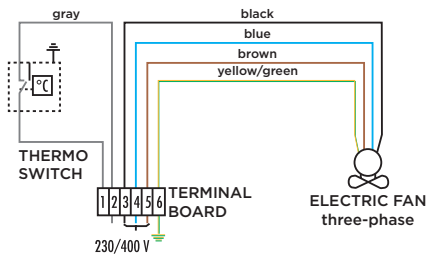

- Dimensions and technical characteristics are not binding

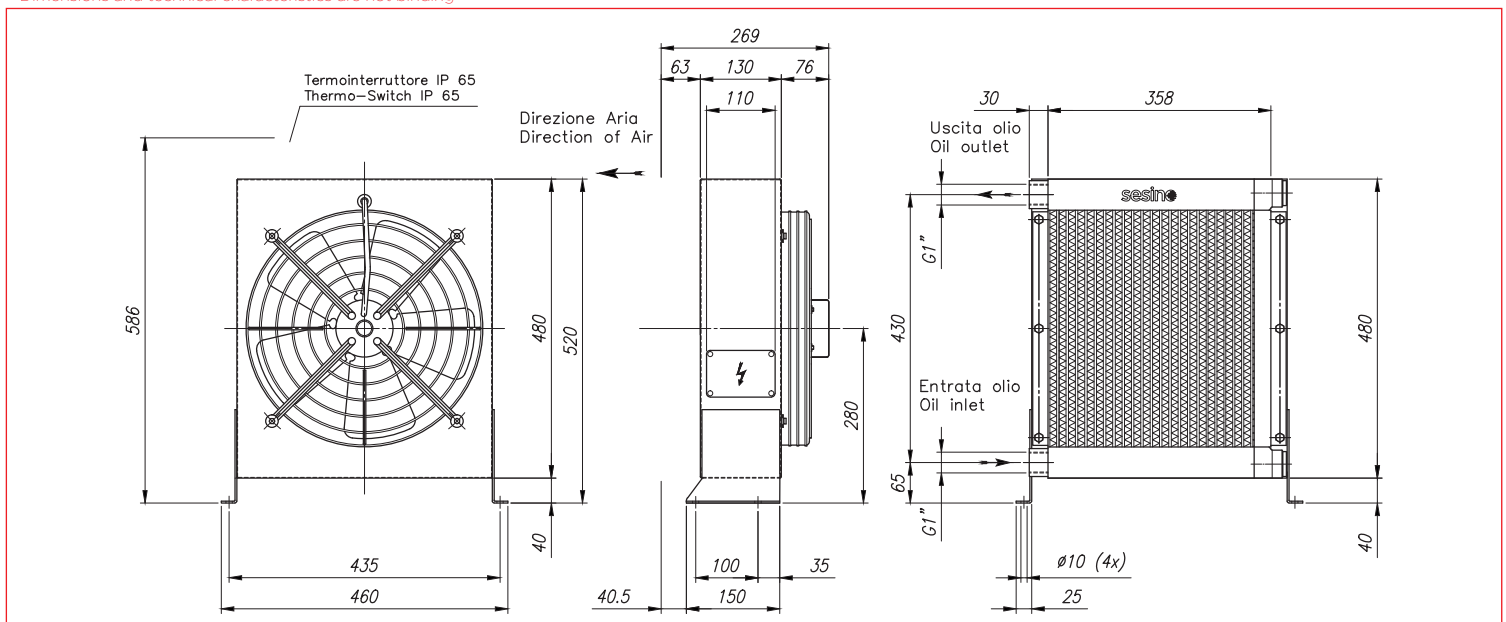

OIL FLOW	VOLTAGE	FREQUENCY	POWER	CURRENT	AIR FLOW	PROTECTION	NOISE LEVEL	WEIGHT	Ø FAN
l/min	V	hz	W	A	m ³ /h	IP	dB(A)	kg	mm
50-250	Δ 230 Y 400	50	100/170	0,62/0,30	2.750	55	73	22	350
50-250	Δ 265 Y 460	60	100/180	0,50/0,29	2.750	55	73	22	350

BC 390/2 AC



PURCHASE CODES

BC 390/2 single phase without thermo switch	3RBC390/2
BC 390/2 single phase with thermo switch	3RBC390/2T247 3RBC390/2T260
BC 390/2 three phase without thermo switch	3RBC390/238
BC 390/2 three phase with thermo switch	3RBC390/238T247 3RBC390/238T260

SPARE PARTS

Cooling element	1RO03383
Frame	3CNBC390/2M/T.1
Electric fan for BC 250 single phase	1VNEASS400
Electric fan for BC 250 three phase	1VNELCO43238DV2
Thermo-switch 47-36 IP 65	1TRM 47-36
Thermo-switch 60-49 IP 65	1TRM 60-49

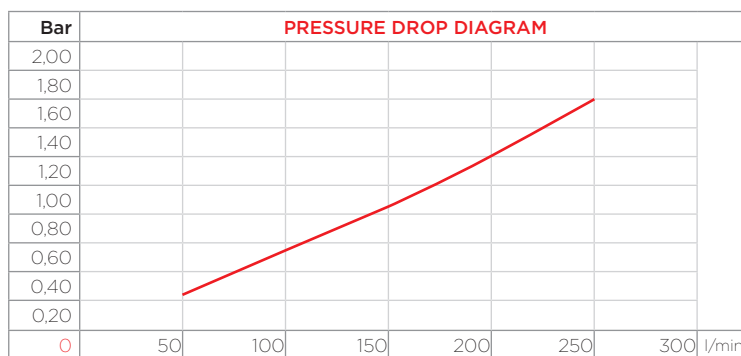
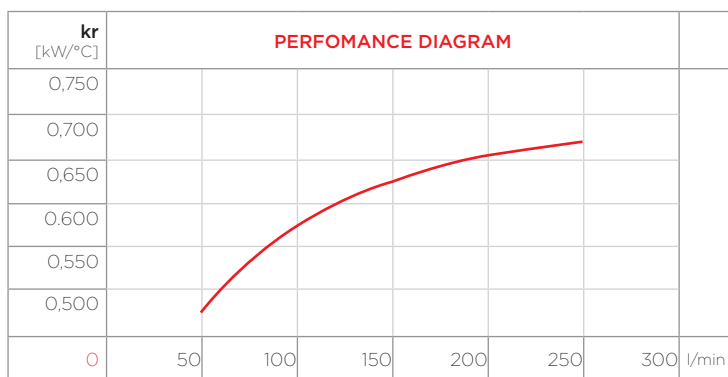

CORRECTION FACTOR

cSt	22	30	46	68	100	150	220
f	0.6	1	1.5	2.3	3.5	5	7

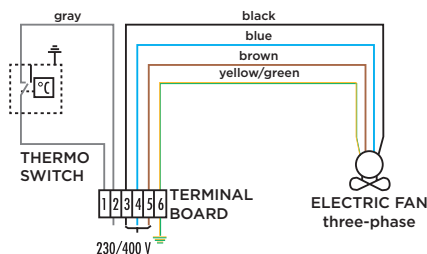

- Dimensions and technical characteristics are not binding

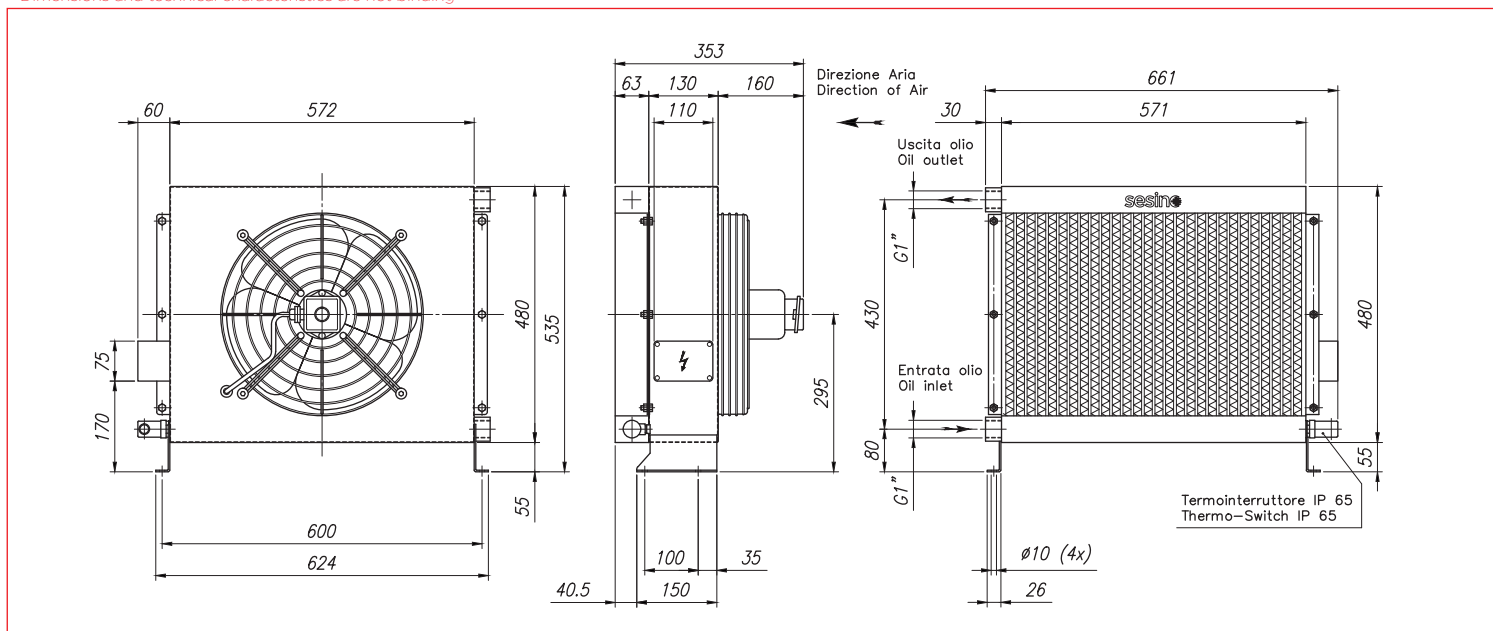

OIL FLOW	VOLTAGE	FREQUENCY	POWER	CURRENT	AIR FLOW	PROTECTION	NOISE LEVEL	WEIGHT	Ø FAN
l/min	V	hz	W	A	m ³ /h	IP	dB(A)	kg	mm
50-250	Δ 230 Y 400	50	110/180	0.57/0.33	2.750	55	72	31	400
50-250	Δ 265 Y 460	60	145/260	0.68/0.39	3.300	55	73	31	400

BC 390/2 AC BY-PASS



PURCHASE CODES

BC 390/2 single phase without thermo switch	3RBC390/2BP
BC 390/2 single phase with thermo switch	3RBC390/2T247BP 3RBC390/2T260BP
BC 390/2 three phase without thermo switch	3RBC390/238BP
BC 390/2 three phase with thermo switch	3RBC390/238T247BP 3RBC390/238T260BP

SPARE PARTS

Cooling element	1RO03383BP
Frame	3CNBC390/2M/T1
Electric fan for BC 390/2 single phase	1VNEASS400
Electric fan for BC 390/2 three phase	1VNELCO43238DV2
Thermo-switch 47-36 IP 65	1TRM 47-36
Thermo-switch 60-49 IP 65	1TRM 60-49
By-pass	9FTBC

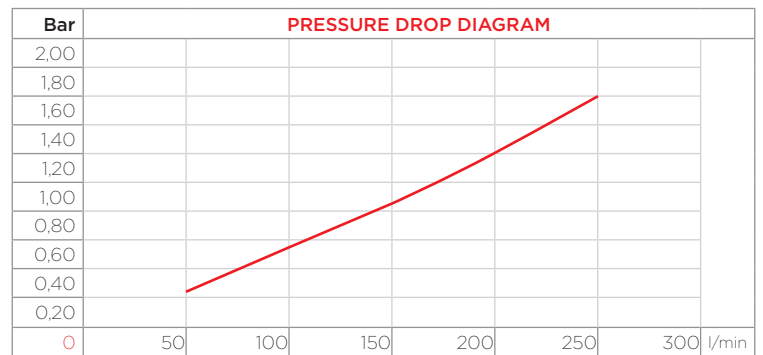
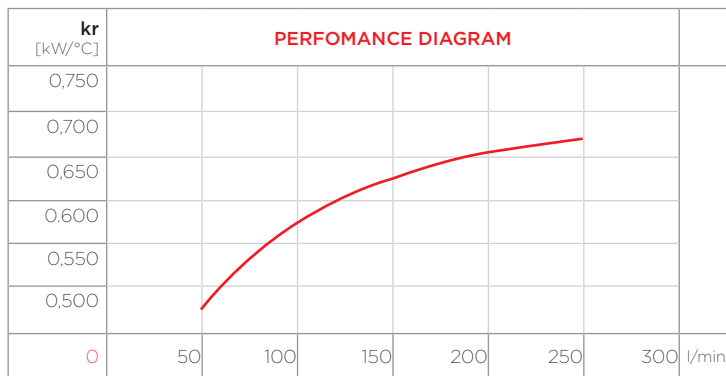

CORRECTION FACTOR

cSt	22	30	46	68	100	150	220
f	0,6	1	1,5	2,3	3,5	5	7

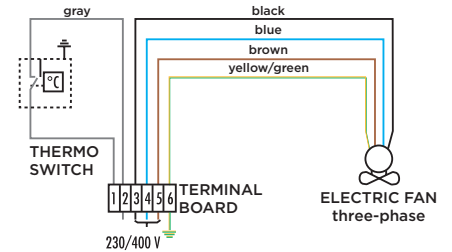

- Dimensions and technical characteristics are not binding

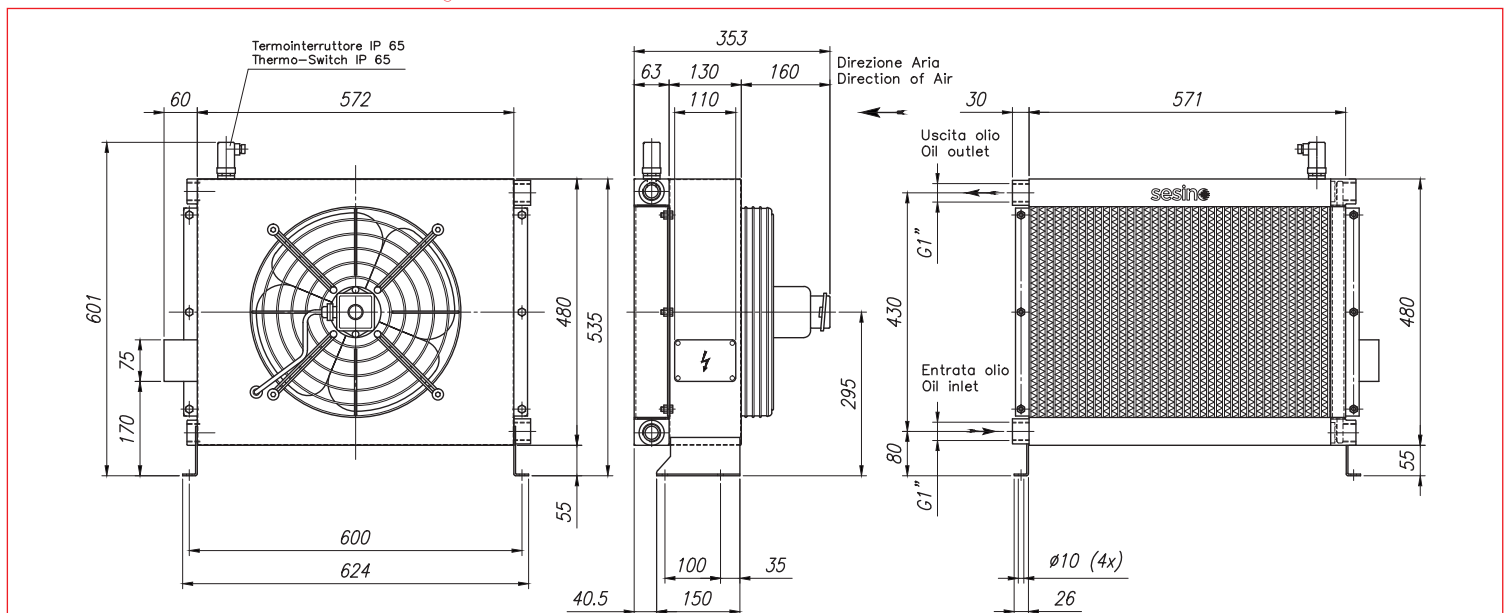

OIL FLOW	VOLTAGE	FREQUENCY	POWER	CURRENT	AIR FLOW	PROTECTION	NOISE LEVEL	WEIGHT	Ø FAN
l/min	V	hz	W	A	m ³ /h	IP	dB(A)	kg	mm
50-250	Δ 230 Y 400	50	110/180	0,57/0,33	2.750	55	72	31	400
50-250	Δ 265 Y 460	60	145/260	0,68/0,39	3.300	55	73	31	400

BC 390/3 AC BY-PASS



PURCHASE CODES

BC 390/3 single phase without thermo switch	3RBC390/3BP
BC 390/3 single phase with thermo switch	3RBC390/3T247BP 3RBC390/3T260BP
BC 390/3 three phase without thermo switch	3RBC390/338BP
BC 390/3 three phase with thermo switch	3RBC390/338T247BP 3RBC390/338T260BP

SPARE PARTS

Cooling element	1RO14494BP
Frame	3CNBC390/3M/T1
Electric fan for BC 390/2 single phase	1VNEASS400
Electric fan for BC 390/2 three phase	1VNELCO43238DV2
Thermo-switch 47-36 IP 65	1TRM 47-36
Thermo-switch 60-49 IP 65	1TRM 60-49
By-pass	9FTBC

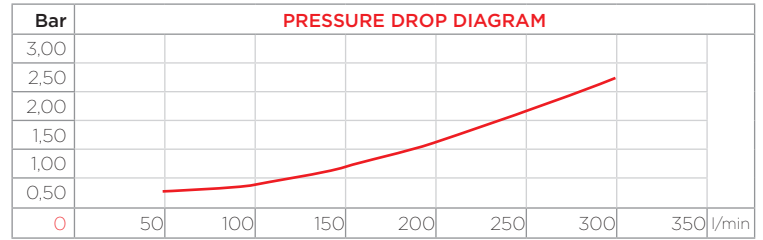
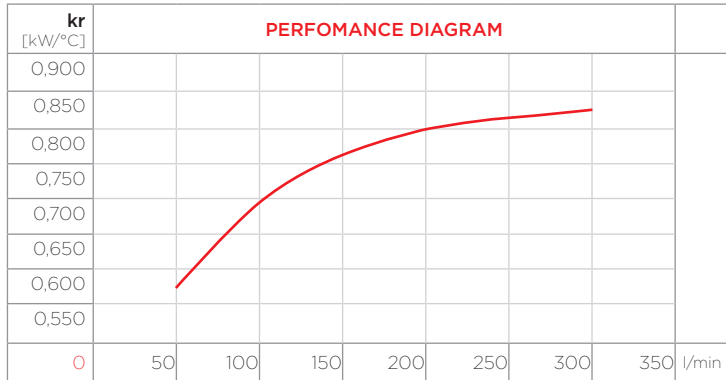

CORRECTION FACTOR

cSt	22	30	46	68	100	150	220
f	0,6	1	1,5	2,3	3,5	5	7

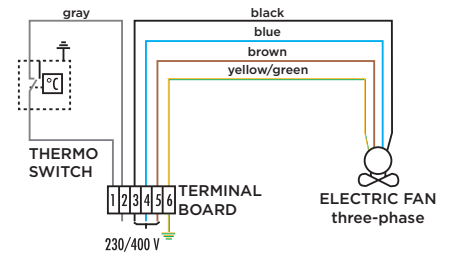

- Dimensions and technical characteristics are not binding

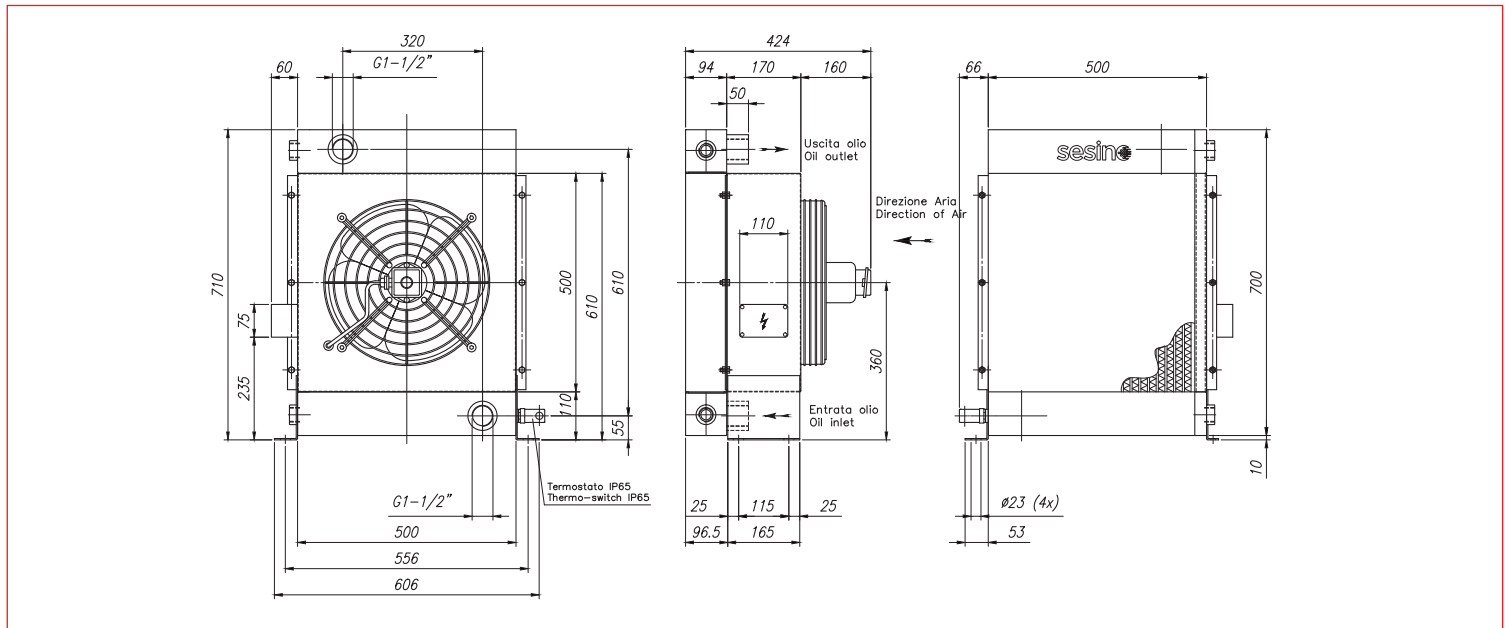

OIL FLOW	VOLTAGE	FREQUENCY	POWER	CURRENT	AIR FLOW	PROTECTION	NOISE LEVEL	WEIGHT	ø FAN
l/min	V	hz	W	A	m ³ /h	IP	dB(A)	kg	mm
50-300	Δ 230 Y 400	50	110/180	0.57/0.33	3.500	55	72	40	400
50-300	Δ 265 Y 460	60	145/260	0.68/0.39	4.800	55	72	40	400

BC 250 I



PURCHASE CODES

BC 250 I prepared	3RBC250I4A
BC 250 I with hydraulic motor	3RBC250I1A

SPARE PARTS

Cooling element	1RO03378
Frame	3CNAP300I1
Hydraulic motor	1MO2/M16
Fan	1G2806230PAV
Fan grill	1RTAP300I
Thermo-switch 47-36 IP 65	1TRM 47-36
Thermo-switch 60-49 IP 65	1TRM 60-49

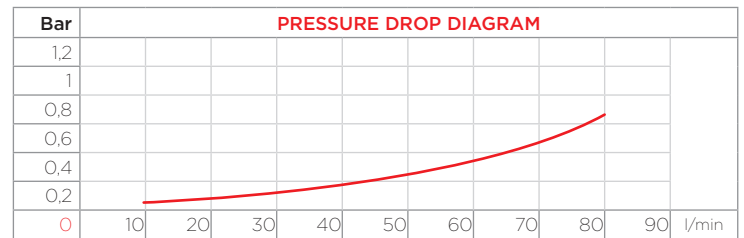
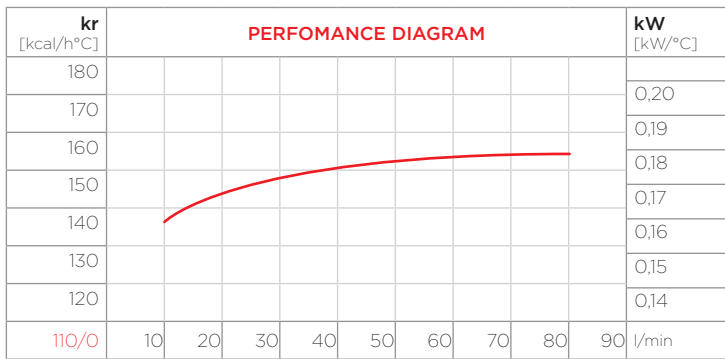

CORRECTION FACTOR

cSt	22	30	46	68	100	150	220
f	0,6	1	1,5	2,3	3,5	5	7

- Dimensions and technical characteristics are not binding

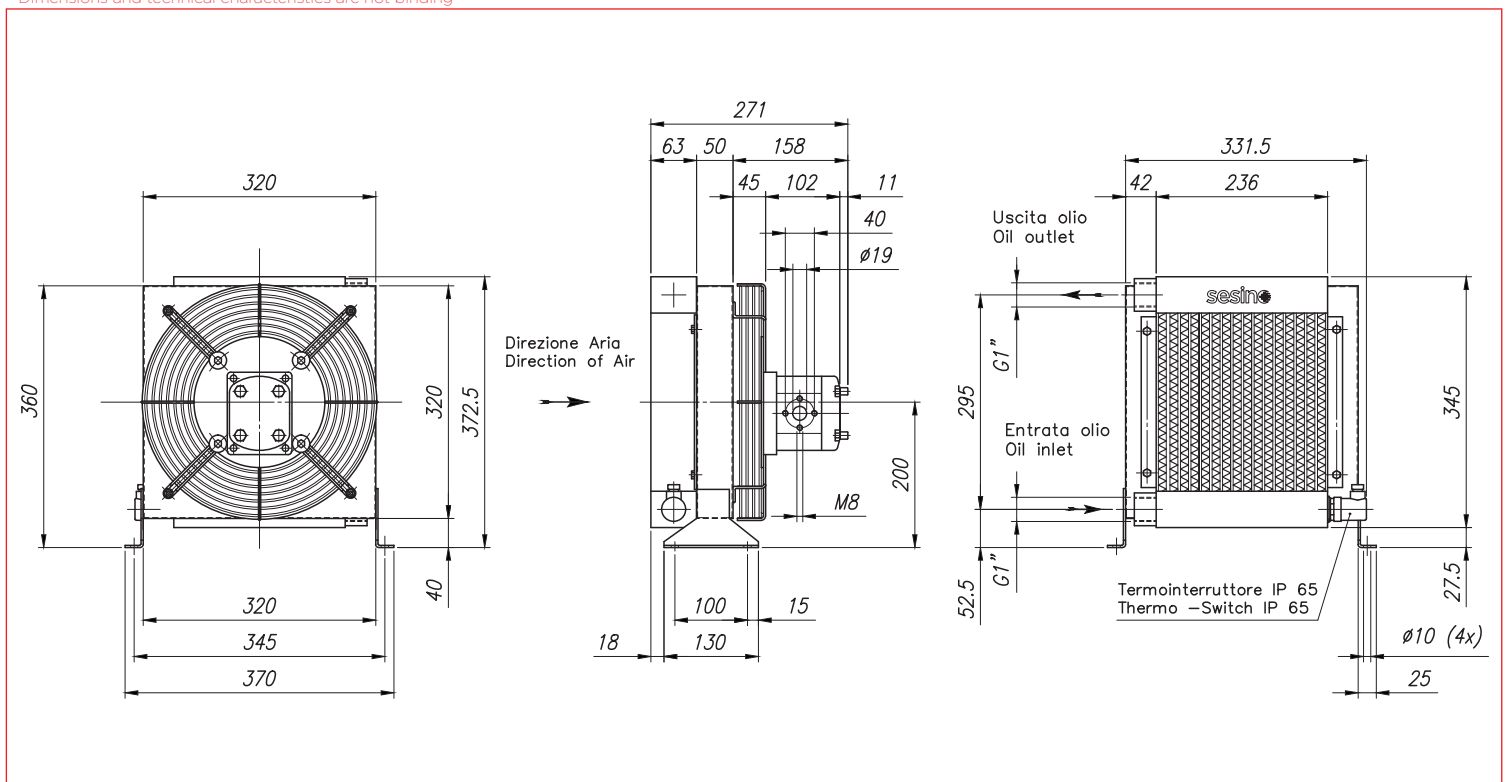

OIL FLOW	FAN SPEED	POWER	DISPLACEMENT	MOTOR FLOW	AIR FLOW	NOISE LEVEL	WEIGHT	ø FAN
l/min	rpm	W	cc/r	l/min	m ³ /h	dB(A)	kg	mm
20-150	2300	200	11,3	26	2.000	68	14	255

BC 250 I BY-PASS



PURCHASE CODES

BC 250 I prepared	3RBC250I4ABP
BC 250 I with hydraulic motor	3RBC250I1ABP

SPARE PARTS

Cooling element	1RO03378BP
Frame	3CNAP300I.1
Hydraulic motor	1MO2/M16
Fan	1G2806230PAV
Fan grill	1RTAP300I
Thermo-switch 47-36 IP 65	1TRM 47-36
Thermo-switch 60-49 IP 65	1TRM 60-49
By-pass	9FTBC

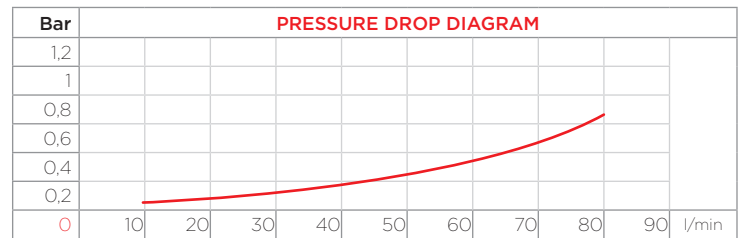
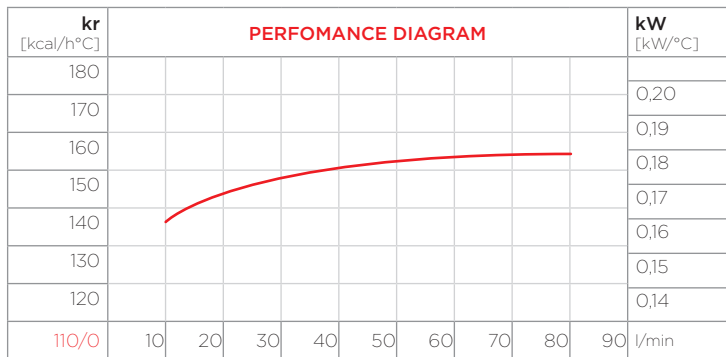

CORRECTION FACTOR

cSt	22	30	46	68	100	150	220
f	0,6	1	1,5	2,3	3,5	5	7

- Dimensions and technical characteristics are not binding

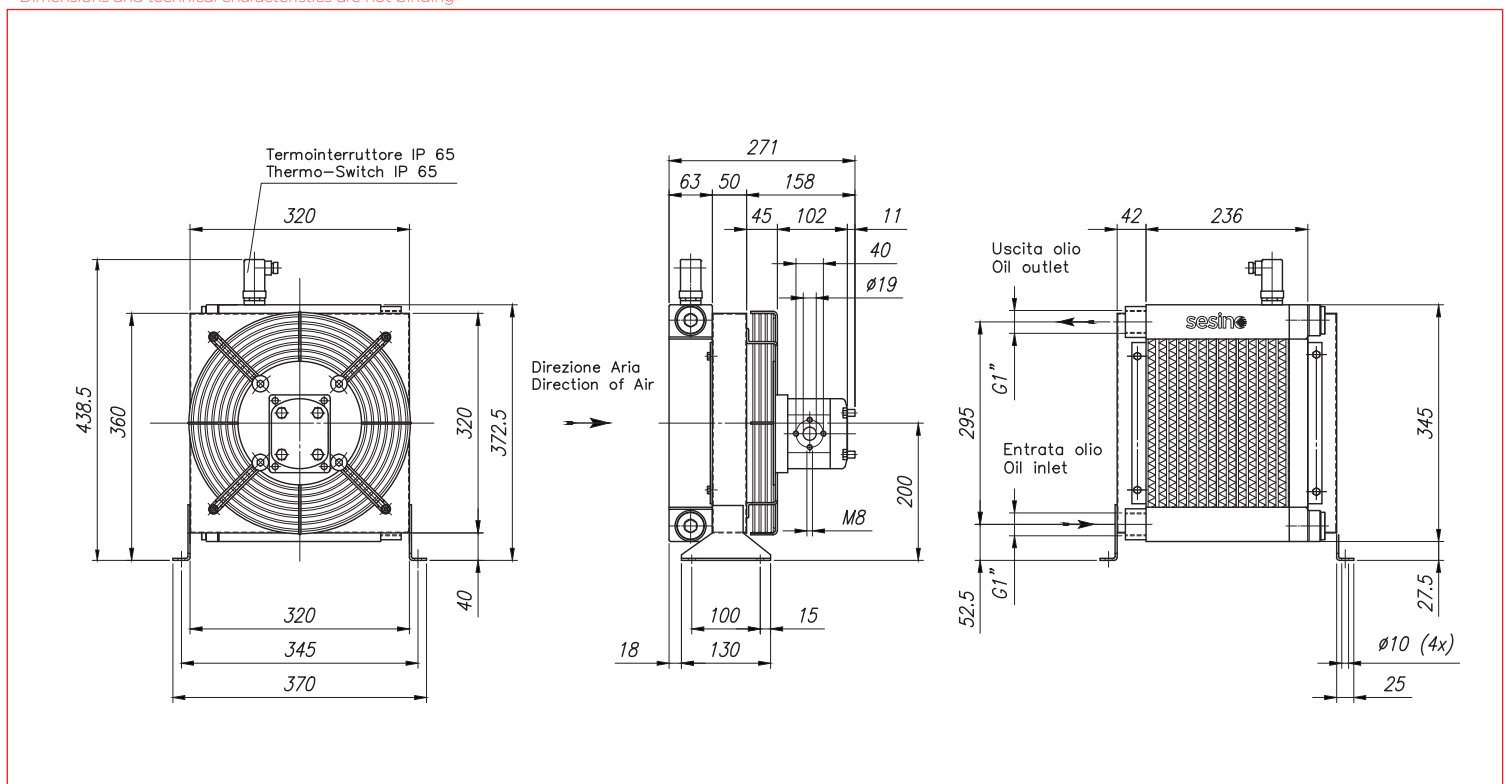

OIL FLOW	FAN SPEED	POWER	DISPLACEMENT	MOTOR FLOW	AIR FLOW	NOISE LEVEL	WEIGHT	ø FAN
l/min	rpm	W	cc/r	l/min	m ³ /h	dB(A)	kg	mm
20-150	2300	200	11,3	26	2.000	68	14	255

BC 250/2 I



PURCHASE CODES

BC 250/2 I prepared	3RBC250/2I4A
BC 250/2 I with hydraulic motor	3RBC250/2IIA

SPARE PARTS

Cooling element	1RO03378
Frame	3CNAP302I1
Hydraulic motor	1MO2/M16
Fan	1G2806230PAV
Fan grill	1RTAP300I
Thermo-switch 47-36 IP 65	1TRM 47-36
Thermo-switch 60-49 IP 65	1TRM 60-49

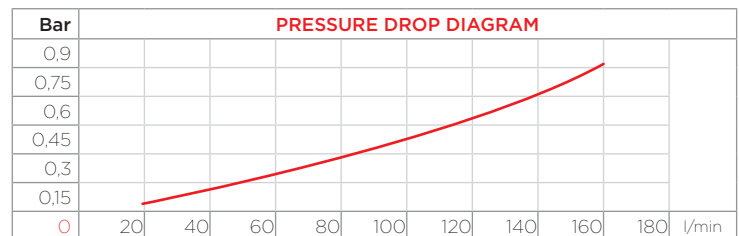
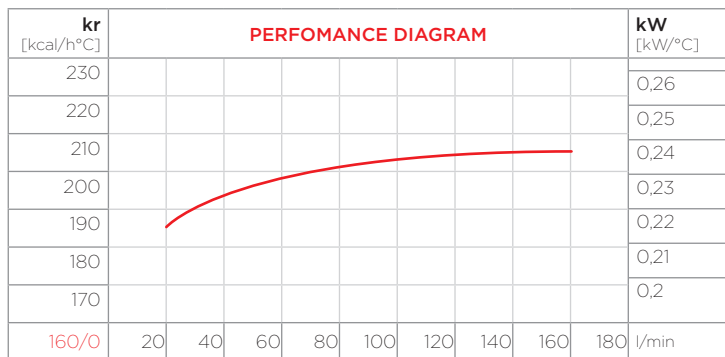

CORRECTION FACTOR

cSt	22	30	46	68	100	150	220
f	0,6	1	1,5	2,3	3,5	5	7

- Dimensions and technical characteristics are not binding

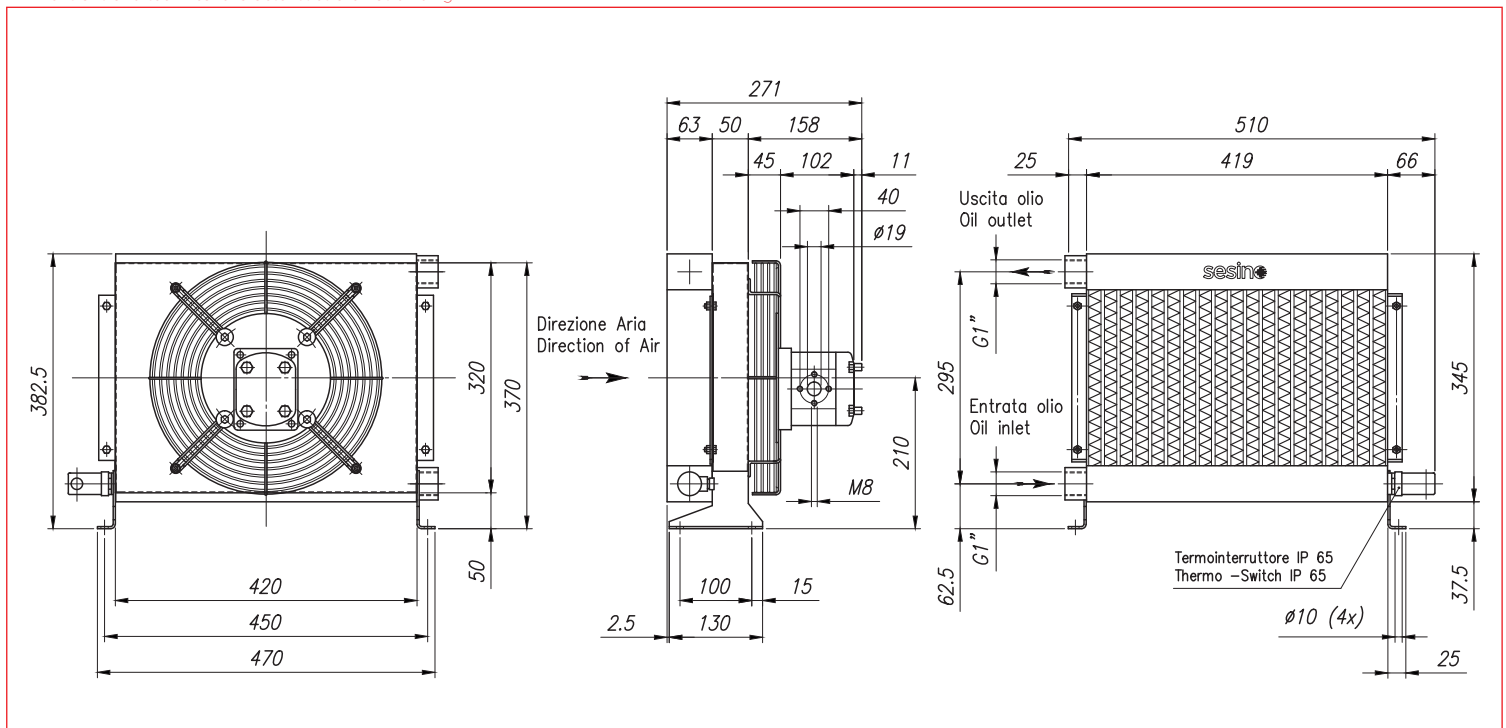

OIL FLOW	FAN SPEED	POWER	DISPLACEMENT	MOTOR FLOW	AIR FLOW	NOISE LEVEL	WEIGHT	ø FAN
l/min	rpm	W	cc/r	l/min	m ³ /h	dB(A)	kg	mm
30-180	2300	200	11,3	26	2.500	70	19	255

BC 250/2 I BY-PASS



PURCHASE CODES

BC 250/2 I prepared	3RBC250/2I4ABP
BC 250/2 I with hydraulic motor	3RBC250/2I1ABP

SPARE PARTS

Cooling element	1RO03378BP
Frame	3CNAP302I.1
Hydraulic motor	1MO2/M16
Fan	1G2806230PAV
Fan grill	1RTAP300I
Thermo-switch 47-36 IP 65	1TRM 47-36
Thermo-switch 60-49 IP 65	1TRM 60-49
By-pass	9FTBC

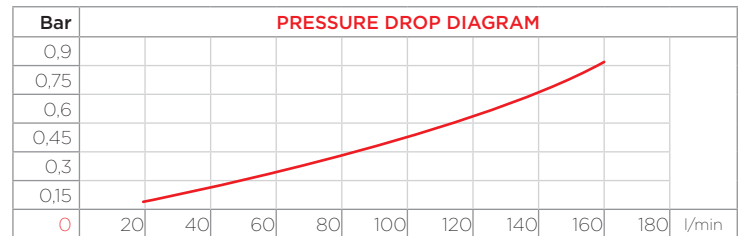
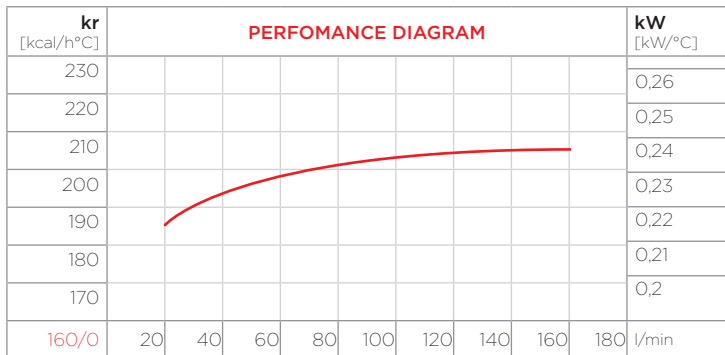

CORRECTION FACTOR

cSt	22	30	46	68	100	150	220
f	0,6	1	1,5	2,3	3,5	5	7

- Dimensions and technical characteristics are not binding

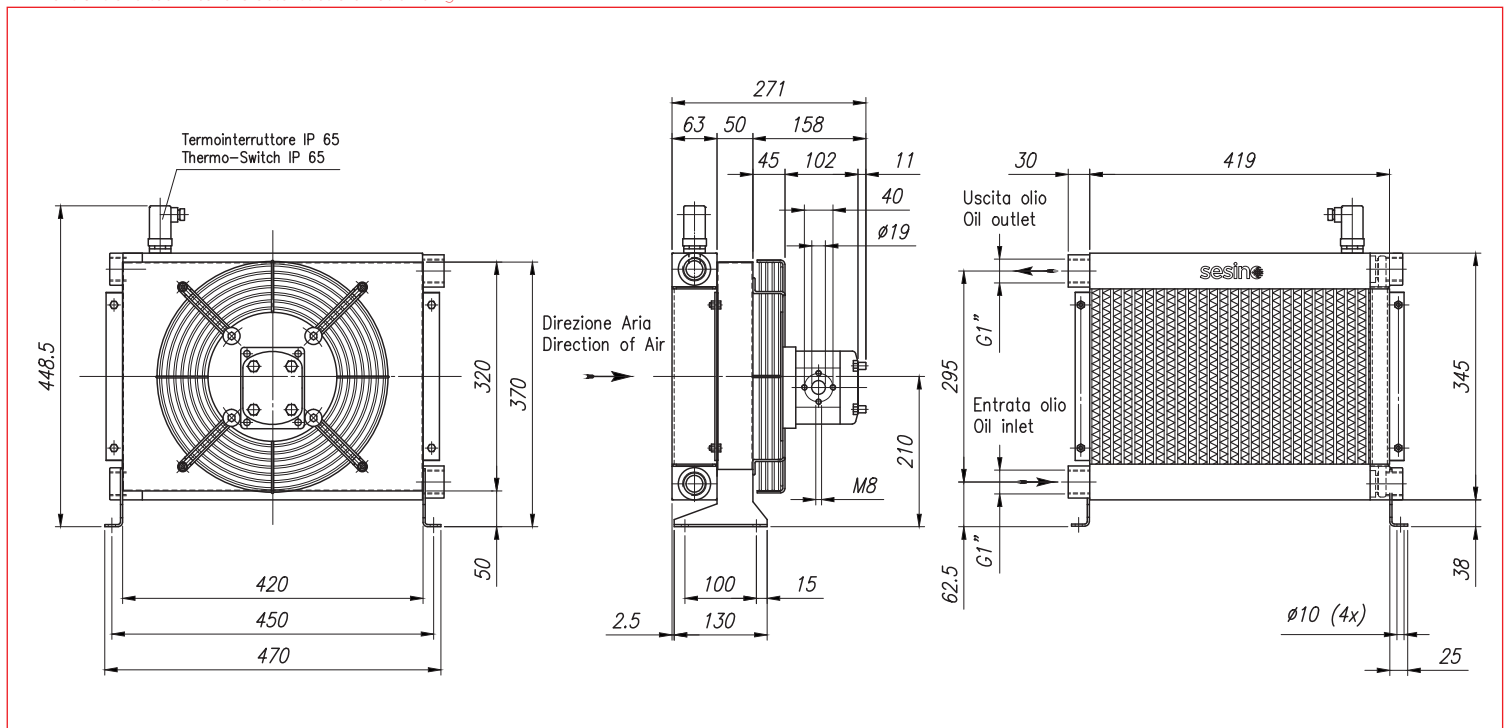

OIL FLOW	FAN SPEED	POWER	DISPLACEMENT	MOTOR FLOW	AIR FLOW	NOISE LEVEL	WEIGHT	Ø FAN
l/min	rpm	W	cc/r	l/min	m³/h	dB(A)	kg	mm
30-180	2300	200	11,3	26	2.500	70	19	255

BC 390 I



PURCHASE CODES

BC 390 I prepared	3RBC390I4A
BC 390 I with hydraulic motor	3RBC390I1A

SPARE PARTS

Cooling element	1RO03381
Frame	3CNBC390I.1
Hydraulic motor	1MO2/M16
Fan	1G3506345PAV
Fan grill	1RTAP430I
Thermo-switch 47-36 IP 65	1TRM 47-36
Thermo-switch 60-49 IP 65	1TRM 60-49

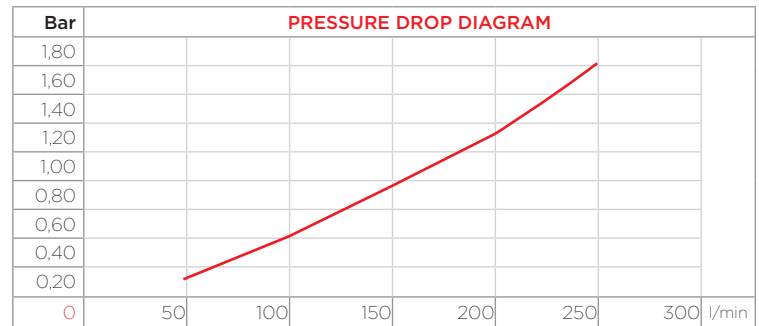
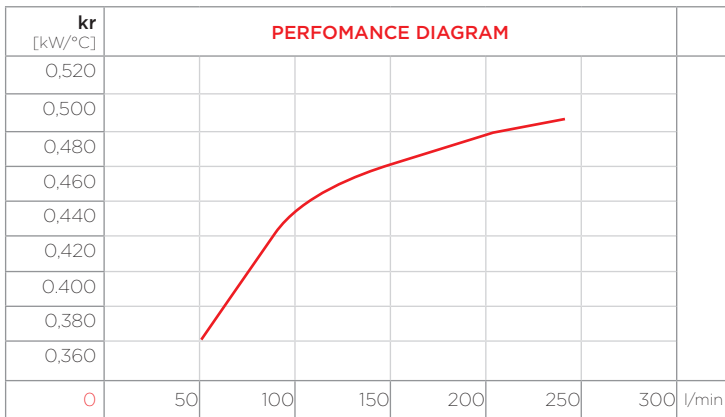

CORRECTION FACTOR

cSt	22	30	46	68	100	150	220
f	0,6	1	1,5	2,3	3,5	5	7

- Dimensions and technical characteristics are not binding

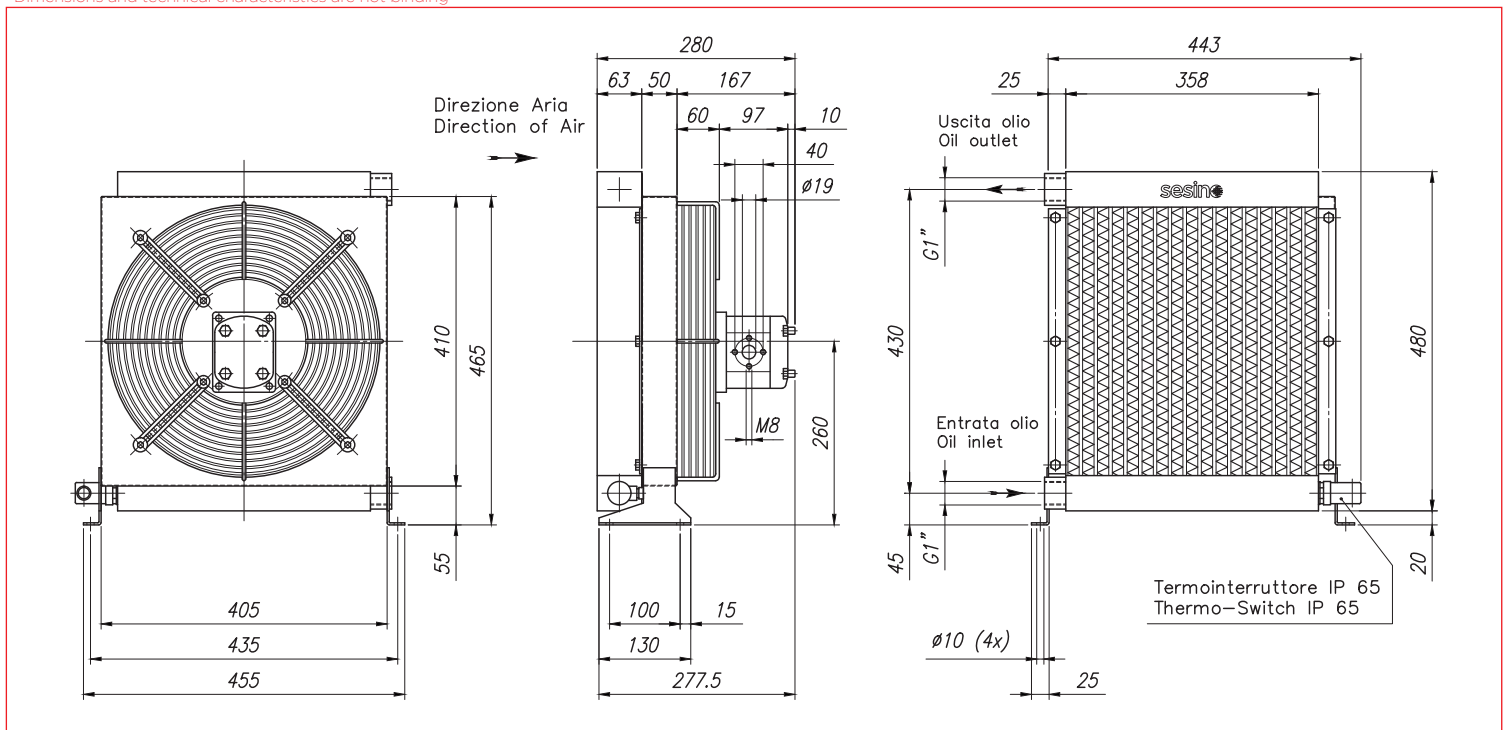

OIL FLOW	FAN SPEED	POWER	DISPLACEMENT	MOTOR FLOW	AIR FLOW	NOISE LEVEL	WEIGHT	ø FAN
l/min	rpm	W	cc/r	l/min	m ³ /h	dB(A)	kg	mm
50-250	2.700	770	11,3	31	7.000	73	21	355

BC 390 I BY-PASS



PURCHASE CODES

BC 390 I prepared	3RBC390I4ABP
BC 390 I with hydraulic motor	3RBC390I1ABP

SPARE PARTS

Cooling element	1RO03381BP
Frame	3CNBC390I.1
Hydraulic motor	1MO2/M16
Fan	1G3506345PAV
Fan grill	1RTAP430I
Thermo-switch 47-36 IP 65	1TRM 47-36
Thermo-switch 60-49 IP 65	1TRM 60-49
By-pass	9FTBC

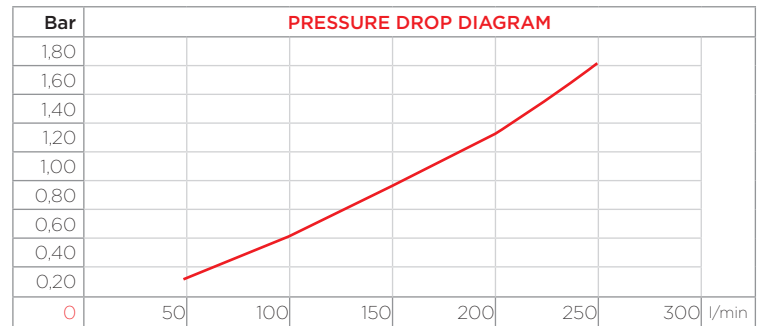
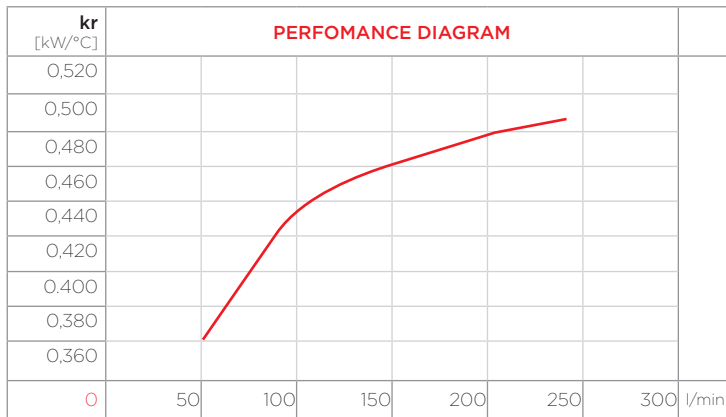

CORRECTION FACTOR

cSt	22	30	46	68	100	150	220
f	0,6	1	1,5	2,3	3,5	5	7

- Dimensions and technical characteristics are not binding

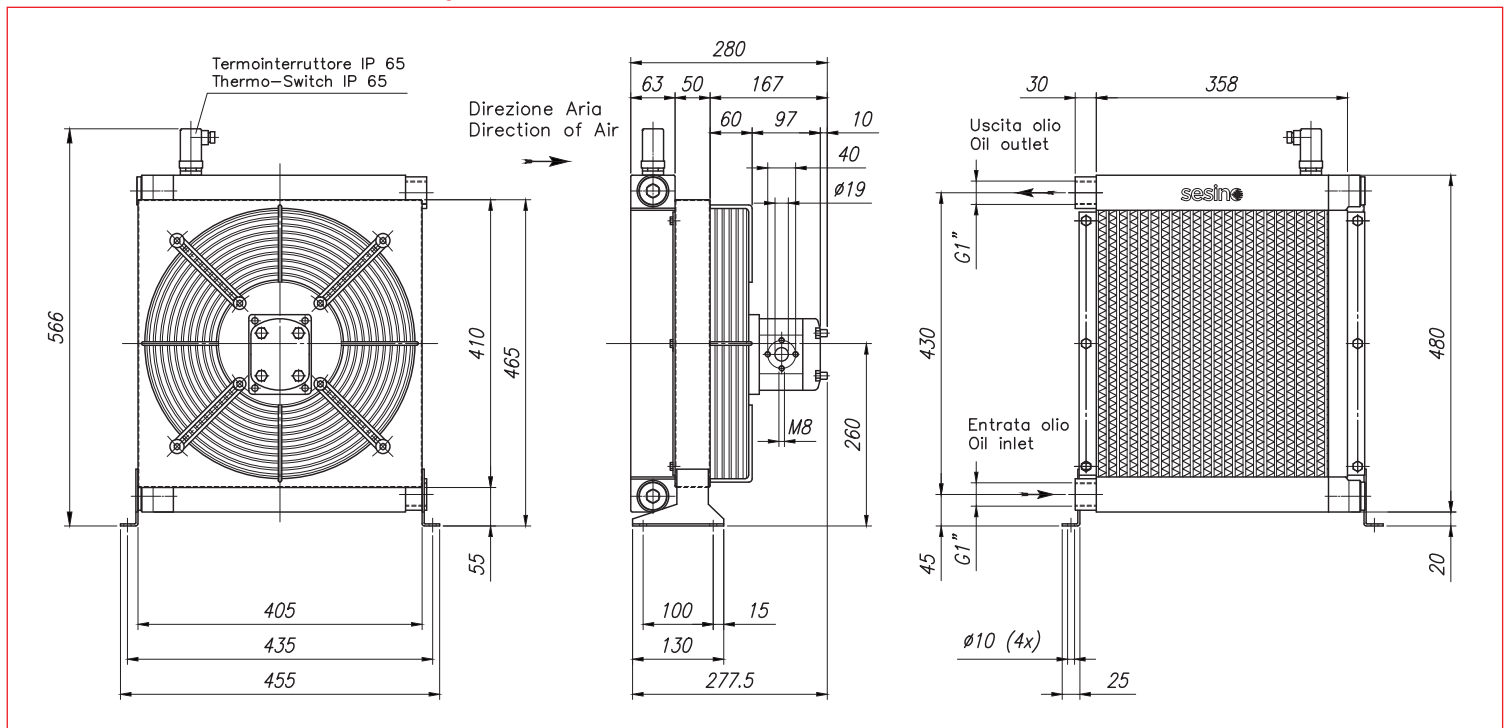

OIL FLOW	FAN SPEED	POWER	DISPLACEMENT	MOTOR FLOW	AIR FLOW	NOISE LEVEL	WEIGHT	Ø FAN
l/min	rpm	W	cc/r	l/min	m ³ /h	dB(A)	kg	mm
50-250	2.700	830	11,3	31	7000	74	23	400

BC 390/2 I



PURCHASE CODES

BC 390/2 I prepared	3RBC390/2I4A
BC 390/2 I with hydraulic motor	3RBC390/2IIA

SPARE PARTS

Cooling element	1RO03383
Frame	3CNBC390/2I1
Hydraulic motor	1MO2/M16
Fan	1G40010345PAV
Fan grill	1RTAP580I
Thermo-switch 47-36 IP 65	1TRM 47-36
Thermo-switch 60-49 IP 65	1TRM 60-49

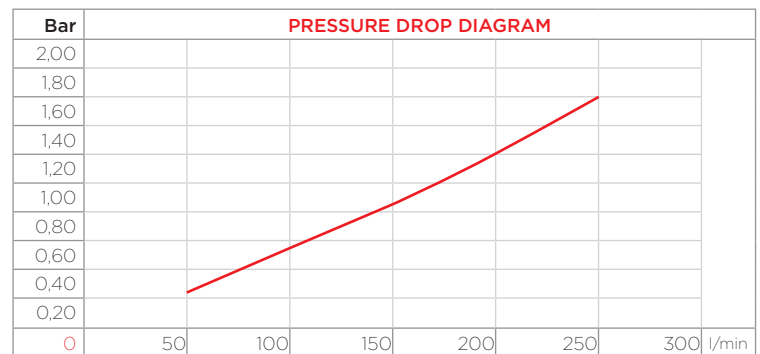
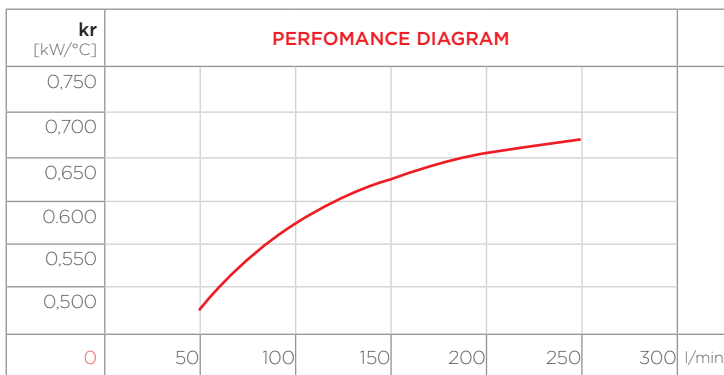

CORRECTION FACTOR

cSt	22	30	46	68	100	150	220
f	0,6	1	1,5	2,3	3,5	5	7

- Dimensions and technical characteristics are not binding

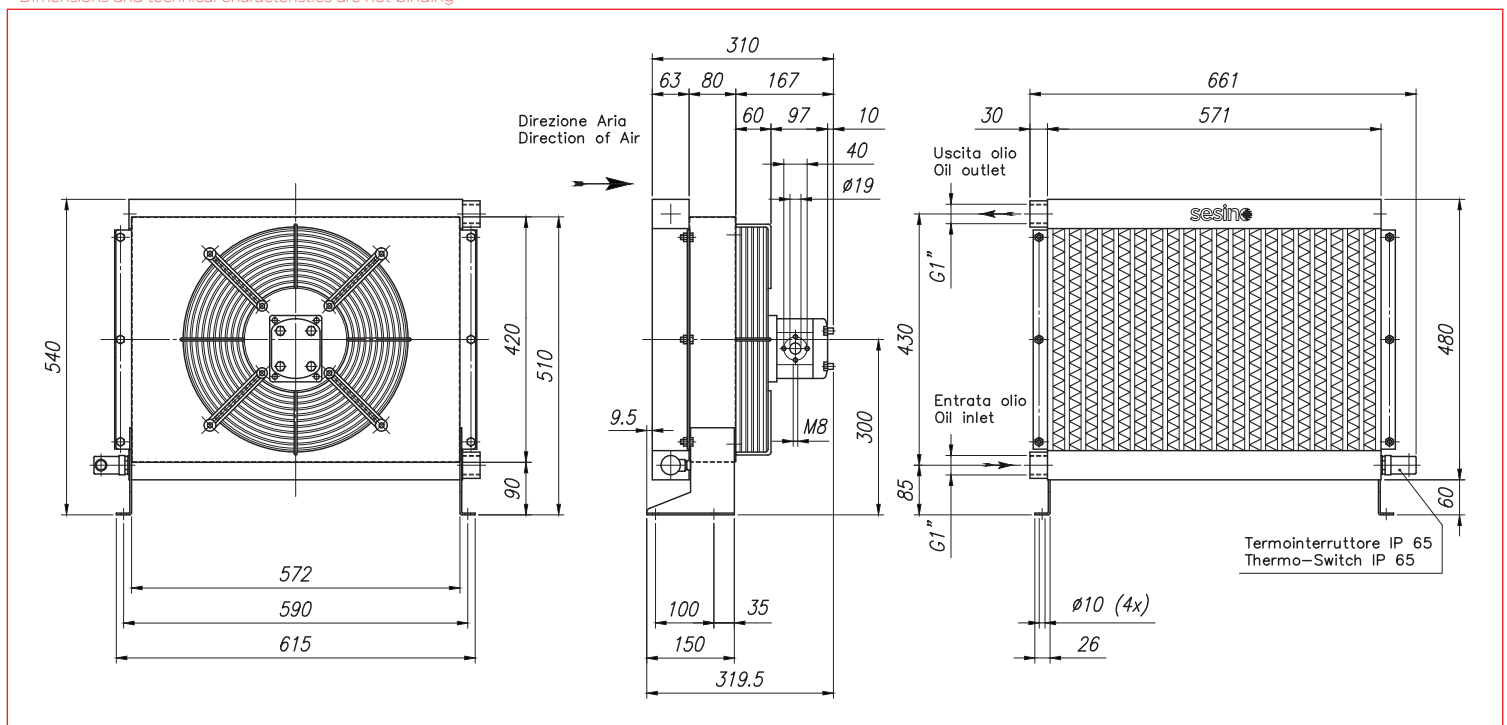

OIL FLOW	FAN SPEED	POWER	DISPLACEMENT	MOTOR FLOW	AIR FLOW	NOISE LEVEL	WEIGHT	ø FAN
l/min	rpm	W	cc/r	l/min	m ³ /h	dB(A)	kg	mm
50-250	2.700	770	11,3	31	7.000	73	29	355

BC 390/2 I BY-PASS

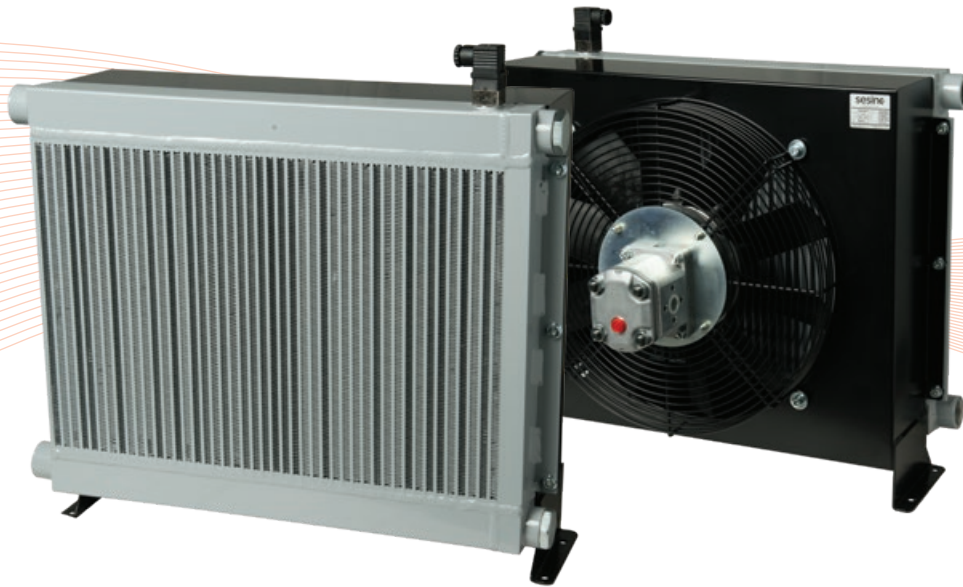

PURCHASE CODES

BC 390/2 I prepared	3RBC390/2I4ABP
BC 390/2 I with hydraulic motor	3RBC390/2I1ABP

SPARE PARTS

Cooling element	1R003383BP
Frame	3CNBC390/2I.1
Hydraulic motor	1MO2/M16
Fan	1G40010345PAV
Fan grill	1RTAP580I
Thermo-switch 47-36 IP 65	1TRM 47-36
Thermo-switch 60-49 IP 65	1TRM 60-49
By-pass	9FTBC

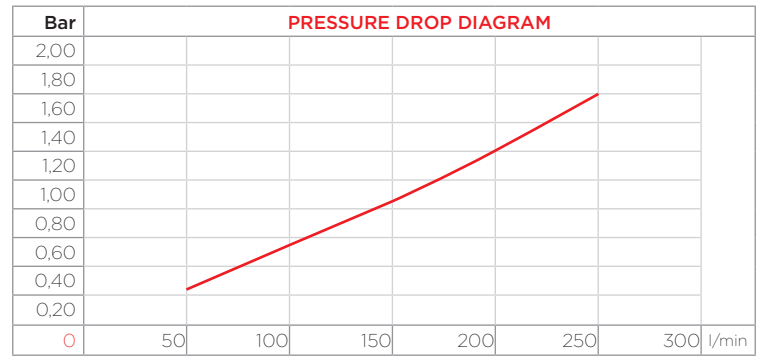
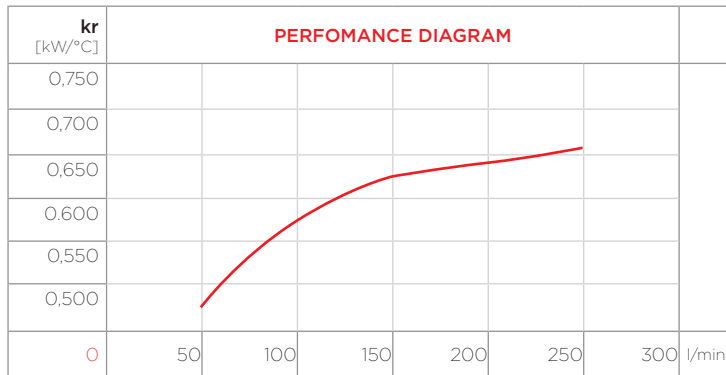

CORRECTION FACTOR

cSt	22	30	46	68	100	150	220
f	0,6	1	1,5	2,3	3,5	5	7

- Dimensions and technical characteristics are not binding

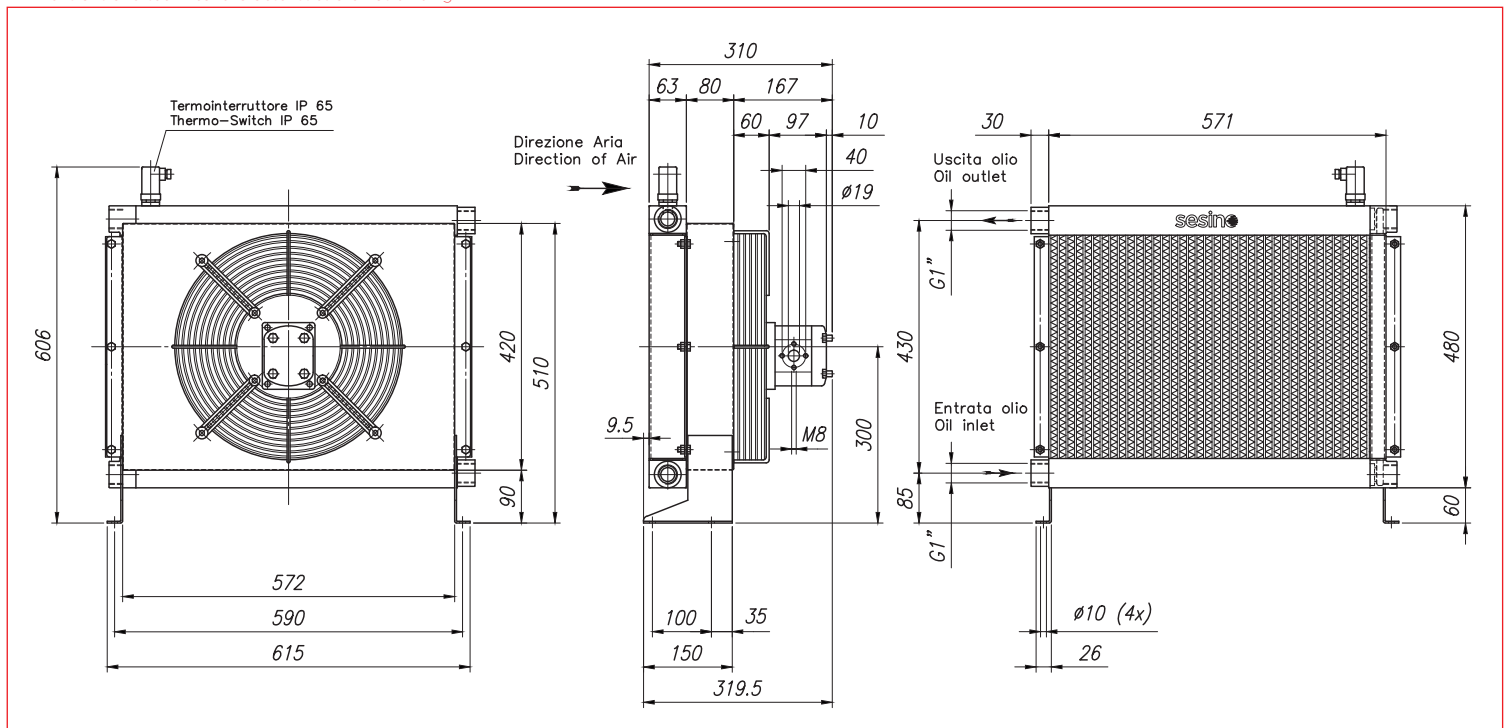

OIL FLOW	FAN SPEED	POWER	DISPLACEMENT	MOTOR FLOW	AIR FLOW	NOISE LEVEL	WEIGHT	ϕ FAN
l/min	rpm	W	cc/r	l/min	m ³ /h	dB(A)	kg	mm
50-250	2.700	830	11,3	31	7000	74	29	400

BC 390/3 I BY-PASS

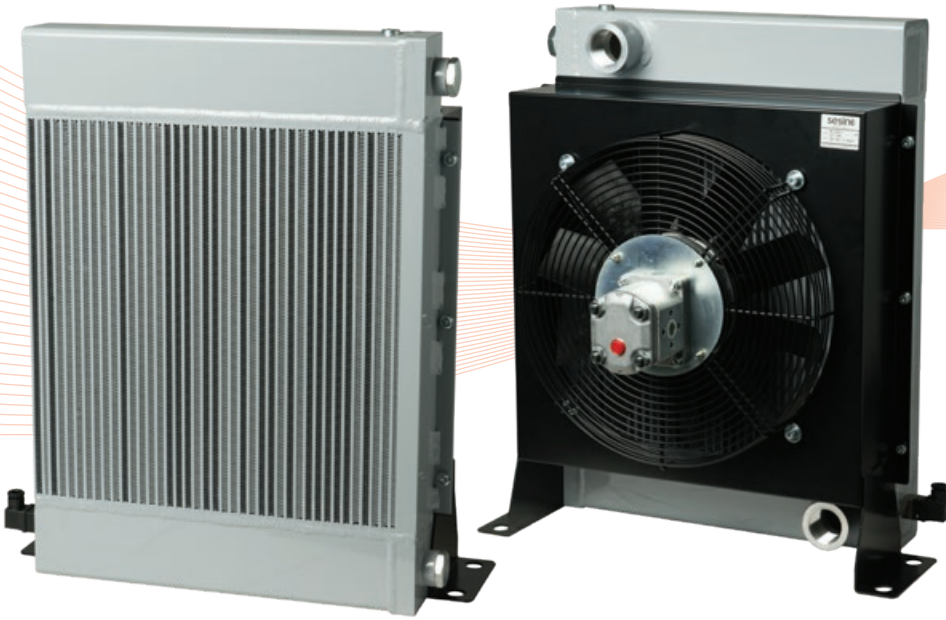

PURCHASE CODES

BC 390/3 I prepared	3RBC390/3I4ABP
BC 390/3 I with hydraulic motor	3RBC390/3I1ABP

SPARE PARTS

Cooling element	1RO14494BP
Frame	3CNBC390/3I.1
Hydraulic motor	1MO2/M16
Fan	1G40010345PAV
Fan grill	1RTAP580I
Thermo-switch 47-36 IP 65	1TRM 47-36
Thermo-switch 60-49 IP 65	1TRM 60-49
By-pass	9FTBC

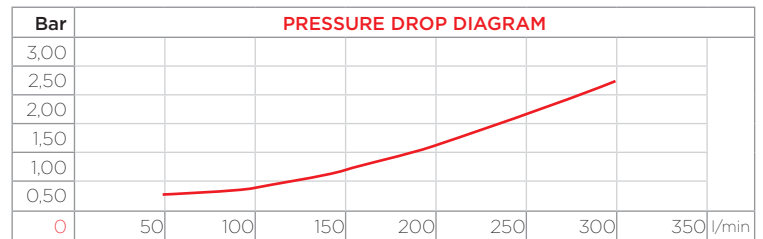
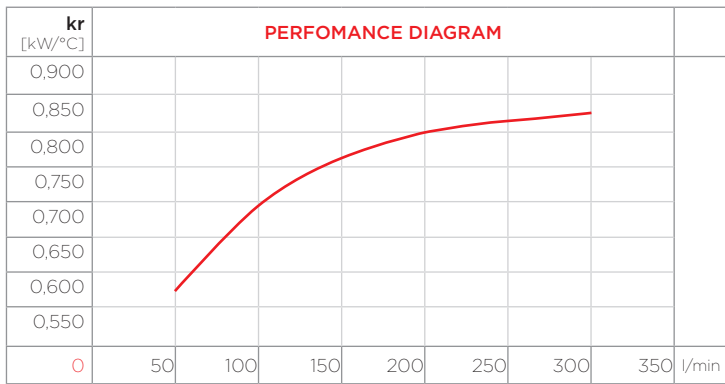

CORRECTION FACTOR

cSt	22	30	46	68	100	150	220
f	0,6	1	1,5	2,3	3,5	5	7

- Dimensions and technical characteristics are not binding

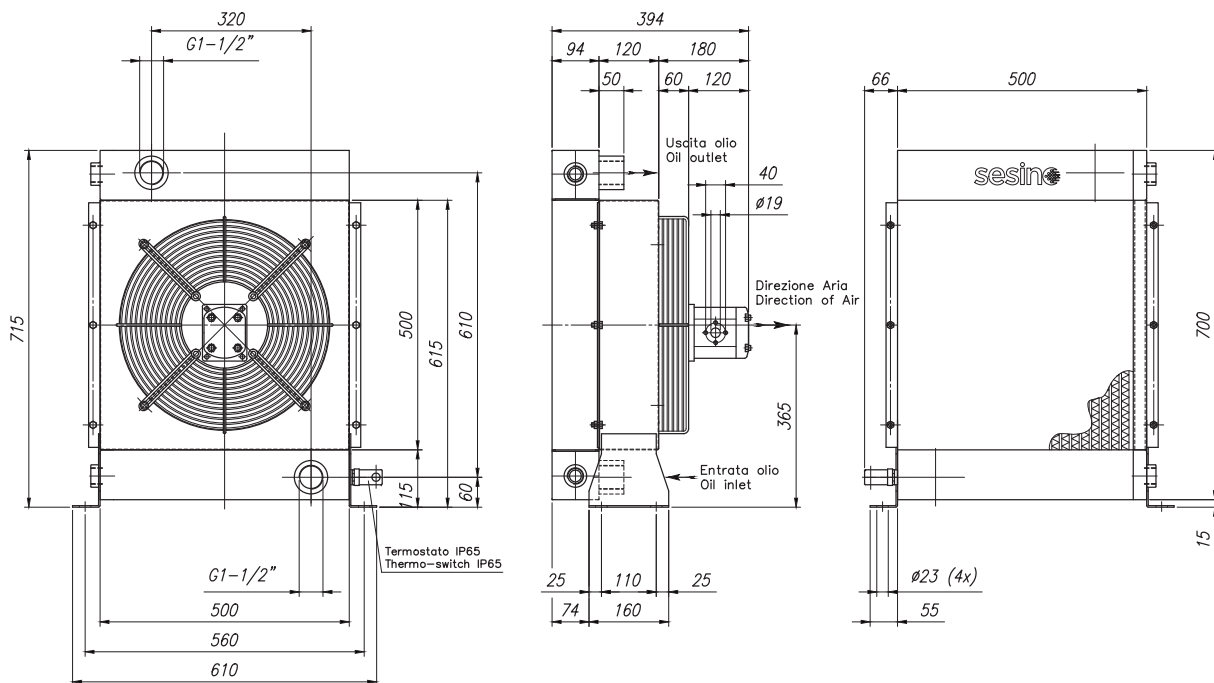

OIL FLOW	FAN SPEED	POWER	DISPLACEMENT	MOTOR FLOW	AIR FLOW	NOISE LEVEL	WEIGHT	Ø FAN
l/min	rpm	W	cc/r	l/min	m ³ /h	dB(A)	kg	mm
50-300	2250	880	11,3	26	8.000	78	38	400





Scan the following
QR Code to find us:



Sesino S.p.A. owns all the graphic elements of the present catalogue: the company's logo, the brand, the article's code, the drawings, and the graphic project of the catalogue. We reserve the right to act against any improper or unauthorized use. Our technical data, our descriptions and drawings are reproduced with the utmost care, we reserve nevertheless the right to make changes as appropriate.

La Sesino SpA detiene l'assoluta proprietà degli elementi grafici del presente catalogo, vale a dire: il logotipo aziendale, il marchio, il codice degli articoli, i disegni, il progetto grafico del catalogo, e si riserva la facoltà di difendere a termini di legge ogni illecito uso, non espressamente autorizzato. I nostri dati tecnici, le nostre descrizioni e i disegni sono riportati con la massima accuratezza possibile, ma devono intendersi orientativi e ci riserviamo la facoltà di apportare varianti in qualunque momento.

sesino

HEAT EXCHANGING EXCELLENCE SINCE 1919

COSTANTE SESINO SPA: via Monza, 150 A/B 20060 GESSATE (MI)
info@sesino.com - www.sesino.com | tel. +39 02.95.38.03.34

