

# AP 830 EB

AC MOTOR AIR-OIL HEAT EXCHANGERS  
SCAMBIATORI ARIA-OLIO CON VENTILATORE A CORRENTE ALTERNATA

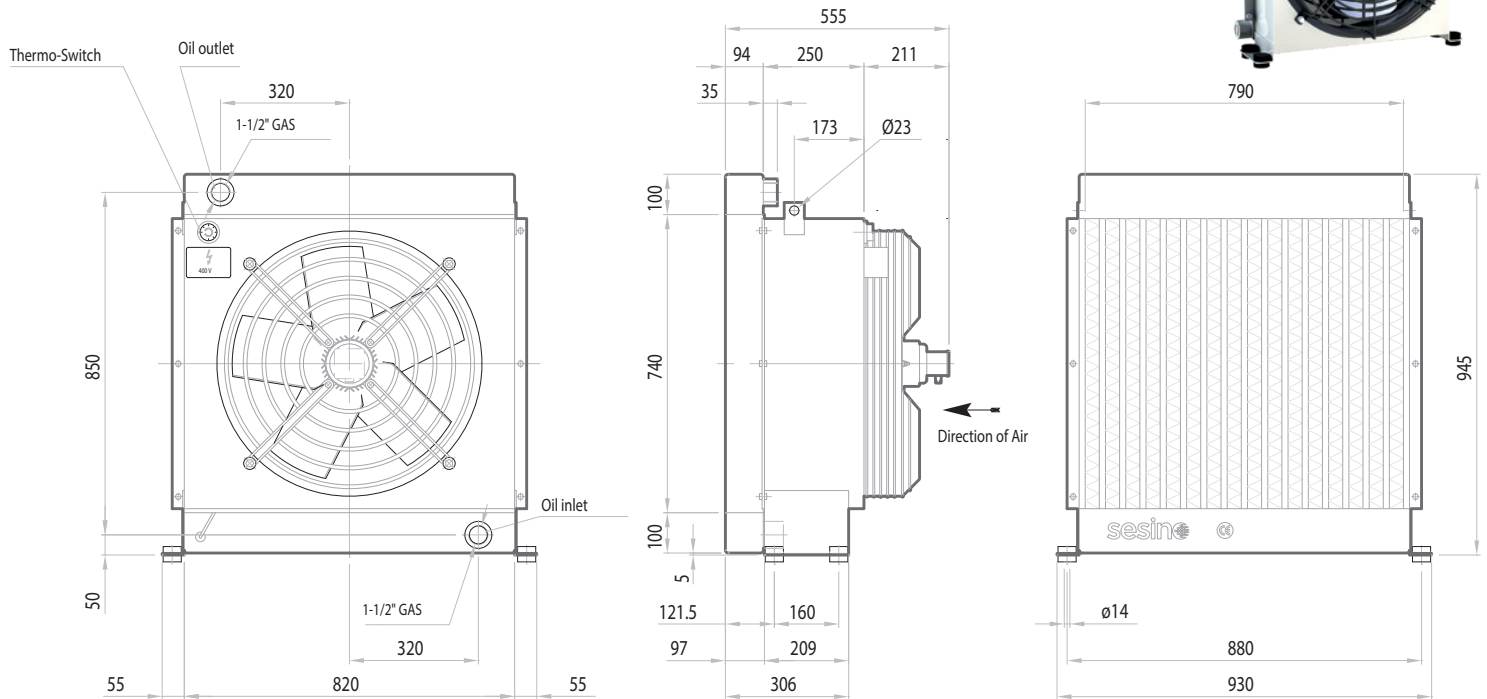

- Dimensions and technical characteristics are not binding



Static working pressure = 20 bar

Test pressure = 35 bar

OIL FLOW	CAPACITY	VOLTAGE	FREQUENCY	POWER	CURRENT	AIR FLOW	PROTECTION	NOISE LEVEL	WEIGHT	Ø FAN
l/min	l	V	hz	W	A	m <sup>3</sup> /h	IP	dB(A)	kg	mm
150-400	20	400	50	719	1,42	9.500	55	73	83	560
150-400	20	460	60	1132	1,81	11.500	55	75	83	560

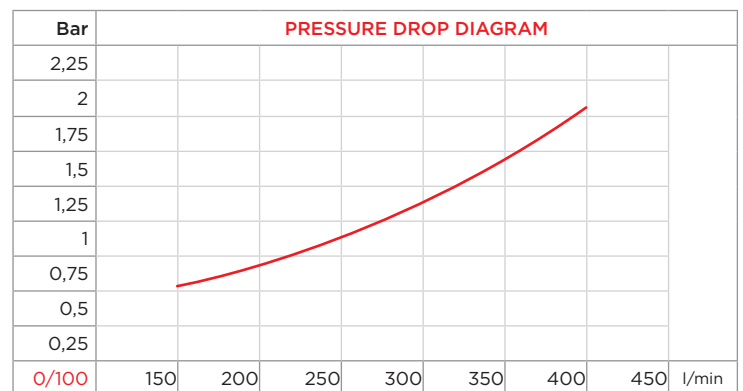
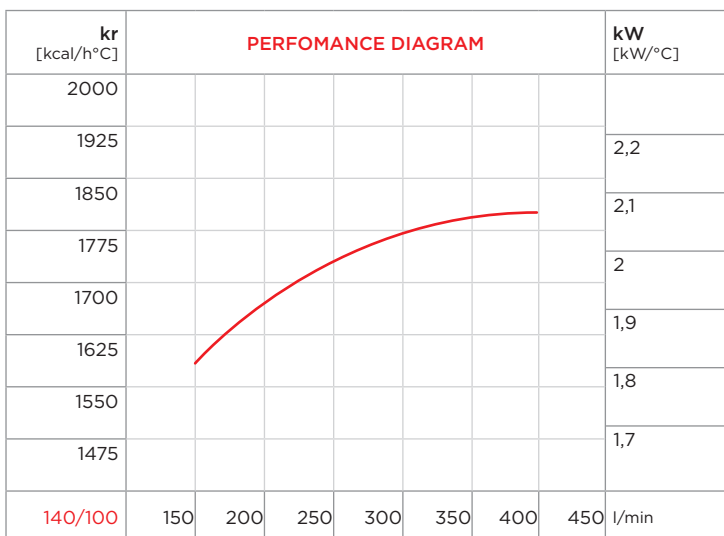

**CORRECTION FACTOR**

cSt	22	30	46	68	100	150	220
f	0,6	1	1,5	2,3	3,5	5	7

**PURCHASE CODES**

AP 830 EB three-phase	<b>3RAP830EB</b>
-----------------------	------------------

**SPARE PARTS**

Adjustable thermo-switch	1TRM0-90
Shock isolating mounting (4 pcs)	3KIT4232
Electric junction box for	1CSSDSAREL
Cooling element	3RNAP830E
Electric fan	1VNAP830DV
Frame	3CNAP830EB.1