

# AP 430/2 I

AIR-OIL HEAT EXCHANGERS WITH IDRAULIC MOTOR  
SCAMBIATORI ARIA-OLIO CON MOTORE IDRAULICO

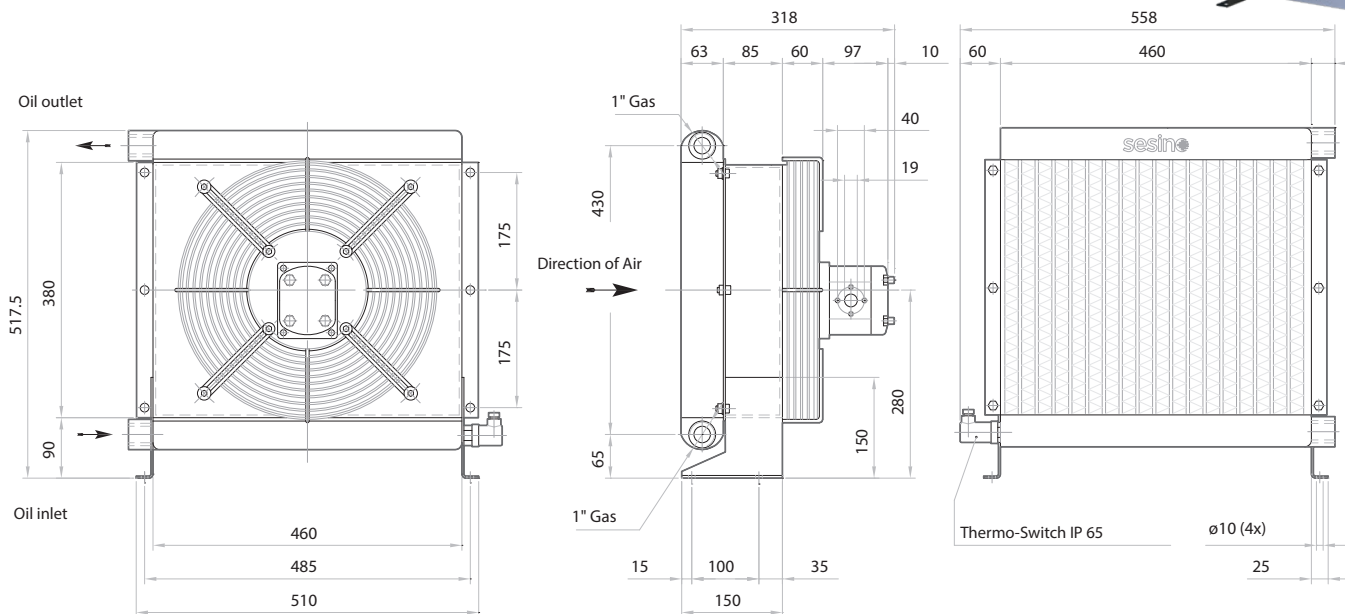

- Dimensions and technical characteristics are not binding



Static working pressure = 20 bar

Test pressure = 35 bar

OIL FLOW	FAN SPEED	POWER	DISPLACEMENT	MOTOR FLOW	AIR FLOW	NOISE LEVEL	WEIGHT	CAPACITY	Ø FAN
l/min	rpm	W	cc/r	l/min	m <sup>3</sup> /h	dB(A)	kg	lt.	mm
30-180	2.700	830	11,3	31	7.000	74	23	5,5	350

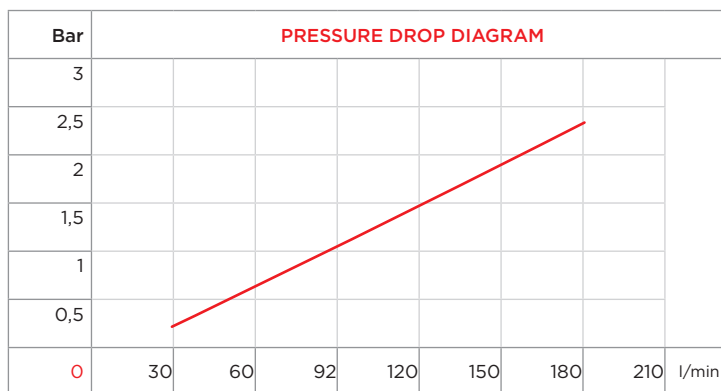
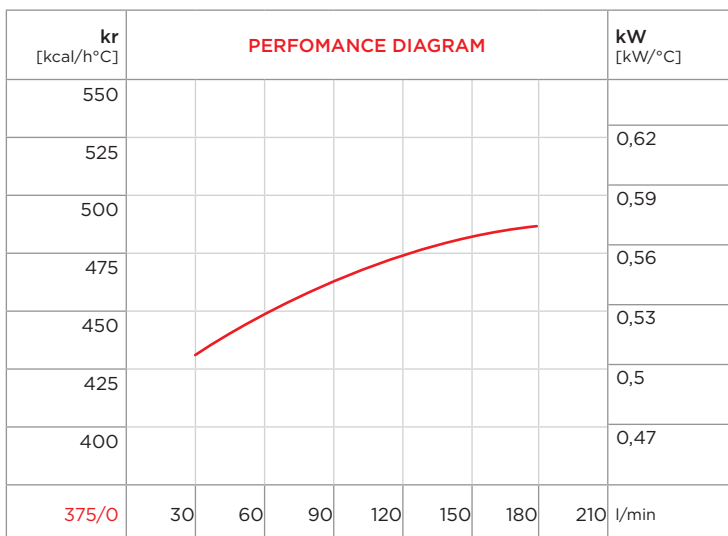

**CORRECTION FACTOR**

cSt	22	30	46	68	100	150	220
f	0,6	1	1,5	2,3	3,5	5	7

## PURCHASE CODES

AP 430/2 I with hydraulic motor	3RAP43211A
AP 430/2 I prepared	3RAP43214A

## SPARE PARTS

Cooling element	3RNAP432TP
Frame	3CN430I.1
Shock isolating mounting (4 pcs)	3KIT4511
Fan	1G3506345PAV
Fan grill	1RTAP430I
Hydraulic motor	1MO2/M16
Thermo-switch 60-49 IP 65	1TRM60-49
Thermo-switch 47-36 IP 65	1TRM47-36