

# AP 1200 EB

AC MOTOR AIR-OIL HEAT EXCHANGERS  
SCAMBIATORI ARIA-OLIO CON VENTILATORE A CORRENTE ALTERNATA

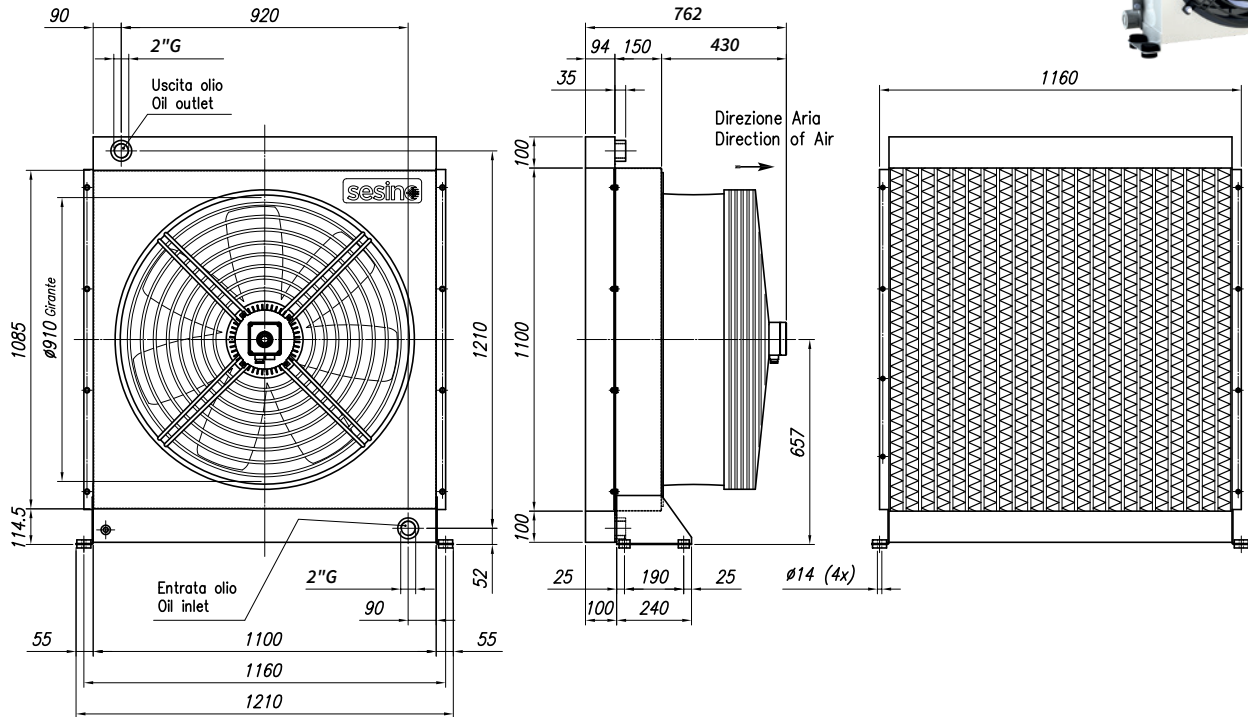

- Dimensions and technical characteristics are not binding



Static working pressure = 16 bar

Test pressure = 21 bar

OIL FLOW	CAPACITY	VOLTAGE	FREQUENCY	POWER	CURRENT	AIR FLOW	PROTECTION	NOISE LEVEL	WEIGHT	$\varnothing$ FAN
l/min	l	V	Hz	W	A	m <sup>3</sup> /h	IP	dB(A)	kg	mm
200-550	35	400	50	2250	4,56	25.000	55	80	135	910

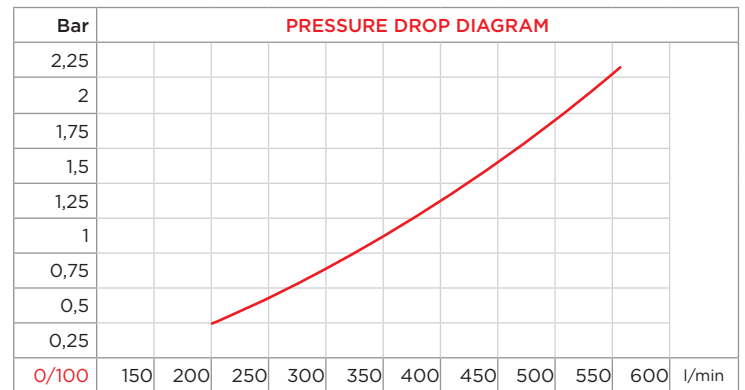
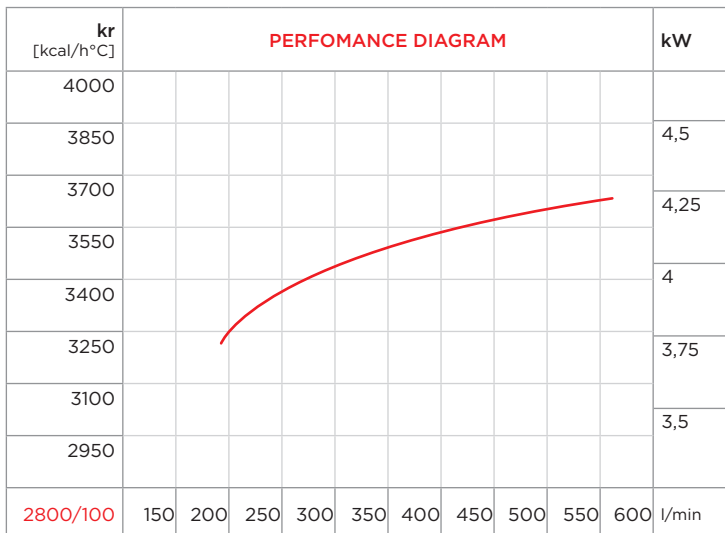

**CORRECTION FACTOR**

cSt	22	30	46	68	100	150	220
f	0,6	1	1,5	2,3	3,5	5	7

## PURCHASE CODES

AP 1200 EB three-phase	<b>3RAP1200EB</b>
------------------------	-------------------

## SPARE PARTS

Frame	3CNEO08586.1
Shock isolating mounting (4 pcs)	3KIT4232
Cooling element	1RO08423
Electric fan	1VNEO08586.3