

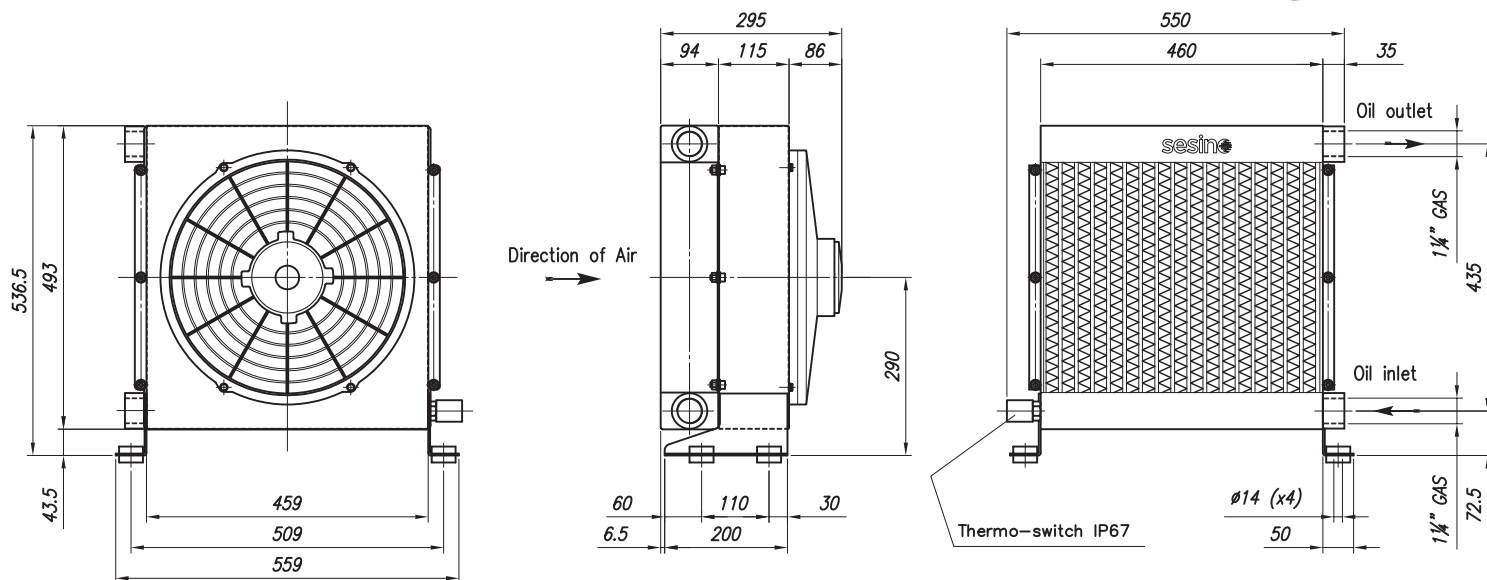

- Dimensions and technical characteristics are not binding



Static working pressure = 20 bar

Test pressure = 35 bar

OIL FLOW	VOLTAGE	POWER	CURRENT	AIR FLOW	ELECTRIC PROTECTION	NOISE LEV.	WEIGHT	CAPACITY	Ø FAN
l/min	V	W	A	m <sup>3</sup> /h	IP	dB(A)	kg	lt.	mm
30-240	12	240	20	2.800	68	85	25	8	380
30-240	24	240	10	2.800	68	85	25	8	380

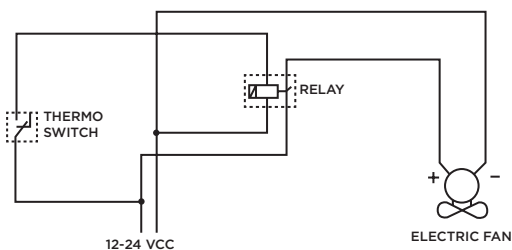
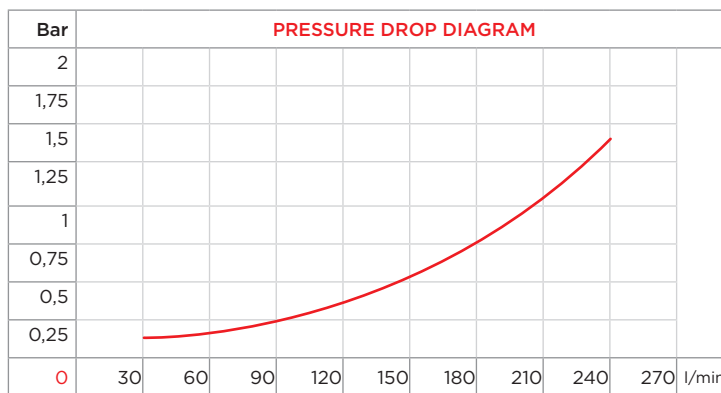
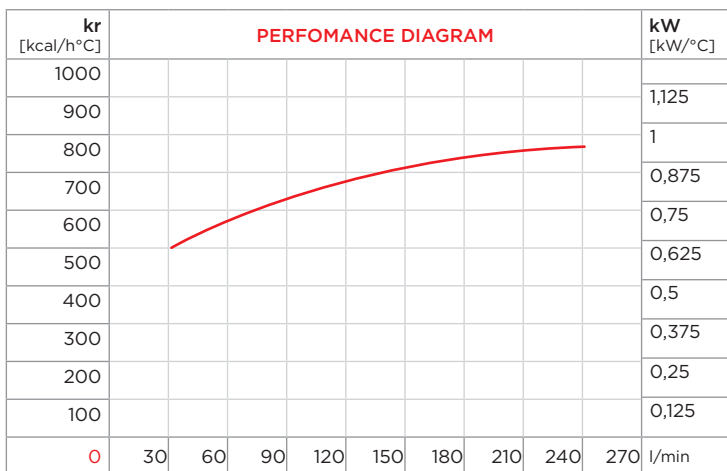

### PURCHASE CODES

APL 494 12/24V without thermo switch	3RL49412 / 3RL49424
APL 494 12/24V with thermo switch	3RL49412T247 / 3RL49424T247 3RL49412T260 / 3RL49424T260

### CORRECTION FACTOR

cSt	22	30	46	68	100	150	220
f	0,6	1	1,5	2,3	3,5	5	7

### SPARE PARTS

Thermo-switch 47-36 12V IP 67	1TRM47-36/12V
Thermo-switch 47-36 24V IP 67	1TRM47-36/24V
Thermo-switch 60-49 12V IP 67	1TRM60-49/12V
Thermo-switch 60-49 24V IP 67	1TRM60-49/24V
Cooling element	1RO99332
Frame	3CNL494.1
12VDC Electric fan	1MCVA18AP70AC
24VDC Electric fan	1VNAPL58024C