

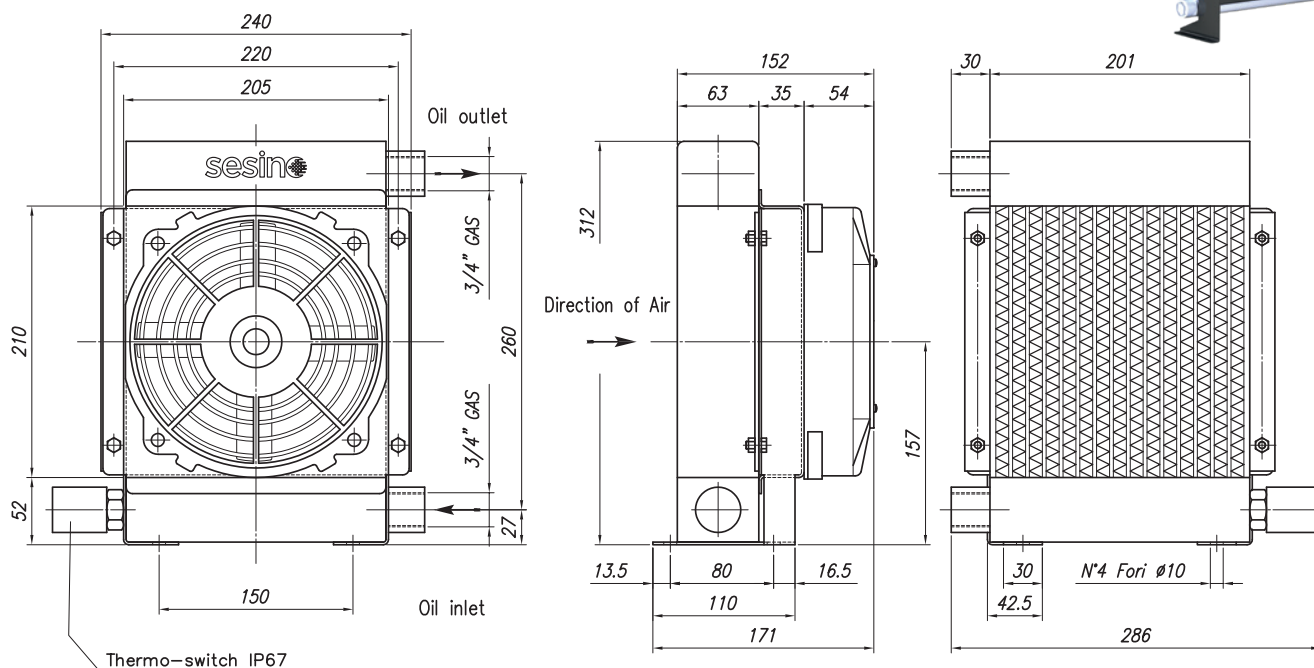

- Dimensions and technical characteristics are not binding



Static working pressure = 20 bar

Test pressure = 35 bar

OIL FLOW	VOLTAGE	POWER	CURRENT	AIR FLOW	ELECTRIC PROTECTION	NOISE LEV.	WEIGHT	CAPACITY	Ø FAN
l/min	V	W	A	m ³ /h	IP	dB(A)	kg	lt.	mm
10-80	12	65	5,2	500	64	72	5	1	190
10-80	24	65	2,6	500	64	72	5	1	190

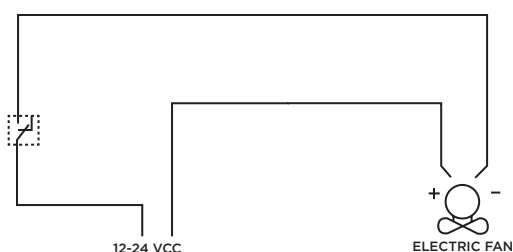
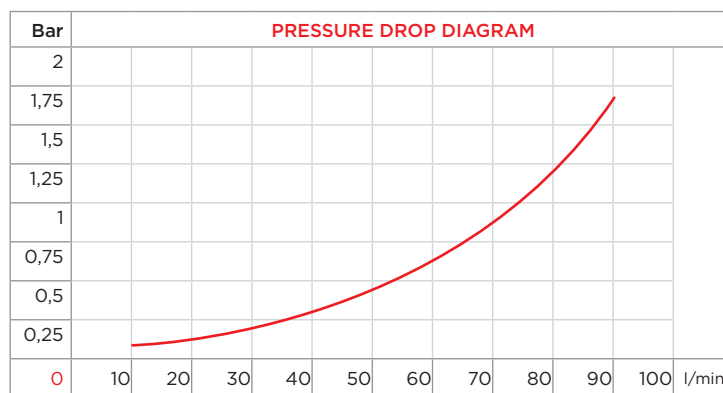
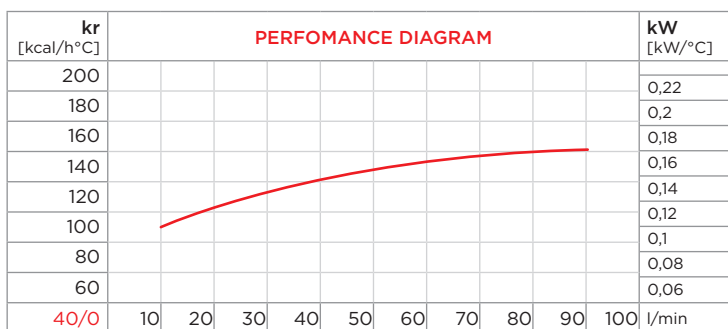

CORRECTION FACTOR							
cSt	22	30	46	68	100	150	220
f	0,6	1	1,5	2,3	3,5	5	7

PURCHASE CODES

APL 263 12/24V without thermo switch	3RL26312 / 3RL26324
APL 263 12/24V with thermo switch	3RL26312T247 / 3RL26324T247 3RL26312T260 / 3RL26324T260

SPARE PARTS

Thermo-switch 47-36 12V IP 67	1TRM47-36/12V
Thermo-switch 47-36 24V IP 67	1TRM47-36/24V
Thermo-switch 60-49 12V IP 67	1TRM60-49/12V
Thermo-switch 60-49 24V IP 67	1TRM60-49/24V
Cooling element	3RNL263
Frame	3CNAP260.1
12VDC Electric fan	1MCVA14AP7AC
24VDC Electric fan	1MCVA14BP7AC